

# RADIO BROADCAST

*Suspended  
with April, 1930*

WILLIS KINGSLEY WING . . . . . Editor  
HOWARD E. RHODES . . . . . Technical Editor  
EDGAR H. FELIX . . . . . Contributing Editor



VOL. XVI. NO. 6

ENGINEERING • THE LABORATORY • SERVICING

## Contents for April, 1930

Review - - - - -	W. K. W.	309
Industrial Changes	Problems	
The News Parade	Voice in the Wilderness	
Automobile Radio	The Pentode Again	
Licenses	New Models and a Trend	
Radio on Trains		
An Automatic Record Changer - - - -	Thomas E. Piazza	310
Book Review - - - - -	Edgar H. Felix	312
<i>Radio Law</i> by W. Jefferson Davis		
Measurements of High-Frequency Response -	Jesse Marsten	313
Tube Manufacturing Equipment in the Ken-Rad Factory, etc.		315
The March of Radio - - - - -	An Editorial Interpretation	316
Misleading Radio Advertising	The Coming of the Pentode	
Broadcasting Achievement	High Power in City Areas	
Characteristics of Television Signals - - -	C. H. W. Nason	318
Automobile Receiver Design - - - - -	Robert S. Kruse	320
High-Frequency Measuring Equipment - - -	H. D. Oakley	324
Measurements on Band-Pass Filter Circuits -	W. T. Coeking	326
The Investor Looks at Radio - - - - -	Berkeley A. Cater	329
Aircraft Radio Development - - - - -	Elmer L. Brown	330
Strays from the Laboratory - - - - -	Technical Shorts	333
Sun Spots and Radio	A Correction	
British Heater Tubes	Pentode Articles	
Measuring Percentage Modulation	Baron Manfred von Ardenne	334
Automatic Volume Control - - - - -	A. C. Matthews, Jr.	336
"Radio Broadcast's" Engineering Review Sheets - - - - -		337
Factors Governing Amplification	Calculating Amplification of Pentode Receivers	
Professionally Speaking - - - - -		339
1930 and Service	New Tubes	
The Serviceman's Corner - - - - -		340
Technique of Servicing	An SOS to Servicemen	
A Hum Filter	Two Simple Oscillators	
Servicing the Radiola	A Legal Question	
Data on Crosley Sets	More "Dope" on Noise	
"Radio Broadcast's" Set Data Sheets - - - - -		344, 346, 348
Bremer Tully Models S-81, S-82	Grebe Super-Synchrophase SK-4	
The Balkeit Model C	The Kennedy Chassis No. 10	
News of the Radio Industry - - - - -		350
Tube Makers Defend the Pentode	News of the Manufacturers	
Personal Notes	Matters Legal	
Recently Issued Patents	In the Tube Field	
	Remote-Control Patents	
In the Radio Marketplace - - - - -	Offerings of Manufacturers	354
Radio Broadcast Laboratory Information Sheets		
	Howard E. Rhodes	356, 358, 360
No. 337. Measuring Resistance	No. 341. Reflection of Sound	
No. 338. Types of Distortion	No. 342. Grid Current in Tubes	
No. 339. Detection Characteristics	No. 343. Speech Power and its Measurement	
No. 340. Calculating Detector Output	No. 344. Speech Power and its Measurement	

The contents of this magazine are indexed in *The Readers' Guide to Periodical Literature*, which is on file at all public libraries

## ... among other things

Elmer Brown, who writes in this issue about aircraft radio developments since 1929, has been with the RCA as an engineer, first at Van Cortlandt Park, New York, and now at Camden where he specializes in competitive receivers, special receivers and equipment. He has been with Magnavox, the U. S. Navy, and several West Coast distributors. Jesse Marsten admits that just thirteen years ago, he took his first commercial job in radio at the old Marconi plant at Aldene, N. J. "Thanks to the U. S. Navy and the Signal Corps," says Marsten, "enough work was provided to give us the experience that Mr. Wegeant, then the chief engineer, promised Carl Dreher and me as compensation for accepting \$10 a week. With the formation of the RCA out of the remains of the Marconi Company, I joined Dr. Goldsmith's research staff at C.C.N.Y. This staff was the nucleus of the RCA Technical and Test Department." For the past three years Mr. Marsten has been chief engineer of Freed-Eisemann. During the last eight years C. H. W. Nason has been with Federal Telephone and Chas. Freshman Companies in engineering work and has also done some consulting. He is at present developing television transmitter systems and audio-frequency amplifiers for Jenkins. His chief claim to fame is his operation of amateur station 3YK and that he was one of the last of the amateur fraternity to lay down the reactionary banner of "The Spark Forever." Thomas E. Piazza was born in Arequipa, Peru, and came to this country in 1926. He is intensely interested in development of mechanical devices and for the past eighteen months has been in the mechanical department of the Technidyne Corp.

The Balkeit Radio Company, of North Chicago, was never in bankruptcy we have been informed by R. L. Eglaston, now vice president of the company. It was incorrectly stated on page 251 of our March issue that Balkeit was involved in a bankruptcy action. This report reached us from a source which we believed to be correct and was printed in good faith. We greatly regret this occurrence and offer our sincere apologies to the Balkeit Company and its dealers. Set Data Sheet No. 36 in our January issue showing a Fada receiver indicated a 171A tube in the first a.f. stage whereas a 227 type is the tube actually employed.

For coming issues we can forecast, in addition to all our regular features, the following: an article by W. R. G. Baker, chief engineer of Radio-Victor, on engineering personnel problems; R. S. Kruse describes "R39," a new insulating material; H. D. Oakley, an attenuator for the signal generator; R. C. Hitchcock on design data for output transformers; Jesse Marsten on measurements of antenna-coupling systems in broadcast receivers; Baron von Ardenne on a system for measuring vacuum tube characteristics using the cathode-ray tube.

TERMS: \$4.00 a year; single copies 35 cents; All rights reserved. Copyright, 1930, in the United States, Newfoundland, Great Britain, Canada, and other countries by

## DOUBLEDAY, DORAN & COMPANY, INC., Garden City, New York

MAGAZINES . . . . .  
COUNTRY LIFE . . . . . WORLD'S WORK . . . . . THE AMERICAN HOME . . . . . RADIO BROADCAST . . . . . SHORT STORIES . . . . . LE PETIT JOURNAL . . . . . EL ECO . . . . . WEST BOOK SHOPS (Books of all Publishers) . . . . .

NEW YORK: <LORD & TAYLOR, JAMES MCCREERY & COMPANY, PENNSYLVANIA TERMINAL, 10 WALL STREET, GRAND CENTRAL TERMINAL, 51 EAST 44TH ST., 848 MADISON AVE., 105 EAST 57TH ST., 370 and 420 and 526 and 819 LEXINGTON AVENUE.> ATLANTIC CITY: <2807 BOARDWALK> CHICAGO: <75 EAST ADAMS ST.> ST. LOUIS: <310 N. 8TH ST. and 4914 MARYLAND AVE.> CLEVELAND: <HIGBEE COMPANY> SPRINGFIELD, MASS.: <MEEKINS, PACKARD & WHEAT.>

### OFFICES . . . . .

GARDEN CITY, N. Y. NEW YORK: 244 MADISON AVENUE. BOSTON: PARK SQUARE BUILDING. CHICAGO: PEOPLES GAS BUILDING. SANTA BARBARA, CAL. LONDON: WM. HEINEMANN, LTD. TORONTO: DOUBLEDAY, DORAN & GUNDEY, LTD.

### OFFICERS . . . . .

F. N. DOUBLEDAY, Chairman of the Board; NELSON DOUBLEDAY, President; GEORGE H. DORAN, Vice-President; RUSSELL DOUBLEDAY, Secretary; JOHN J. HESSIAN, Treasurer; LILLIAN A. COMSTOCK, Ass't Secretary; L. J. McNAUGHTON, Ass't Treasurer

# REVIEW

◆ **INDUSTRIAL CHANGES**—*Colonial* merges with *Valley Appliance*, of Rochester, combining, it is said, "the best features of each" from sales down through engineering. *Fulton Cutting* is chairman of the Board, *I. G. Maloff*, chief engineer, and *W. S. Symington*, president. *Magnavox* reorganized as a Delaware corporation to facilitate, it is darkly hinted, a merger. *Erla*, of Chicago, is said to be out of receivership; *Marti*, of East Orange, is reorganized and will sell sets direct to power companies in and near New York. *Temple*, of Chicago, was bought by a syndicate headed by *Leonard Welling*, formerly a New York Majestic distributor. *Bremer-Tully*, of Chicago, is discontinued as a sales organization and present *Bremer-Tully* sets are being unloaded.

◆ **THE NEWS PARADE**—President Hoover reappointed the entire Radio Commission, seemingly ignoring the strong opposition to some members which has developed, based on their record as radio administrators. All have been confirmed by the Senate. *Gen. Saltzman* was chosen chairman. Passage of a Communications Commission Act appears inevitable and this Commission would have radio as only one of its complex problems.

In the last year, said President *Richmond of RMA*, 25 per cent. of the radio manufacturers maintained price levels, 35 per cent. cut prices, and 40 per cent. were in financial difficulties. This statement, made before the Cleveland Convention of the N. F. R. A., was not received kindly by the attending luminaries who felt that such public frankness was not politic.

◆ **AUTOMOBILE RADIO**—*Michael Ert*, retiring president of N.F.R.A., told members of his association that the installation of radio receivers in automobiles offered great profit possibilities to the radio industry in the coming years. . . . *New Hampshire State Commissioner of Motor Vehicles Griffin* says: "New Hampshire is against automobiles equipped with radio which can be operated while the car is in motion. This department is satisfied that the greater percentage of accidents is due to inattention of drivers, and where a radio is being operated while the car is in motion it certainly would tend to divert the attention of the operator". . . . Sales and service of the *Delco* automobile radio, made by *General Motors*, will be handled

SOME OF THE events in the world of radio in recent weeks may have escaped you. A few of the more important, to our way of thinking, are presented on this page.

by *United Motors Service* which has 3000 authorized service stations and 27 "control branches" in the United States . . . *Willard Battery* service stations will install and service *Transitone* automobile radios.

◆ **LICENSES: MORE AND LESS.**—Two tube manufacturers signed R.C.A. licenses, *Cable* and *Perryman*. Fourteen tube makers now hold an R.C.A. license. *DeForest* and *Arcturus* are not licensed. . . . On January 1, the R.C.A. licenses of *Walbert*, of Chicago, were cancelled. Shortly after, however, tuned-radio-frequency and electric-phonograph licenses were granted by R.C.A. to the *Story & Clark Radio Corporation*, of Chicago, and to the *Transformer Corporation of America*, Chicago.

◆ **RADIO ON TRAINS**—Radio installations on important trains continue. *Stromberg-Carlson's* automatic-volume-control model has been supplied to Chicago, Burlington and Quincy for three new trains added by the C. B. & Q.

◆ **PROBLEMS**—On every hand, those who struggle with radio problems refer decisively to the automobile industry as a perfect example of a well-managed industry. Says *Norman G. Shidle*, directing editor of *Automotive Industries*: "The most vital questions in the minds of factory executives now seem to relate to dealer relations in one way or another. Some of the questions getting most attention are:

1. Gearing car output to dealer and consumer demands.
2. Dealer discounts.
3. Service policies, particularly as to whether factory or dealer shall pay labor charges on parts replaced during the standard warranty period.
4. Junking plans.
5. To reimburse or not to reimburse dealers for any of losses on cars in stock at time new model is announced.
6. To reimburse or not to reimburse dealers for losses on cars in stock when a price-cut is made.
7. Possibilities of non-cancellable contracts.
8. Closed territories.

Write your own comment.

◆ **VOICE IN THE WILDERNESS**—Out of the millions of good and earnest words expended at the Cleveland convention of the National Federation of Radio Associations came a resolution to enlist the Association actively in the case of better broadcasting. Says the resolution, in part: ". . . Good broadcasting is the foundation of the radio industry and should have our support on all situations arising that affect it,

"Be It Therefore Resolved, that a standing committee be appointed . . . for the purpose of cooperating with the National Association of Broadcasters and to be ready to make recommendations to this association at any time."

Dealer discounts, tube policies, or exclusive wholesale territories don't matter much if the radio listeners don't listen.

◆ **THE PENTODE AGAIN**—News from the trademark division, U. S. Patent Office: application "Ser. No. 293,289. Radio Corp. of America, New York, N. Y., filed December 5, 1929. Trade Mark: 'Pentode' for electrical vacuum tubes and valves. Claims use since November 25, 1929." . . . R.M.A. engineering division argues that the pentode will not permit any accomplishments not possible with present tubes. For "pentode" read "screen-grid tube." How well the argument fits set designs of the season just closed! . . . The industry discussion raging around the pentode may have the effect of bringing holders of opposing points of view to the conference table. Several such meetings have already been held and further discussions between tube and set makers are in prospect. Conferences before the fact are rare in radio business where the practice has been to wait until the die is cast. . . . Says *Oscar Getz*, of *Steinitz*: ". . . I feel that it is time that the radio manufacturers should take a hand in the control of their own destinies."

◆ **NEW MODELS AND A TREND**—Since we last met, in the phrase of *Nation's Business*, *United Reproducers* has announced a new model, K-70, to sell at \$149.50, less tubes. *U. S. Radio & Television* announced the *Apex* seven-tube set complete with tubes at \$101.00, and *Sparton*, Model 589 to sell at \$159.85 complete with tubes. If two manufacturers of radio receivers offer models this early in the season priced with tubes, is it a Trend? Our answer is a slightly hesitating "Yes."

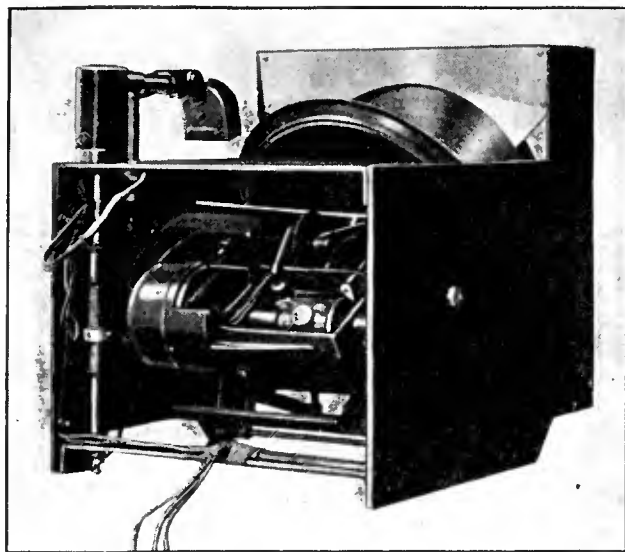

# AN AUTOMATIC RECORD CHANGER

By **THOMAS E. PIAZZE**  
*Technidyne Corporation*

THE WIDESPREAD use of radio during the last seven years for entertainment purposes in the home has created a new appreciative audience for music. At the same time experience has developed certain limitations in the use of radio which prove annoying to those in whom the desire for such musical entertainment has already been developed.

In communities a hundred miles or more from broadcasting stations, where the signals are relatively weak, there oftentimes develops considerable disturbing noise due to power line leaks, electric railways, and miscellaneous electrical industrial apparatus. It is unfortunate that these noises tend to become most pronounced in damp or wet weather due to electrical leakage over insulators or between power lines and trees or other foliage through which they pass, as it is just during such weather that most people desire to stay at home and be entertained by their radio.

The last seven years experience with radio broadcasting has also demonstrated that there are some sections in the United States where, for periods of from one to six months during the year, radio reception conditions are unfavorable due to normal static disturbances from electric storms. In such regions, and especially in sections remote from the more powerful broadcasting stations, a demand has grown up for musical entertainment to supplement the radio in the home, indicated by a growing proportion of sales of radios equipped with phonographs.

## *New Interest In Phonograph*

Radio broadcasting from its first appearance proved a tremendous novelty. People were very enthusiastic over the variety of up-to-date music and information that radio could supply for the home. These features proved powerful enough to cause everyone to overlook almost entirely the importance of the phonograph. However, the improvement in tone quality resulting from tying up the phonograph with the radio set, together with a certain novelty value in the combination, has already created a new interest in the phonograph.

Sales of the new electrically recorded records have been increasing rapidly and it is thought that this results not only from the superior tone quality and relative convenience of the electric phonograph, but also from a strongly stimulated desire for some pieces of music frequently heard over the radio, or else brought to mind from long ago.

We believe that a more rapid growth of phonograph use will naturally follow now from the introduction of any device tending to make the operation of the phono-

graph easier and more convenient. There is no doubt but that the quality of music obtainable from good electrically recorded records reproducing through the modern magnetic pick-up unit and audio amplifying system with a quality loud speaker, as used in broadcast radio sets, is as good if not better than that which may be secured from the average radio broadcast program. Certainly when receiving conditions are bad the absence of noise tends to make phonograph reproduction a favorite.

## *Simplified Operation*

Any device tending to reduce the attention necessary for phonograph operation tends to increase the enjoyment to be had from a phonograph program. Such things as electric-turnstile operation, eliminating the necessity of rewinding; or the use of special needle points which need only to be changed every fifty or hundred records go part way towards easing phonograph operation.

Many sales people experienced in the phonograph field believe that the greatest obstacle to the more widespread use of the phonograph is the necessity for getting up every three or four minutes to change the record. A recent attempt has been made to minimize this annoyance by building an electric turntable into a small end-table so that the record change may often be arranged near at hand. This involves the separation of the playing

instrument into two parts connected by electric cables and is not always convenient. Neither does it fully avoid frequent attention to the phonograph.

This undoubtedly suggests, why has not the automatic record changer come more into use? We asked a sales representative of one large phonograph company not marketing an automatic record changer why his company did not have one. The answer is instructive. He said, "So far, using an automatic phonograph has been like going out for a ride in a poor automobile; you might as well walk." This represents the nub of the question. No small-sized record changer so far has proved reliable for home use. We would add also that probably little sustained effort has been exerted to create an automatic record changer which is simple, fool-proof, and capable of handling the variety of records, even of one nominal size, to be found on the market. Possibly those charged with such development were especially interested in creating a machine which would handle the records manufactured by their own company and were not much concerned with what would happen if records of other manufacture were inserted.

## *Record Changing*

Realizing some years ago that the stimulation of an active demand for automatic record-changing phonographs would be relatively easy with an instrument which

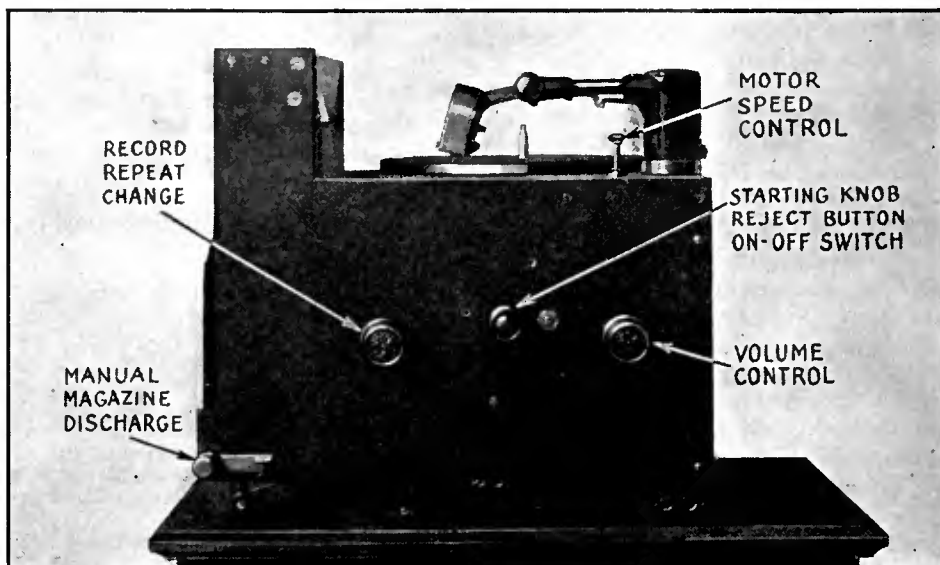

*The important parts of the Technidyne automatic record changer are identified in this close-up view of the instrument.*

*A Description of a Simple Mechanism Handling all Types of Phonograph Records in Which the Time Between Selections Has Been Reduced to Ten Seconds. Developed in the Technidyne Laboratories.*

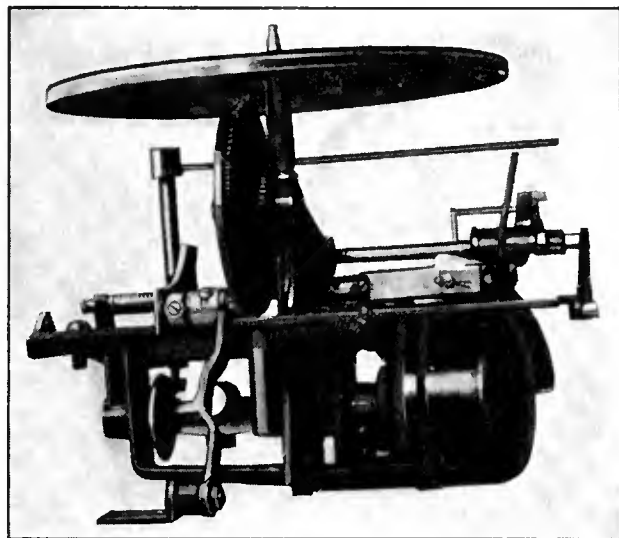

was at once universal, compact, economical, and fool-proof, the Technidyne Corporation set about the development of an ideal automatic record changer. This has been achieved and demonstrations have recently been made for leading manufacturers. A description of this machine showing the principle of its operation follows:

The record changer is shown assembled in the pictures on page 310 and the motor unit with turntable is shown at the top of this page.

The record is picked up and discharged by the turntable rotating bodily with the motor. Fig. 1 to 7 help in explaining the operation. Fig. 2 shows the records stored in a magazine ready to be played with the turntable in its normal position. Fig. 3 shows the turntable rotated through 90° and a record ejected from the storage magazine and resting against the turntable. Fig. 4 and 5 indicate the turntable rising and picking up the record.

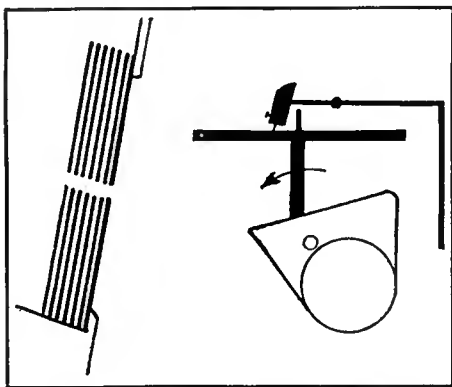

*Fig. 2—Step one: records stored in magazine and turntable in its normal position.*

In Fig. 4 it will be noted that the center pin on the turntable is pushing against the record and Fig. 5 shows the record falling back against the turntable with the center pin in the hole of the record.

Fig. 6 shows the record in the normal playing position with the pick-up resting on it.

Fig. 7 shows the turntable tilted through 90° with the push-rods pushing the record off the centering pin so that it can drop into the discard magazine below.

Figs. 5 and 6 indicate how the record rises underneath the pick-up thus eliminating the necessity of any mechanism for raising or lowering the pick-up unit.

*How It Works*

In Fig. 1 there is shown a record magazine, A, a motor and turntable, B, and a

tone arm C. The magazine A has a capacity of about twenty records and is loaded through a slot in the front of the cabinet. The machine is started from the position shown in Fig. 2 by a push-button control. The first operation of the machine is when the empty turntable tilts over through an angle of 90° at which point a

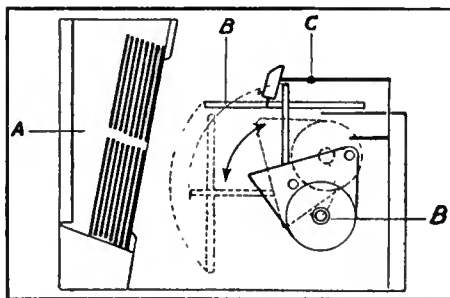

*Fig. 1—Schematic drawing of the record changer. A, record storage magazine; B, motor and turntable; C, tone arm.*

record is ejected from the magazine, A, and falls on fingers, D, with the upper part of the record resting on the edge of the turntable as shown in Fig. 3. The turntable rotates back to its normal playing position. During this motion the centering pin slides up the record below the center hole, bearing against the record as shown in Fig. 4.

As the turntable continues to rise to its normal position the pin engages the hole in the record as shown in Fig. 5. During the remainder of the motion towards the playing position the record is carried on the pin and finally deposited on the turntable, as in Fig. 6. After a record has

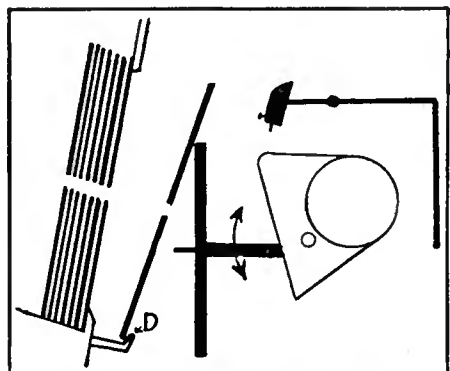

*Fig. 3—Step two: turntable rotated 90 degrees and record ejected from magazine.*

been played, an automatic control operates to engage a one-revolution clutch, starting the tilting operation. The turntable moves down with the record and at a certain angle the discharging fingers E disengage the record from the pin, and the record falls down to a discard magazine as shown in Fig. 7.

*All Records Accepted*

Any record may be played over one or more times by turning a change-repeat knob. This disconnects the mechanism of the record-storage magazine from the tilting motor so that no records are ejected for pick-up. It also disconnects the arms pushing the record off the center pin so that the record to be repeated stays on the table.

The tone arm and pick-up unit are quite free of mechanism. The pick-up is raised by the record rising underneath it as the table comes back to the horizontal posi-

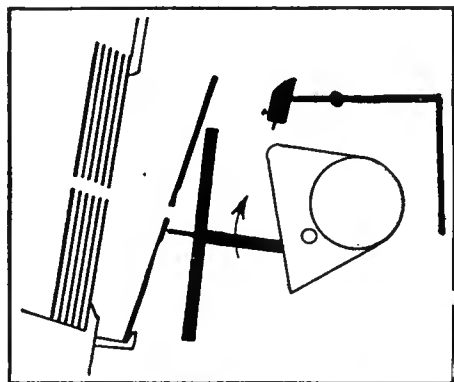

*Fig. 4—Step three: turntable rising to pick up record ejected from magazine.*

tion. This action is relatively gentle even though the entire cycle occupies only 10 seconds. This is because this part of the cycle corresponds to the crank (which tilts the table) operating in the region near dead center.

The pick-up unit is pushed inwardly by a light spring up to a stop so that the needle contacts with the outer edge of the record as the record rises, then the spring lifts the pick-up clear of the stop. This outer edge is a blank margin, but the pick-up is impelled slowly inwards towards the first sound groove by a small radial component of record motion under the needle, secured by placing the tone arm center slightly inside the tangent to the record circumference at the needle. This arrangement forms a simple way of



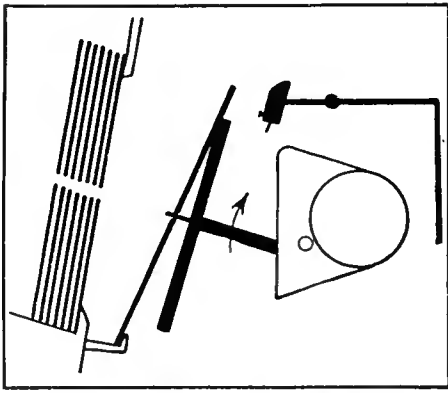

Fig. 5—Step four: turntable picks up record with center pin while returning to position.

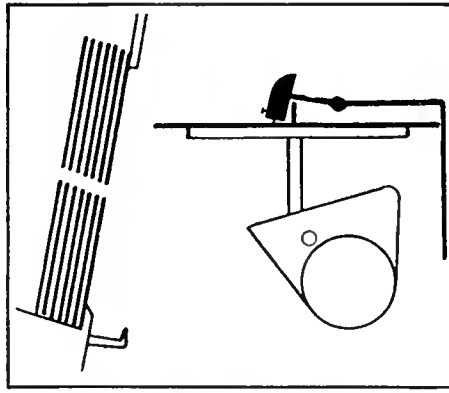

Fig. 6—Step five: turntable, phonograph record, and tone arm in normal playing position.

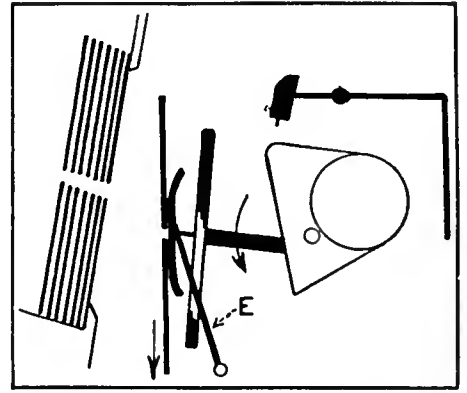

Fig. 7—Step six: turntable is tilted to reject record in the discard magazine.

insuring the playing of all records at their beginning and without loss of time.

#### Automatic Control

The device for initiating the record change when a record has been completed is of prime importance. It must be quick, unerring and unerring. Since various makes of records have different terminating grooves, all at different internal diameters, a quite universal device is required. The problem is complicated by the small motions, accelerations and the great diversity of normal sound groove spacings.

#### The Trigger Release

The Technidyne automatic control is a simple solution for this problem which is based on new mechanical principles. One of these new principles is that a smooth shaft will slip through a fairly tight bearing at a certain low axial speed very easily when the shaft is rotating but great resistance is offered for higher axial speeds.

A trigger release is held stopped on a smooth rotating shaft by a pin held balanced in unstable equilibrium on an arm rotating with the tone arm. When the tone arm either stops moving or accelerates at the end of a record this pin falls off and permits the trigger release to rotate with the shaft and start the tilting cycle. The pin falls off in a half second

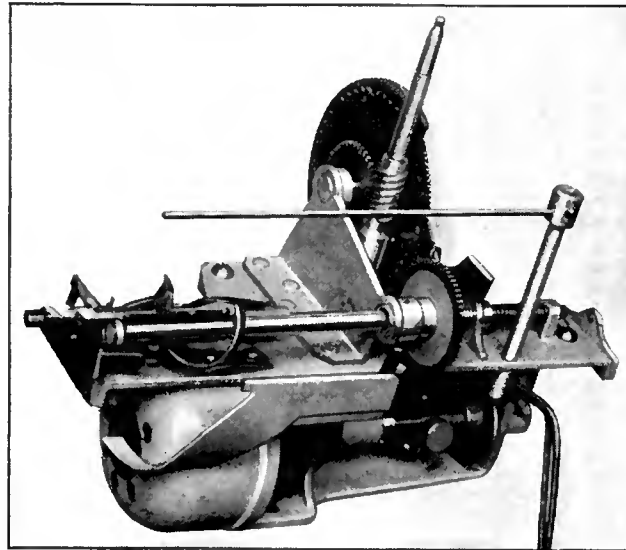

Close-up view of tilting motor.

when the needle enters a special terminating groove, and in about 6 seconds when the tone arm stops due to the needle entering the last closed groove of a record with no special terminating groove.

The development of the Technidyne automatic record changer was guided by the desire to secure a machine which, besides being simple in construction and operation, would be able to handle the great number of different makes of records now on the market. Records of one nominal

size, say ten-inch records, vary in thickness and diameter as between different manufacturers. Records will oftentimes become slightly warped due to their being stored edgewise in too hot a location, as, for example, next to a radiator. Great flexibility and reliability in handling such records has been secured in the Technidyne device by a full utilization of the principle of three-point suspension. In the record-storage magazine the record is first supported at one point below and two points above. During the operation of loading on the turntable the record is supported at two points below and one point above, the upper point being the center pin of the turntable. Large variations in record diameter and thickness are permissible because the record remains in leaning engagement with the center pin of the turntable as the table rises. The pin must slide by the center hole of the record at some time, and then the record must be picked up by the turntable and placed in position.

While there are undoubtedly many other good ways of mechanically performing the record changing operations we are confident that many records will be automatically changed the Technidyne way before inventive genius develops another system providing the easy and natural sequence of motions resulting from the use of the system herein described.



## BOOK REVIEWS



RADIO LAW. By W. Jefferson Davis. Published by Parker, Stone & Baird Co., Los Angeles, Cal. 364 pages.

The recent work *Radio Law* by W. Jefferson Davis is not to be confused with *The Law of Radio* by Stephen C. Davis. The new volume analyzes the influence of many recent decisions which define the powers of the Federal Radio Commission and the rights of broadcasting stations.

Its author is a member of the Air Law Committee of the American Bar Association and, on the very first page, generously disposes full credit for the passage of the Radio Act of 1927 exclusively to that organization. This is indeed a fine tribute to the months of work performed by the Radio Coördinating Committee appointed by L. B. F. Raycroft and usually considered responsible for the acceptance of the compromise act finally adopted.

The book is obviously that of a lawyer

writing about radio and not a radio man writing about law. For example, he states: "Radio began as a curiosity, became the obsession of small boys, progressed to the stage of a popular amusement, and then suddenly flowered into the most overwhelming industry in the history of communications." Actually, radio has been a recognized method of communication for three decades and had a commercial communication history of twenty years before broadcasting became "a popular amusement."

However, these are small objections to a book which presents not only such a comprehensive history of radio regulation in the United States but a brief summary of its progress in Europe. The Radio Act is, of course, analyzed and supported by interpretations of the Commission's legal department on various sections. State and municipal regulations of reception and transmission; important copy-

right decisions; a comprehensive study of the work of the Washington Radio Conference of November, 1927, with the lengthy convention quoted in full; rules for hearings before the Commission; legislative defects in the prescribed procedure; the character and effect of General Order 40; and the problems of radio legislation as analyzed by the American Bar Association's Committee on Radio Law, are some of the subjects adequately covered in the volume. The index is particularly complete, making the volume a handy reference for lawyers handling radio cases.

A reading of the book makes obvious the fact that the most important decisions controlling the future operation of powers of the Federal Radio Commission are yet to be made and that amazingly slow progress has been made in defining the position and powers of the Commission during its three years of operation.

—Edgar H. Felix.

# MEASUREMENTS OF HIGH-FREQUENCY RESPONSE

By **JESSE MARSTEN**  
*Chief Engineer, Earl Radio Corporation*

*Sideband Suppression as a Function of the Characteristics of the R.F. Amplifier, Detector Circuit, and Audio-Frequency Amplifier. Discussion is Based on Measurements of a Number of Modern Commercial Receivers.*

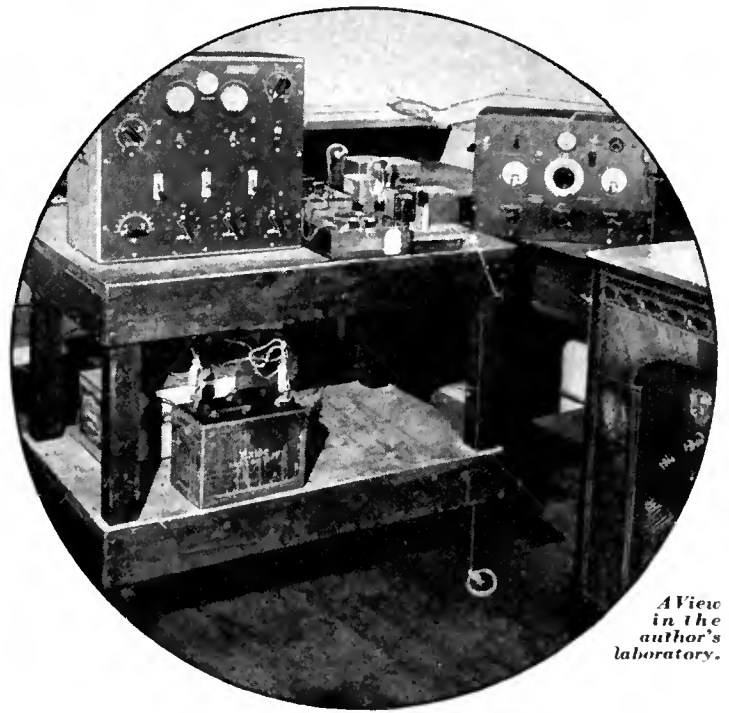

*A View in the author's laboratory.*

HIGH-QUALITY REPRODUCTION of sound presupposes an overall fidelity curve which is flat, or reasonably so, from 60 to at least 5000 cycles. There are two methods, generally speaking, of arriving at this objective. One is to design the component parts of the entire system so that they all have the desired flat characteristic. The other is to design the component parts so that one compensates the deficiencies of the other. The tendency among designers is generally towards the former.

While very notable gains have been made towards a realization of this goal, an examination of the fidelity curves of representative radio sets reveals that, so far as the receiver chassis is concerned, the rhapsodies of our advertising brethren are hardly justified. "True," "Lifelike," "Realistic," "Natural,"—that is what we would like the sound reproduction from our radio sets to be. We have a long way to go before such adjectives will be warranted.

## Engineering Problems

There have been and still are numerous factors which have militated against securing the best grade of sound reproduction from radio sets, and our engineering compromises are simply concessions to

these factors. These are gradually being overcome with resultant improvement in quality, and the point has been reached where the most important failing is the lack of high frequencies. It may be worth while to review very cursorily the changing trends in audio-frequency reproduction over the past few years.

The early battery receivers had audio-frequency amplifiers which were woefully lacking in low frequencies, and high frequencies above 2000 or 3000 cycles. These deficiencies, unfortunately, were further accentuated by the horn-type loud speaker, then in vogue, which had similar failings. The result was "tinny" quality. The transition to the balanced-armature-driven cone loud speaker gave considerable improvement in low-frequency response, and also extended the high range somewhat. Bigger and better audio-frequency transformers appeared on the scene, and the advent of the low-impedance output tube of the 171 type improved matters still further.

By this time, just before the introduction of the a.c. tubes, high-gain, shielded, radio-frequency amplifiers were well developed, employing three and four stages of amplification. For weak signals the noise level in such high-gain receivers was

too great, and in order to reduce tube hiss and atmospheric muck, the higher audio frequencies were deliberately suppressed, either by the use of high-frequency filters or otherwise doctoring the audio-frequency system—a typical case of compromise mentioned above. This loss in high-frequency response was accentuated somewhat further by sideband suppression in the r.f. amplifier.

## The A. C. Tube Enters

With the introduction of a.c. tubes a further loss in the range of audio-frequency reproduction was temporarily encountered, this time at the low-frequency end. The object, of course, was reduction of hum. However, the use of the 227-type tube and improvement in filter systems, remedied this condition, and the almost universal adoption of the electrodynamic loud speaker resulted in quite satisfactory low-frequency performance. The console type of cabinet had also arrived. By this time the dear public had learned what it wanted in the way of tone. The cry arose for "mellow tone." Frequencies above 2000 or 3000 cycles were not wanted. Loud speakers were even sold with filters in them to cut out everything over 2000 cycles, should the receiver hap-

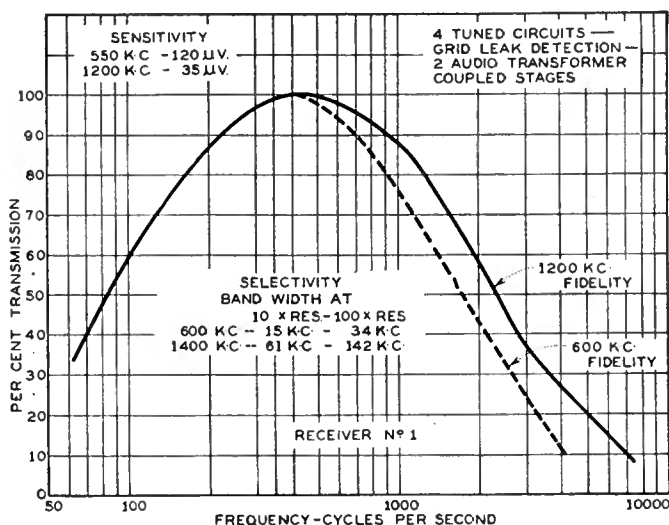

Fig. 1

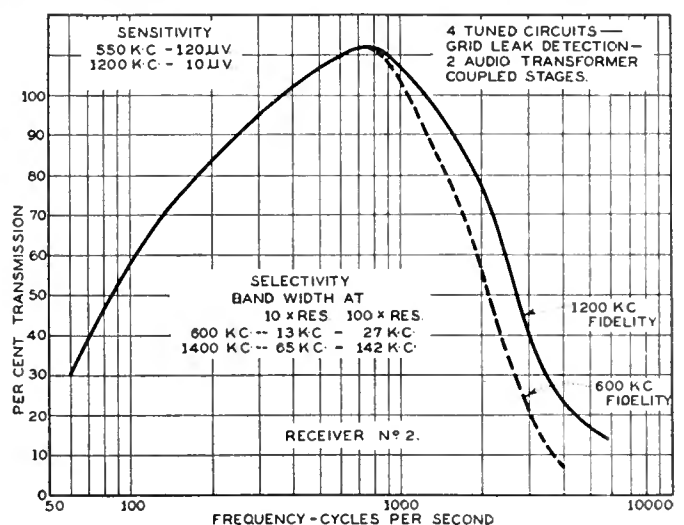

Fig. 2

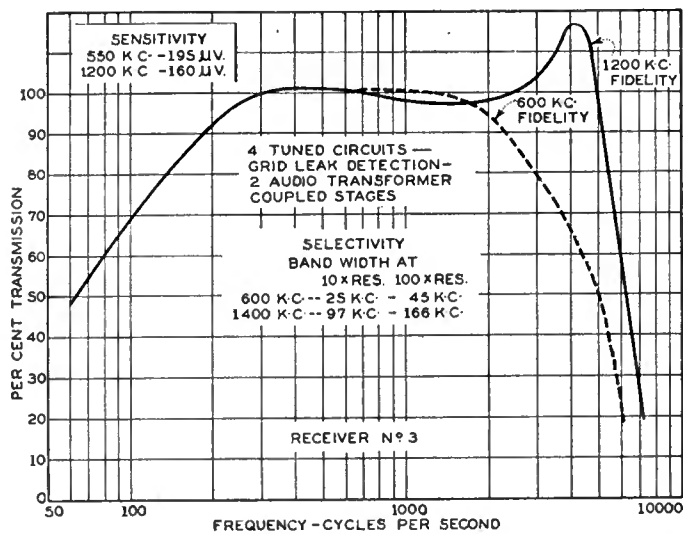

Fig. 3

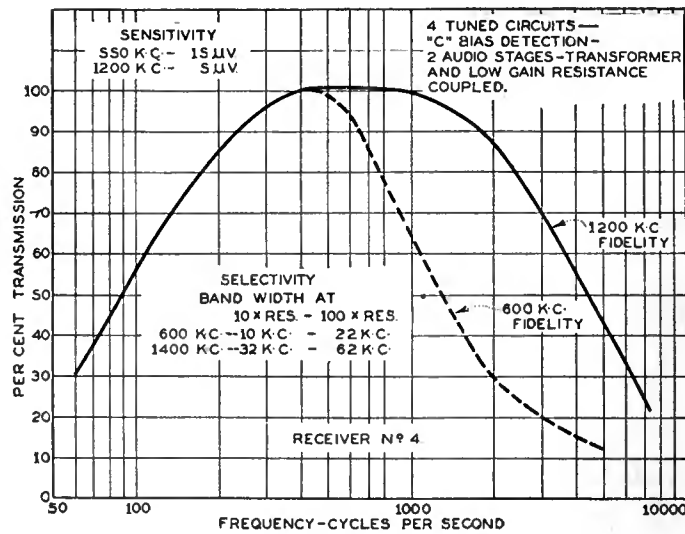

Fig. 4

pen to pass these frequencies. The public got what it wanted in an avalanche of "boom-boom." Low frequencies, loud speakers resonant at low frequencies, and cabinet resonance, all contributed to the "mellow tone" which was accentuated by lack of appreciable highs.

After a year or so of the "mellow tone" there were signs of a turn about. This meant high frequencies. Much was said about high-frequency loss in the grid-leak detector system. Band-pass filter systems were advocated to eliminate sideband suppression in the radio-frequency amplifier. Then came the a.c. screen-grid tube and with it predictions of greatly improved tone quality. The advertisements proclaimed it widely. We were to have a new era in tone quality.

### Improved Design

There followed, indeed, very major improvements in receiver design, but they did not appear in the fidelity curves. High-gain radio-frequency amplifiers permitted the use of the "high-level" C-bias detector and one audio-frequency stage. The elimination of the grid leak and condenser was to improve high-frequency response. The use of a low-gain audio-frequency amplifier (one a.f. stage, or two

a.f. stages one of which was a low-gain, resistance-coupled stage) would better low-frequency response and also improve high-frequency response. However, no such improvement, in general, was ob-

good down to 60 cycles. But, except in one case, the high-frequency a.f. performance is noticeably poor.

The fidelity curves given here have been plotted using as ordinates "Percentage Transmission," 400 cycles being the reference frequency. This unit has been chosen in preference to the decibel because it shows up deficiencies much more conspicuously. A really poor fidelity curve doesn't look half bad on paper when plotted in decibel units. It may be assumed that the frequency characteristic curve of the audio-frequency amplifier in any receiver coincides with the fidelity curve of the receiver at 1200 kc. since in all receivers examined sideband suppression at this frequency plays practically no part. All fidelity curves were taken the same way with output resistance loads appropriate to the output tubes used. The method employed is that described in the suggested I. R. E. standards. Information relative to sensitivity and selectivity of each receiver is contained on each curve sheet. The sensitivity is expressed in microvolts input required to give 50 milliwatts output. The selectivity, in accordance with accepted practice, is expressed as the resonance band width in

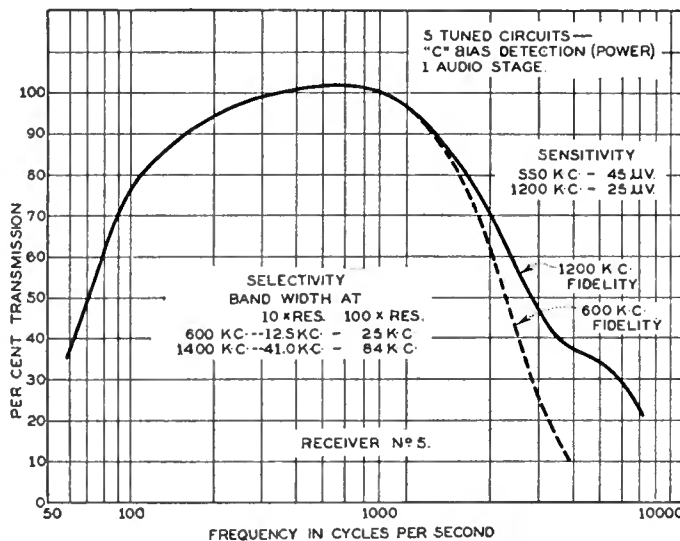

Fig. 5

served in a number of receivers examined, especially as regards the high-frequency response. The low-frequency response, in general, was satisfactory especially down to 100 cycles. In some cases it was

in microvolts input required to give 50 milliwatts output. The selectivity, in accordance with accepted practice, is expressed as the resonance band width in

(Continued on page 347)

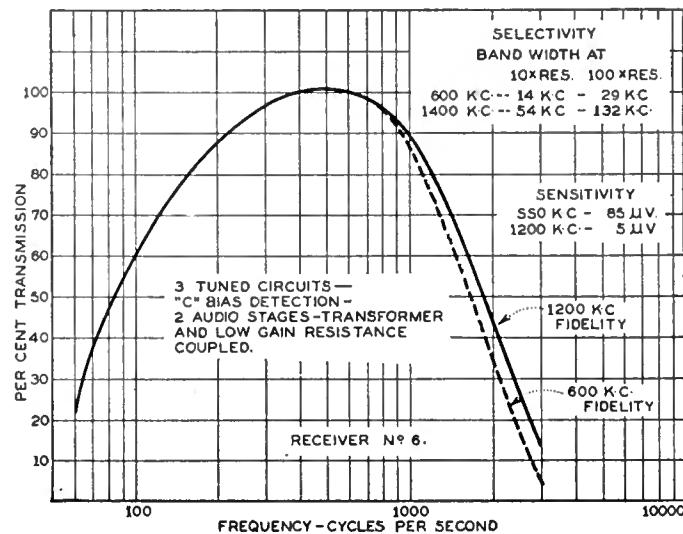

Fig. 6

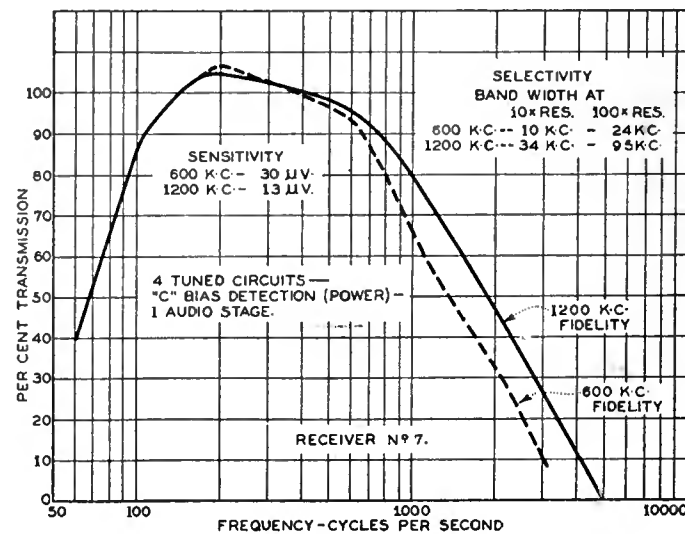
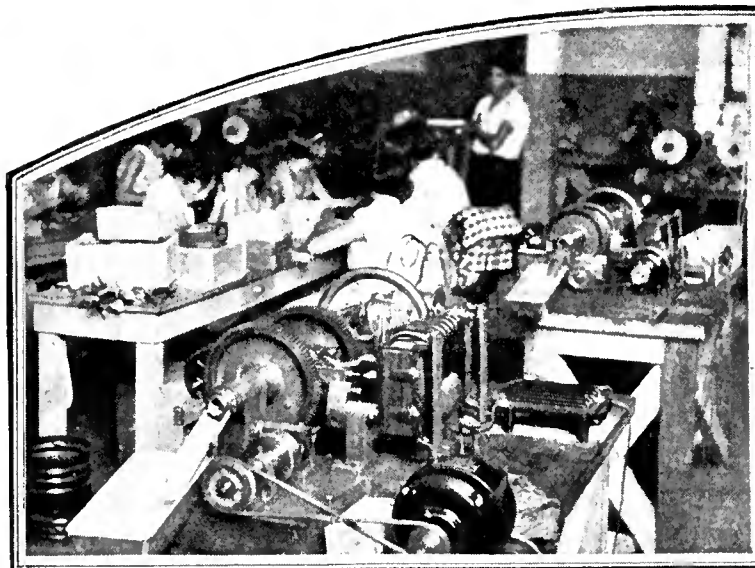
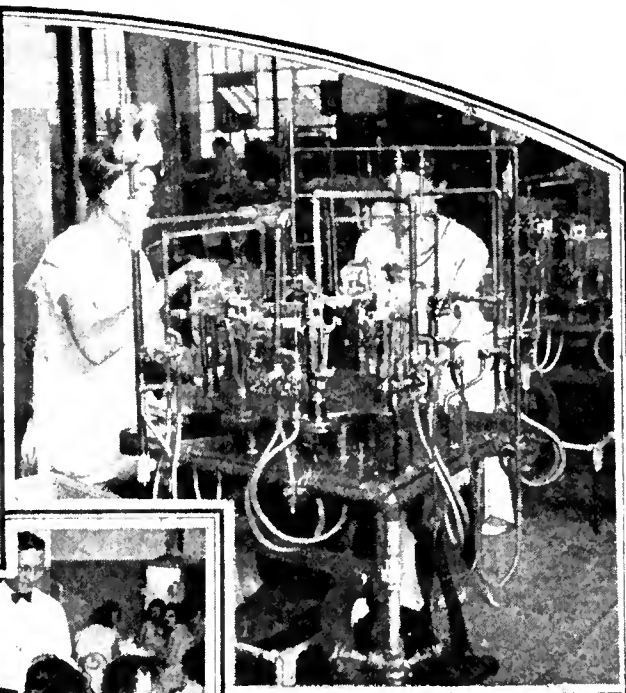

Fig. 7



*Automatic grid winding machines.*



*Stem foraging machine.  
(Left) Mounting vacuum tubes.*



*General view of assembly floor where vacuum tubes are mounted.*

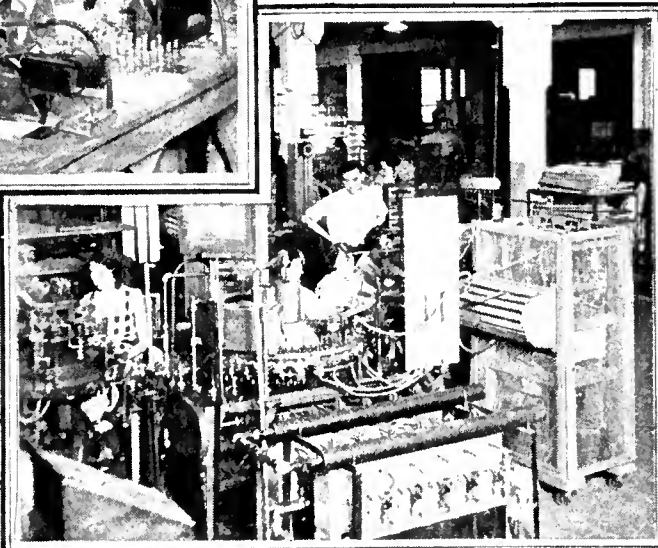

*Sealing, exhausting, basing, and soldering.  
(Below) Automatic aging rack.*

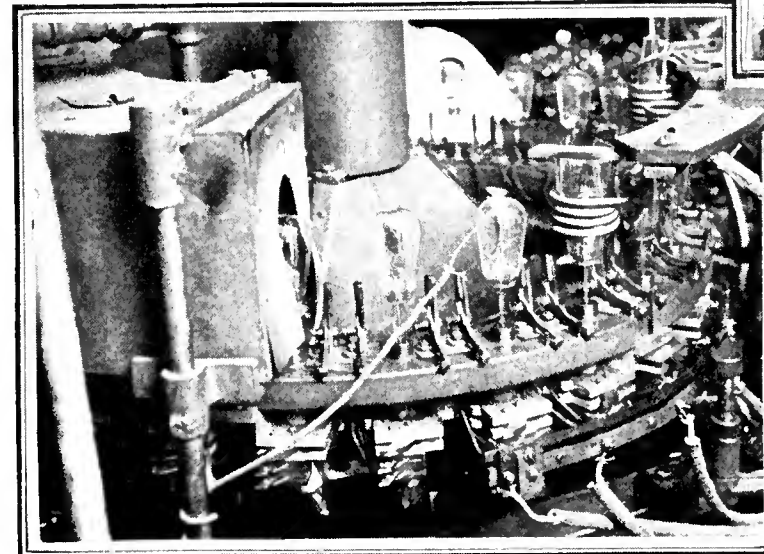

*Close-up view of exhaust machine.*

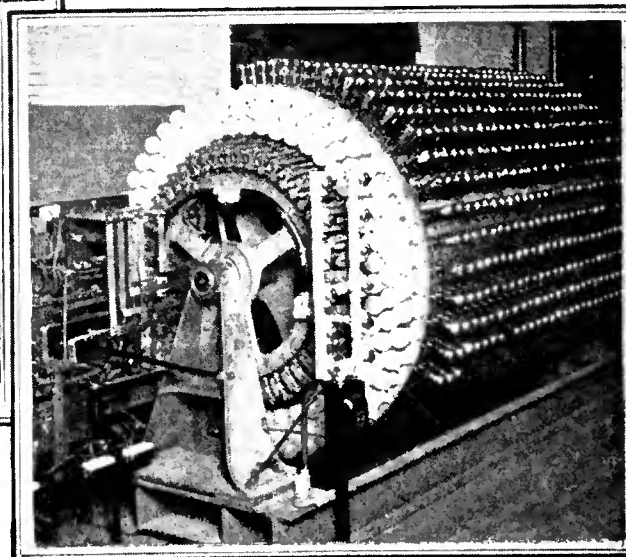

*The seven pictures on this page were taken in the factory of the Ken-Rad Corporation, Owensboro, Ky., and show the wide range of equipment required for the manufacture of radio vacuum tubes in a modern plant.*

## TUBE MANUFACTURING EQUIPMENT IN THE KEN-RAD FACTORY



# The MARCH

How Should We Advertise Radios?  
Let's Reform Before We are Stamped Unreliable

## Misleading Radio Advertising

The National Better Business Bureau recently compiled a list of the superlatives most frequently used by leading radio manufacturers in national advertising. The survey proved what everyone appreciates fully, that the industry is uniformly making the same hyperbolic claims for its product. The public knows that thirty or more brands cannot each be the "best" and that the claims of superiority of the cheaper sets can hardly be based on fact. Therefore, the effect of the large amounts spent for advertising is at best developing mere name familiarity.

The alternatives to a policy of advertising radio receivers by means of glittering generalities have become quite familiar. A halo is built around a coined word which means absolutely nothing, claims of technical superiority are based on a point which is in no way distinctive or unusual, and technical data is presented in a form which is usually correct but often quite misleading.

In the hope of being able to offer a specific suggestion for avoiding superlatives and basing advertising claims on a foundation of fact, we discussed the possible use of the procedure formulated by the Institute of Radio Engineers for rating radio receivers as a basis for making advertising claims with the chief engineer of a major manufacturer, who is a prominent leader in writing the standards of the radio industry. The three qualities which can be rated under the I. R. E. procedure are sensitivity, selectivity, and fidelity, the three basic factors determining a radio receiver's performance. But, it was pointed out, there is no specific way of evaluating the relative value of these qualities. An arbitrary system of rating must therefore be assumed in plotting comparisons of these qualities, which may easily produce misleading or meaningless results. It is somewhat like trying to judge the personalities of two men by charting such of their qualities as perseverance, integrity, and the knowledge each has of his business. With such a system of rating, a plodding bookkeeper might outrank a capable executive. A common denominator is required to make valid comparisons.

The fidelity of an audio-frequency system can be measured conveniently by comparing its electrical input and output. Such measurement, however, does not represent the overall fidelity of the complete receiver, as it fails to take into account the effect of the radio-frequency amplifier in cutting off sidebands and the ability of the reproducer to convert the range of audio frequencies supplied it into sound. Advantage is taken of public ignorance of these facts. The actual audio-frequency quality which the user experiences is dependent upon sound waves released by the reproducer and not upon the characteristics of the audio-frequency system alone.

Tone quality is the subject of the greatest advertising abuses. The best reproduction is attained by equalized gain over a band from 50 to 5000 cycles. Exaggeration of any part

of that range is undesirable and "colors" or modifies fidelity by a process of distortion. Wide range of response is of no significance unless accompanied by an accurate statement of the gain throughout the band. A boast of special quality of reproduction of one kind or another is usually an admission of unequalized gain or narrow response band. A receiver which is superior in selectivity and sensitivity alone is almost certain to be inferior in its fidelity as measured at the listener's ear.

Furthermore, the possession of the maximum audio-frequency range is a questionable advantage. Some of the best receivers employ an artificial cut-off below 5000 cycles because that

reduces the background noise and secures a better overall musical effect than is attained by permitting reproduction of higher frequencies. Sensitivity, likewise, can be excessive, contributing not only an unnecessary background noise but also rendering the receiver more liable to cross-talk from stations on neighboring channels and reducing the amplification of the higher frequencies.

Perhaps the most insidious type of misrepresentation is that based on scanty though correct engineering data. Under the cloak of laboratory measurements, entirely unjustified claims are easily made. A receiver is advertised with its reproduction described by actual figures for low- and high-frequency limits. Sometimes the low-frequency limit is so low that it could not be attained without a baffle considerably larger than can be made a part of the average console cabinet. A claim based on the frequency range of the audio-frequency amplification system means little or nothing; a fidelity curve of its performance but little more. The only quality curve that means anything is a comparison of the modulated radio-frequency input with the sound output of the reproducer throughout the audio-frequency range.

All of this leads us to no constructive purpose except perhaps to explain why generalities and superlatives predominate in receiver advertising. The most we can hope for at this time is a definite trend

toward dignified and artistic advertising and an early end to the present era of flamboyance.

One suggestion can be adopted from the automotive industry which has somewhat the same problems as radio in finding valid advertising claims. Few of the quantity producers compare their cars with those of competitors by claiming to make the best or the finest or insisting on superiority in any particular phase of performance. Comparisons are usually made only over their own last year's models to show the features wherein improvements have been made. Why not be satisfied with a statement that the latest models of a receiver line are the finest made in the company's history and refrain from comparison with those of competitors or of the general standards of the industry? Let us reform radio advertising while the public still regards it merely with tolerant amusement and before it is definitely stamped as unreliable and misleading.

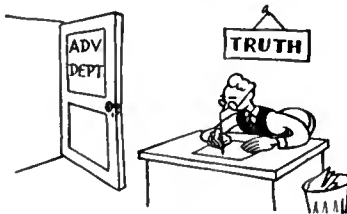

# OF RADIO

The Pentode's "Greeting" by the Industry  
A Suggestion—Move the 50,000 Watters Inland

## The Coming of the Pentode

The radio industry treated the announcement of the availability of the heater-type pentode rather rudely. The Radio Manufacturers' Association promptly issued a statement to the effect that the new tube will bring about no improvement in performance, that its use in Europe is accounted for by the fact that royalties are collected on the basis of number of tubes in a receiver, and that the tube is unlikely to make possible reductions in the cost of receiver manufacture. As long ago as March, 1928, William Dubilier reported the existence of a German pentode receiver, giving good loud speaker reproduction, with a retail selling price of \$12.00.

The industry naturally shivers with apprehension at the very thought that its present designs may be forced into obsolescence. The alternating-current tube promptly raised mountains of selling resistance to battery receivers; similarly the screen-grid tube made the three-element type unfashionable. With the high cost of research, preparation for manufacture, and marketing of new lines, and with the still substantial stocks of unsold receivers in the hands of manufacturers, jobbers, dealers, and cut-price merchants, progress is as unwelcome as a Stock Market crash.

The screen-grid tube just as appropriately could have been greeted with the argument applied to the pentode, to the effect that the performance of a pentode receiver can be equalled with existing types of tubes.

The resistance of the industry to the pentode tube is a welcome sign. Both a.c. and screen-grid receiving sets were marketed on too wide a scale before satisfactory performance could be assured the consumer. For once the industry is not welcoming innovation with undue haste. However, the very tube and set manufacturers who issue publicity to counteract sentiment toward the pentode are at the same time working feverishly in the laboratory to perfect the tube and receivers using it. The longer this process is preferred to the usual course of merchandising half-engineered receivers to an unsuspecting public, the greater will be the ultimate contribution of the pentode in broadening the market for radios. It is quite doubtful that the first pentodes to appear have ideal or perhaps even useful characteristics. A tremendous amount of work must be done before the pentode itself is fully developed and before the art of using it is acquired by set designers.

## High Power vs. City Areas

Finding that the New Jersey State Radio Commission made it too hot for the Columbia Broadcasting System's proposed

50,000-watt transmitter for WABC, the system's engineering talent directed its attention to the present location of its 5000-watt transmitter.

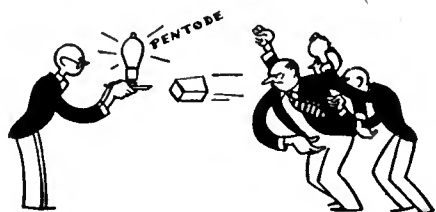

Protests were then heard from radio dealers and listeners in Brooklyn and Queens, objecting to any increase in power in that location.

The facts of the matter are that the metropolitan area of New York is much better served by 5000-watt stations located as near to the center of the area as possible, than by 50,000-watt stations sufficiently removed to avoid inconveniencing a large part of the public. No one questions the fact that WOR, within a few miles of Manhattan, delivers the highest value of field strength to a larger percentage of the metropolitan area than any other station, while two stations of 50,000 and 30,000 watts respectively, located at its fringe, deliver an inferior signal at the opposite rim of the circumference of the area.

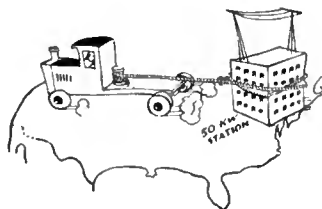

It is wholly uneconomic to locate 50,000-watt stations near metropolitan centers; they should be several hundred miles from either coast. We need only consider the example of WLW, several hundred miles from the Atlantic seaboard, which gives incomparably the best rural service of any station in the country at the present time.

It has also been demonstrated clearly that, when the Commission comes out in support of a desirable engineering trend, the broadcasting fraternity manifests an active spirit of cooperation. The very trend toward the removal of high-powered stations from the center of the metropolitan areas and the efforts of various managements to acquire several stations in their areas for the purpose of consolidation is evidence of the Commission's influence. Of course, this influence has suffered a serious blow because of the fact that, after encouraging purchases of stations for purposes of consolidation, the Commission has failed to support them. Indeed, it is, in one instance at least, terming such a consolidation as an attempt at monopoly even though the original purpose of the grouping was a response to the expressed desire of the Commission to help in eliminating stations.

However, experience has proved, first, that high-power stations, close to the eastern and western seaboard, are uneconomic, while they render their greatest service when located at the center of the country and, second, that large metropolitan areas are better served by medium- and low-powered stations in their center rather than by a high-powered station some distance away.

## Broadcasting Achievement

At the Senate hearings on the Couzens bill, William S. Paley testified that the Columbia system is giving 75 per cent. of its time on the air to "service programs made available at its own expense."

Prior to 1928, the system lost \$205,480; during 1928, \$172,000, and the accounting for 1929, it is anticipated, will show a  
(Continued on page 349)

NOTICE  
ONLY 10 SECONDS  
OF ADVERTISING  
ANNOUNCEMENTS

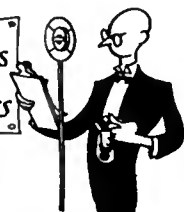

# Pertinent Notes on CHARACTERISTICS OF TELEVISION SIGNALS

By C. H. W. NASON  
Jenkins Television Corporation

THE DEVELOPMENT of television during the past two years has progressed rapidly. To say that we have passed the period of high-pressure development would be patently unwise; rather it might be said that television is in the same position to-day as was the broadcasting of music a decade back. Much has been written of television and it is the purpose of this article to review certain fundamental conceptions and facts regarding the television signal, its generation, transmission, and reception.

In considering the electrical aspects of the television signal we will accept as a basis the following facts: a vertical composition of 48 scanned lines; a degree of horizontal definition equivalent to 64 elements in a picture area having an aspect ratio of 3/4, as in a standard motion-picture frame; and a picture frequency of fifteen per second. The picture is to be scanned from left to right and from top to bottom as in reading the printed page. This degree of definition allows for a "head-and-shoulders" image equivalent in detail to a newspaper half-tone having an area of  $\frac{3}{4}$ " by 1". The effect of motion is to increase the apparent detail by some fifty per cent.

These standards are based upon our ever-present compromise between the ideal and the possible. Increasing the number of scanned lines, the horizontal definition, or the picture frequency, results in a widening of the frequency band to be covered and a further encroachment upon the capabilities of contributing apparatus.

The lowest frequency transmitted is the picture frequency, 15 cycles. The highest frequency present in a picture of the degree of definition noted above is half the number of picture elements multiplied by the frequency of repetition or—

$$\frac{48 \times 64 \times 15}{2} = 23,210 \text{ cycles.}$$

Proper delineation of photographic film,

directly scanned images, etc. requires that, in the case of radio transmission, r.f. circuits and a.f. amplifiers pass this entire band of frequencies without discrimination or distortion. Thus it may be seen that the amplifiers of accepted usage are unsuited for this service. Short-wave receivers in their ordinary form, used without regeneration, are suitable for the reception of silhouettes or "shadowgraphs," such as are now being transmitted on regular schedule in the eastern part of the country; and such receivers will allow the reception of a passably good picture, but one lacking in sharp vertical lines, should such arise.

R.F. amplifier circuits have been developed which are capable of transmitting the entire band employed without serious attenuation of the high frequencies and represent an extreme engineering refinement of the theory of coupled circuits.

## Origin of Signal

The transmitted signal has its origin in light impulses directed upon a photo-electric cell by means of a beam of light varied by the changing density of a photographic film or by the degree of light reflected from an illuminated scene.

This television signal differs widely from that of sound broadcasting, both in form and in its method of propagation. The primary signal impressed on the amplifier input from the photo-electric cell is a fluctuating unidirectional voltage of the form shown in Fig. 1. The voltage from the cell is ostensibly proportional to the illumination, the actual d.c. component about which the variations are effective being a function of the background density of the scene such as to bring the impressed voltage from the cell into the form in Fig. 2 where arbitrary values are indicated. The signal wave is therefore as shown in Fig. 3, and minus the d.c. component occurs in the form shown in Fig. 4.

The wave shown in Fig. 2 consisted of

the wave shown in Fig. 4 plus a continuous voltage of value  $a + b/2$ . The transients effective in the circuit reside in the alternating component shown in Fig. 4, since the impedance of the amplifier input circuit, as shown in Fig. 5, is infinite to zero-frequency components, i.e., no portion of the steady state direct current may flow.

## Aperture Distortion

We have considered the necessary characteristics of a.f. and r.f. amplifiers for television service and have noted the gain-frequency performance required. There is, however, a distortion present not due to circuit deficiencies. For example, actually the form is altered by aperture distortion of the wave caused by the passing of the aperture over a change in light intensity, for a square aperture will not give a rectangular wave form as shown in Fig. 6, as is desired, but alters the wave form in the manner indicated in Fig. 7, where  $T'$  the time required for the passage of the aperture over the line in the picture corresponding to the origin of the change in light intensity.

A Fourier's analysis of the wave form in Fig. 8 gives—

$$e = \frac{E}{\pi} \int_0^{\infty} \frac{1}{\omega} \left( \frac{\sin \omega T'/2}{\omega T'/2} \right) \sin \omega t \, d\omega$$

This differs from the instantaneous values for the rectangular form by the factor within the parenthesis, the distortion from the ideal being one of amplitude versus frequency, with but slight phase distortion over the spectrum. It is necessary, therefore, to correct over the frequency band for the factor—

$$\frac{\sin \omega T'/2}{\omega T'/2}$$

The equations for the round aperture are more involved, "Sin" being replaced by the Bessels function of the first order

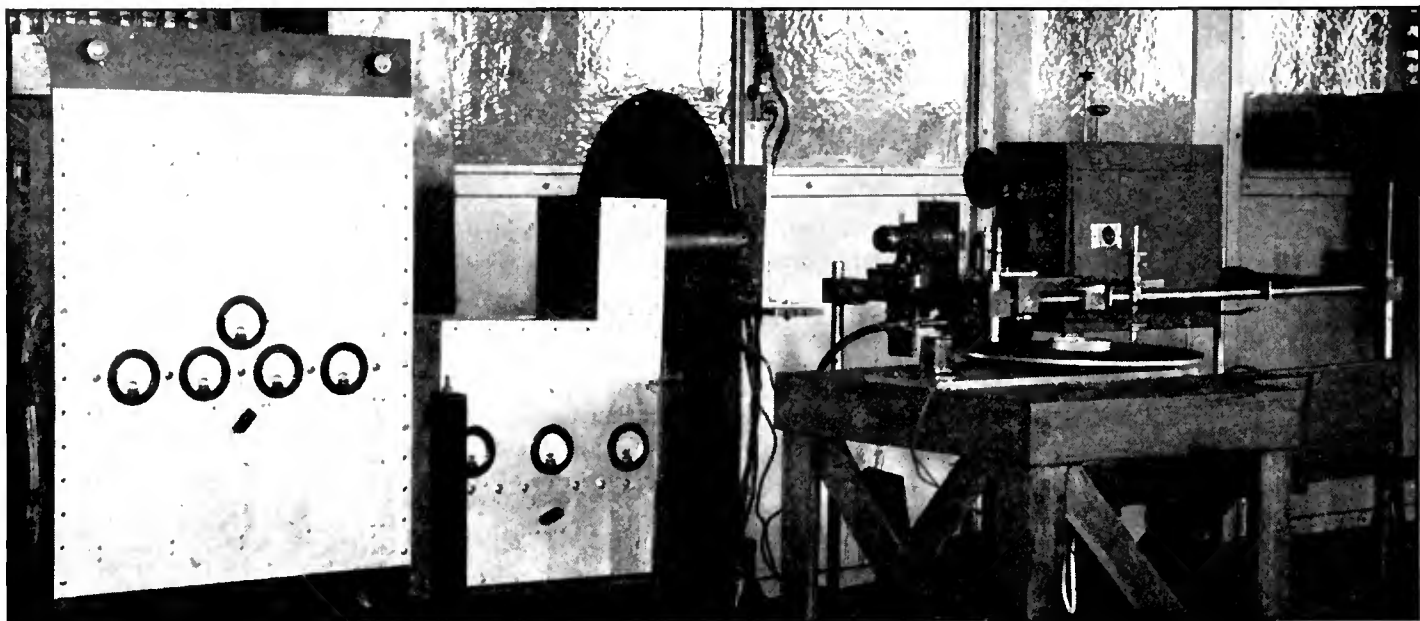

The latest Jenkins transmitting scanning system with shielded amplifiers and a synchronously driven pick-up for transmitting "radio talkies."

# The Frequency Band Required for Television. Mathematical Discussions of the Various Frequency Components. Neon-Tube Circuits. Methods of Synchronizing.

which is far beyond the scope of this article. The numeric values are substantially the same as those for the square aperture and they may be taken as equal without serious error arising from the assumption.

The effect of the aperture distortion as shown in Figs. 7 and 8 may be evaluated by use of the Fourier's theorem which states, briefly, that a complex wave may be analyzed as being composed of a number of sine waves of differing wavelength, amplitude, and phase superposed one upon the other.

## Size of Aperture

The aperture as applied to the scanned scene should preferably be 1/48 of the total height, as overlap or spacing between the scanned lines is not desirable except in special cases. This clearly defines the factor T' and the frequency discrimination may be computed algebraically. This amplitude-frequency distortion may be compensated by a corrective network having little distortion of phase. Fig. 11 (page 357) illustrates the distortion occurring. Variations in the overall characteristic of plus or minus 20 per cent. are allowable without noticeable deterioration

of the image. Phase distortion ( $\frac{d\phi}{d\omega}$ ) with frequency is not permissible in a degree of more than 10 to 20 microseconds except at the low frequencies where phase variations with frequency may be fairly large. This latter form of distortion is not usually found except where long land lines are employed for the transfer of the signal or where transformers are employed as coupling elements. Corrective networks have been developed which will compensate phase distortion without affecting the other characteristics of the circuit.

As was noted, the d.c. component of the initial signal is a function of the general

tone of the transmitted scene or the character of its background. Proper reception of the image is dependent, therefore, upon the initial illumination of the neon tubes and must be obtained by adjustment for the most pleasing appearance or by previous knowledge of the characteristics of the scene. Neon tubes employed in television reception must be essentially free from any effects of hysteresis, and their curves must be linear over a wide range. (See Fig. 12)

## The Neon Tube

The neon tube may be adjusted for the proper background density by varying the plate current of the output tube. This may be done by adjusting the grid bias of the output stage, together with the plate voltage in such a manner as to continue the operation of the tube at a favorable point on its characteristic curve according to the circuit diagram in Fig. 9. A more suitable method, though more profligate in battery use, is shown in Fig. 10 where any tendency toward improper operation of the tube is avoided. Here the steady plate current of the vacuum tube is balanced out of the neon tube circuit. "R," as indicated, is made equal to the plate resistance of the tube, and the voltage of the balancing battery is adjusted for the desired current through the neon tube.

The neon tubes now on the market present varied load according to their mechanical construction and the gas with which they are filled. Those available have

an a.c. impedance of anywhere between 1000 and 8000 ohms. The d.c. resistance of the tube involves a voltage drop which must be taken into account where economy of voltages is a factor, but in general the high-impedance type is preferable when considered as the load circuit of a vacuum tube, as a load impedance considerably higher than that of the plate circuit of the output tubes usually employed in the output stage means that there will be but little curvature to the dynamic characteristic of the circuit.

The same characteristics which make the d.c. drop high, keep the inter-element capacitance of the tube down and render the impedance mostly resistive even at the highest frequencies encountered.

## Synchronization

The synchronization of the scanning mechanisms at the transmitting and receiving ends presents an involved problem not only in the field of communications engineering, but in electrical and mechanical engineering as well. The simplest method is adaptable only where the a.c. power networks at the transmitter and receiver are interconnected. In this case it

(Continued on page 357)

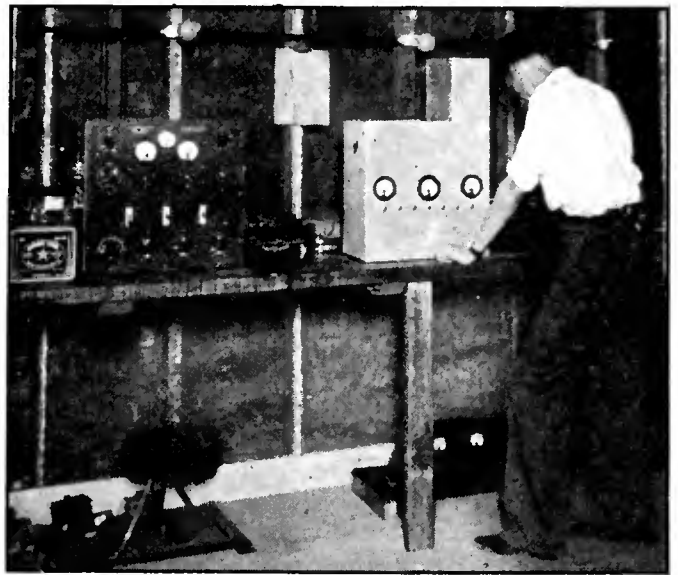

The shielded room in which television signals are measured at the Jenkins Television Corp.

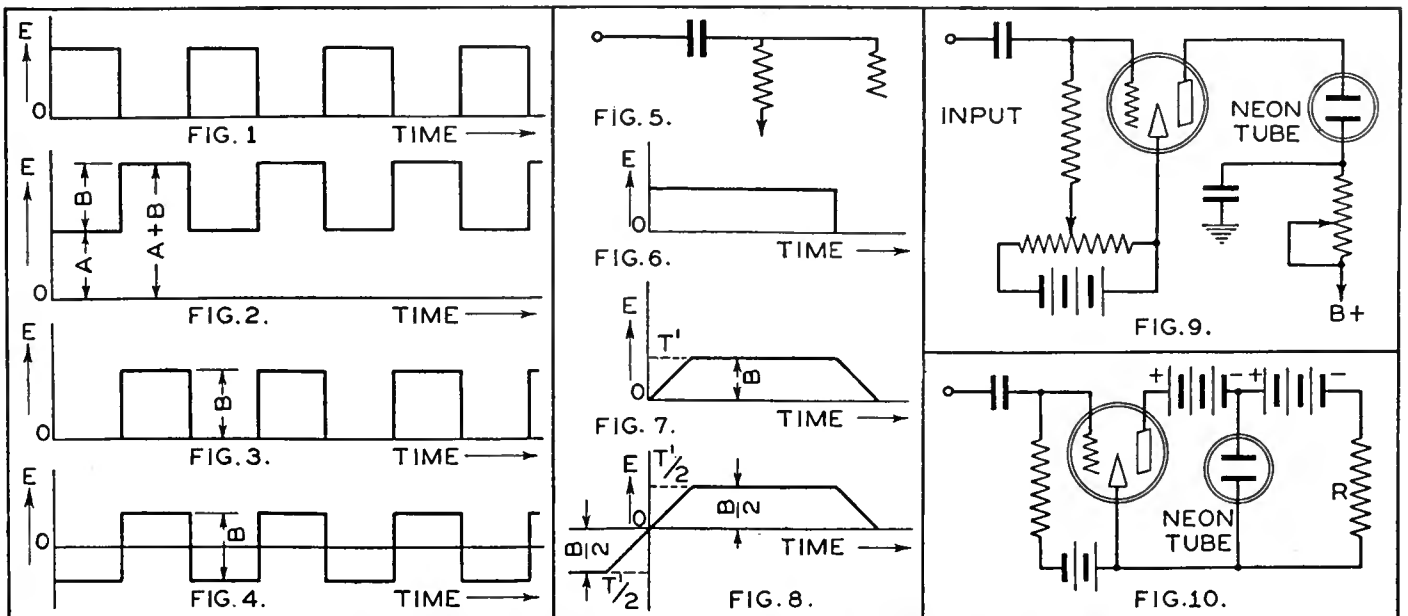

The eight schematic drawings shown above explain the physical aspects of the radio television signal and show two typical neon-tube circuits.



# AUTOMOBILE RECEIVER DESIGN

BY ROBERT S. KRUSE.  
*Radio Consultant*

*Complete Description and Discussion of the Characteristics of the Bosch Automobile Radio Receiver. Special Problems in the Design of Such Receivers.*

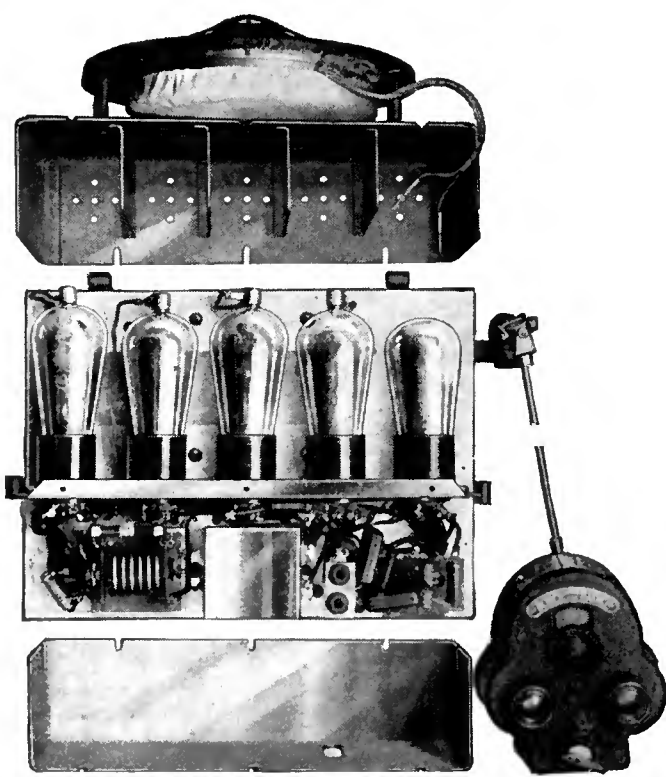

An "exploded" view of the Bosch automobile radio chassis.

THE AUTOMOBILE radio receiver is older than broadcasting. Indeed, the combination of a motor car and a radio receiver was so obvious that many of us made suitable sets in the days when there was nothing to be heard save dots, dashes, and static. When entertainment broadcasting arrived installations were made in larger numbers but without any popular response, despite pictorial publicity in magazines and newspapers. The lack of any general response was due to apparatus limitations, not to any lack in the idea.

Many months ago the Radio Frequency Laboratories, Inc. initiated the familiar process of measurement, calculation, and test which resulted in a working model of a broadcast receiver for use in automobiles. After suitable road and laboratory tests, this model was turned over to the engineering department of the American Bosch Magneto Corporation where it became the basis for additional work. A production model was developed and this also required much measurement and testing by W. F. Cotter and B. V. K. French under the direction of Chief Engineer L. F. Curtis.

This production receiver is discussed in this article. The background for the earlier work on the Bosch automobile receiver may be obtained, to some extent, from reading the paper by Paul O. Farnham, given at the Eastern Great Lakes District Convention, I.R.E., Nov. 19, which will appear shortly in the I.R.E. *Proceedings* under the title "A Broadcast Receiver for Use in Automobiles." A paper on the same subject by W. D. Loughlin has been given limited circulation in the R.F.L. "Preliminary Engineering Report, No. 3."

### The Conditions

It is evident that the automobile receiver must operate with a very limited antenna and yet deliver a moderate loud

speaker signal. A very simple calculation shows that the sensitivity must be equal to that of a good broadcast receiver; in other words, the set must have a sensitivity in the region of perhaps 20 microvolts total input when it is giving an output of 80 milliwatts. This rating, not the I.R.E. standard, is used because this power output gives reasonable volume, a departure to be explained later. This performance must be obtained with economy of space, weight, and battery demand. Furthermore, the construction must be dirt-proof and unaffected by vibration, and, auxiliary to the main problem is the need for a semi-remote control and the suppression of ignition noises.

### General Arrangement

There are several points of interest in connection with a typical Bosch automobile receiver installation. In the first place, a "roof" antenna is not used and the dash is left wholly unchanged except for the mounting of a small control unit. The set itself is supported by flanges resting in

rubber-lined channels which in turn are carried by brackets bolted to the engine bulkhead. The loud speaker may be mounted directly on the set or may be located in another manner which will be explained in a later paragraph. Unlike some forms of mounting this system does not require reconstruction of the car, nor any special design for a new car. No existing car has yet been found in which the equipment cannot be installed. At this writing all service stations of the American Bosch Magneto Corporation are equipped to make radio installations on all types of automobiles and several manufacturers of cars have listed the set as standard factory equipment.

Collecting signal voltages and at the same time avoiding the pick-up of too much ignition and generator noise is a problem which has caused the appearance of various types of antennas on motor cars for the last 15 years or so. The antenna has usually been concealed in the car roof—certainly the poorest place that could be conceived. Placed between the grounded rooflight and the grounded metal portions of the roof (extended up from the car sides), the effective height cannot exceed a few centimeters. Furthermore, the location is one nearly ideal for the collection of the maximum ignition noise, since the antenna is above and the counterpoise (car frame) below the ignition system. Also, the dome light wiring contributes noise to a roof antenna which is difficult to filter satisfactorily. In addition to this the antenna cannot be installed in a used car except by tearing down the roof upholstery.

The use of the "sub-car" antenna (consisting of a metal plate under the car), shown in Fig. 1, altogether avoids the last difficulty, decreases the ignition noise materially by collecting the signal in the clear space below the car frame, has

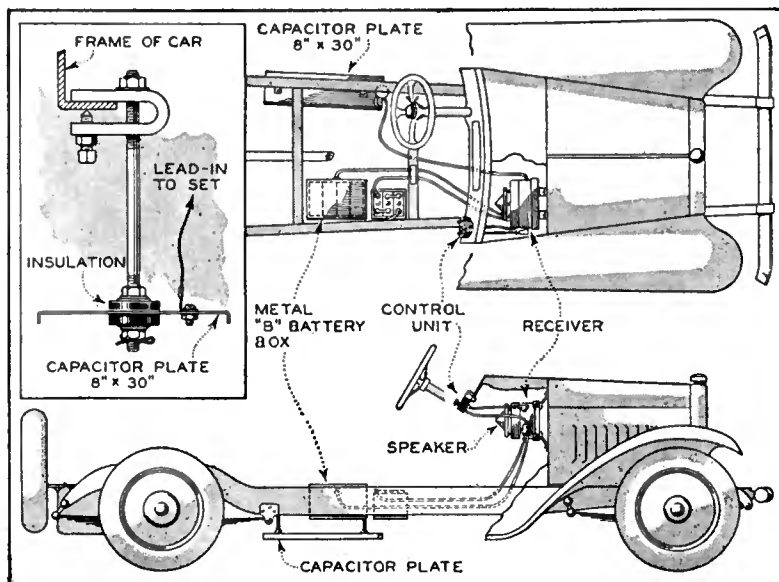

Fig. 1—Schematic drawing of a typical Bosch motor car radio installation.

an equal or better "effective height," and offers a special advantage of its own. This special advantage is that the antenna is near the set and therefore the lead-in wire is short and moderately clear of grounded (connected to frame) metal parts. The capacity of the lead-in wire is accordingly moderate and does not vary extremely from one installation to another, thereby making it possible to secure tuning condenser alignment without the need of anything beyond the normal trimming condenser on each section of the gang variable condenser.

The antenna system is electrically equivalent to Fig. 4, where  $C_{af}$  is the capacity between the antenna plate and the car frame,  $C_{ea}$  is the capacity between the earth and the antenna plate, and  $C_{ef}$  is the capacity between the earth and the car frame. A signal arriving at the car will produce r.f. potentials across all three of these capacities, the combination of which will be effective in supplying voltage to the receiver. In the average installation the antenna-frame capacity,  $C_{af}$ , has a value near 0.000125 microfarads, across which is shunted the resultant of the other two capacities in series. This resultant is also about 0.000125 microfarads in the average installation.

Thus the whole is in one sense equivalent to a capacity of 0.00025 microfarads connected across the input terminals of the set. This accounts for the somewhat vague statement on Fig. 5: "Antenna through 250 mmfds."

Actually the r.f. energy is fed from antenna to set through a simple r.f. transmission line, the purpose of which is to permit the transfer to be made at such a low potential that capacity effects are of no importance, regardless of the distance between set and antenna. There is a step-down r.f. transformer at the antenna and a step-up terminating transformer inside the set, the latter appearing as the first transformer in the general diagram of connections, Fig. 3. Between the two transformers is the shielded two-wire line in which the potentials are so low that the length of the line and its location with regard to metallic parts of the car is of little importance. In its present form

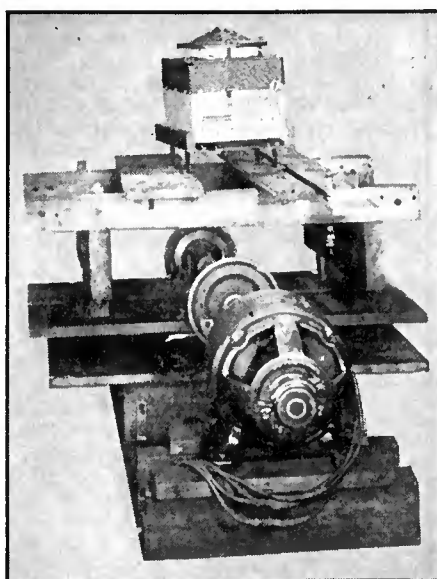

Fig. 2—This apparatus is used to determine the effect of continued vibrations on receiver performance.

this r.f. transmission system produces materially better signal strengths than were obtained with the antenna led directly to the set in the usual manner of motor car sets.

### The Receiver

Having arrived at the set we find, as expected, that it is enclosed in a substantial metal case. The design of this case is such that access to the tubes is obtained by loosening three knurled thumb screws and removing the upper portion of the front, which also carries the intertube "fences." There are no loose tube shields or cans. If for any reason the various resistors or by-pass condensers require inspection they may be reached by removing the lower portion of the casing. Both of these points are made quite clear by the "exploded" view of the receiver, the heading illustration. This picture also shows the

arrangement of parts in the lower compartment where the fixed r.f. transformer is located.

In the "exploded" view it will be seen that the upper portion of the casing carries the loud speaker. The tuning control of the set is by means of a gang condenser the shaft of which terminates in a spiral gear, meshing with another gear in the small housing seen at the upper right of the main body of the set. From this point the control is carried to the control head on the dash by means of a splined shaft of adjustable length, connected to the control head and to the set through universal joints. This seemingly complex arrangement was chosen after experience which thoroughly disclosed the unsatisfactory performance obtained from flexible shafts of the simpler design. The principle difficulty about such shafts is that they introduce considerable "slack" or "give," making it impossible to calibrate the dash control, since a station tuned-in at 56 when turning in one direction may appear at 51 when tuning in the reverse direction. In addition to this there is the troublesome tendency of the usual flexible shaft to "wind up" and then suddenly "flip" the tuning unit in the set forward, making it difficult or impossible to stop at a desired point.

The right-hand knob on the control head operates the vernier dial, which is of the "line-of-light" type. This type of dial permits correct reading from any position in the car. The opportunities for parallax with ordinary dials are excellent and the precaution is worth while since it is risky for a driver to lean to the right in reading the tuning scale. The translucent scale, though having only 100 divisions, covers an arc of 312 degrees, thus providing great ease of tuning. To provide this ease of adjustment a reduction of 3.25 to 1 is introduced between the tuning knob and dial scale and an additional 5.6/1 reduction is placed between the tuning knob and three-gang condenser. The left-hand knob on the control head operates the volume control rheostat and at the lower center of the control head is a key-switch which may be used to lock the set when desired.

The design of the set is such that during

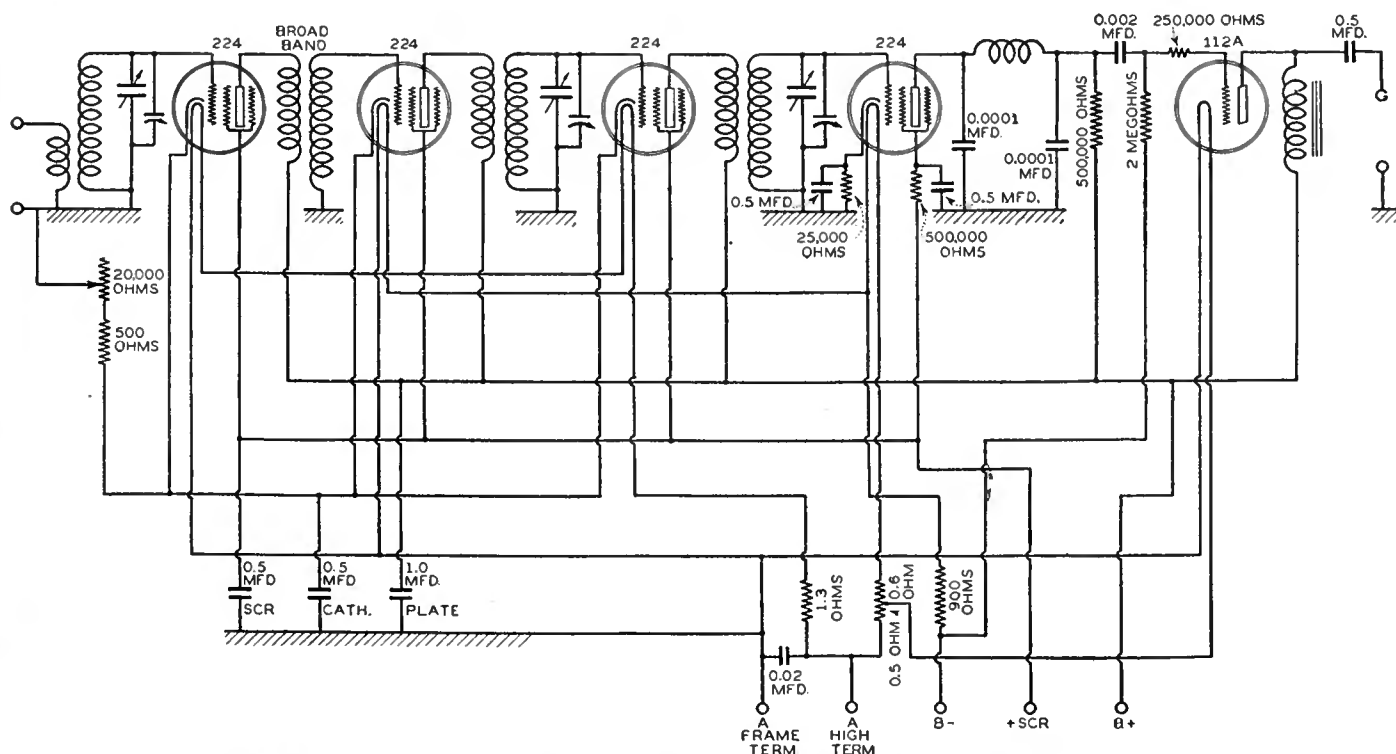

Fig. 3—The complete schematic diagram of the Bosch motor car receiver chassis.

manufacture it may be sub-assembled, the main set body forming one assembly with the tuning gang-condenser in place, while the second assembly consists of the section carrying sockets, r.f. transformers, output choke, and the various resistors and fixed condensers. The removable portions of the case are handled independently, as are the control head and the control shaft.

The design of the mounting brackets is such that when desired the set can be removed from the car either with or without the brackets. The alignment condensers are accessible when the set is in place.

### The Circuit

To be of any real use to the average automobile owner an automobile radio receiver must not merely perform within 40 or 50 miles of a station but must be useful in a goodly percentage of all the possible locations in the United States, at least. It has been said that under motor-car conditions this calls for sensitivity of the order of 20 microvolts at the antenna, for 80 milliwatts of audio-frequency output. This performance calls for a voltage gain in the vicinity of 2,000,000 between antenna and loud speaker, using the customary reference to equal impedances at input and output. This may be obtained in a reasonable number of stages with screen-grid tubes by allowing some of the gain to take place in the detector and audio-frequency amplifier.

The first question to be decided is that of the number of r.f. and a.f. stages to be employed. By general agreement a single a.f. stage is preferable if the amplification of the r.f. system is adequate. On the other hand, multiplication of the r.f. stages cannot be carried to extremes since this tends to increase the size of the set by adding bulky r.f. transformers and condensers. In the Bosch automobile receiver three r.f. stages are used to secure a voltage gain of about 60,000. With 20 microvolts input this amplifier delivers about 0.6 volt to the detector.

From the diagram of connections (Fig. 3) and also the pictures it will be seen that the coupling between the first and second r.f. tubes is of the "untuned" variety. Special design of this broad-band transformer permits a gain-curve which is not only comparable to that of a good tuned transformer as to height but also has an advantageous shape. Inspection of the chart of sensitivity curves (Fig. 5) will show a general tendency of the tuned stages to drop off toward the low-frequency end in the familiar manner. The broad-band transformer is accordingly designed for maximum response in the region of 600 kilocycles, causing a sharp divergence between the "first-grid" and "second-grid" curves, and a nearly flat curve for the antenna. Thus, the fixed coupling is not a mere concession to space limitations but a means of obtaining a desirable response curve for the set as a whole.

The selectivity obtained with three tuned circuits in an amplifier with such high gain would not be satisfactory for ordinary home use. It is to be remembered, however, that the pick-up is very limited and the general level quite low so that the "useful selectivity" (the term is admittedly home-made) is entirely satisfactory.

The construction of the broad-band

transformer is simple. It consists of a grooved form in which two wires are wound together, one later to act as primary and the other as secondary. The winding is a "random" one. The purpose of winding in a number of slots instead of a single large groove is to secure an improved L/C ratio and a higher output voltage for the grid of the second tube. The winding speed, tension, wire size, type of insulation, number and form of grooves and number of

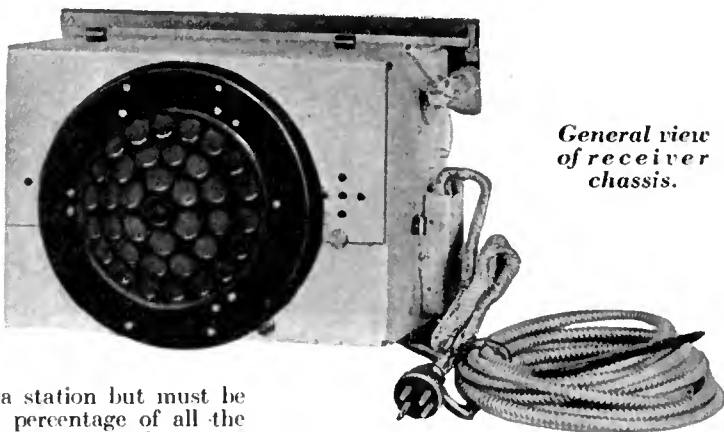

General view of receiver chassis.

turns all contribute to determine the response curve.

The screen grids of the r.f. tubes are maintained at a fixed potential by a tap from the plate battery at 90 volts. Control by variation of the screen voltage is not regarded as suitable since the sensitivity of an r.f. amplifier varies in anything but a linear manner when the screen voltage is changed. The control is accordingly referred to the cathode bias which is obtained by plate-current drop through an adjustable resistor in the control head. This rheostat has a maximum value of 20,000 ohms, which is adequate in the presence of very strong signals. In series with the volume-control resistor is a 500-ohm fixed resistor to provide a minimum bias suitable for weak signals.

### Detector and A.F. Amplifier

The fourth screen-grid tube is operated as a "plate" detector and adds somewhat to the overall r.f. gain. The cathode bias of this tube is obtained in the usual way through IR drop. The screen-grid is supplied with a positive bias from the same battery tap which feeds the other screen grids in the set. However, an 0.5-megohm resistor is placed in the lead to the screen grid causing the bias to assume a "rest" value below 90 volts. For low signal levels on the detector-grid, the screen-grid voltage is such as to provide maximum sensitivity. For strong signal levels, the d.c. screen-grid voltage, as well as the d.c. plate voltage, is lowered so as to maintain a reasonably large margin of difference. In this way a higher audio-frequency output may be obtained before the plate circuit of the detector is overloaded. At the same time, for large impressed signals, the response of the detector will be nearly a linear function of the input voltage.

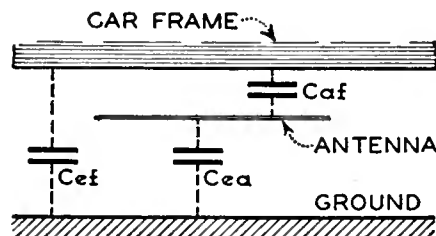

Fig. 4

Where space and weight limitations are as severe as in the automobile receiver the most practical coupling to follow this type of detector is the resistance-capacity-resistance type. In order to prevent radio-frequency feedback originating in the detector plate circuit and coupling with the r.f. amplifier, a "PI" section filter is inserted at the plate of the detector tube. This filter consists of an 11-millihenry choke and two 0.0001-microfarad condensers. In series with the grid of the audio-frequency tube is placed an 0.25-megohm resistor, the function of which is to modify the character of an audio-frequency overload in the grid circuit of the last tube, and incidentally to provide another section of r.f. filter in the detector plate circuit. The effect is quite unmistakable and immediately calls attention to the volume control, but does not mistreat one's ears as unmercifully as an ordinary overload. This is not equivalent to saying that the full output of the tube is in any way sacrificed. On the contrary, the tube is being operated with 180 volts on the plate, with proper grid bias, and is as thoroughly capable of delivering its rating as in any other receiver.

### The Audio Level

Most motor cars have closed bodies and the automobile receiver designer assumes such a body in making his design. Even a large sedan is very small when considered as a room and the sound levels to which we are accustomed may be obtained with a relatively small a.f. output from the set and loud speaker. In addition to this, the dimensions of the ordinary car are such as to introduce a tendency towards strong low-pitched resonances. This can be understood easily by recalling the deep rumblings of many sedans of 5 or 6 years ago. In such a space a normal a.f. system would be wholly intolerable; in fact one may say that a good a.f. system for this purpose must be one which will sound very weak on the low notes when operated in the open. This is fortunate since the low notes are the ones which usually enforce the use of large output tubes with their resultant heavy battery drain and bulky loud speakers. Since dry-cell batteries must be used in the present automobile receivers it is most fortunate that the conditions not only permit the 112A-type tube but almost enforce its use—especially as its gain is some three times that of the 171A-type tube.

### Special Circuit Features

Some motor cars have the negative terminal of the storage battery "grounded" to the frame, while others ground the positive. Provision is made for this by a circuit arrangement shown in the general circuit diagram. The B- is not returned to the A battery but to the junction point of one of the series pairs of 224 heaters. Thus if we assume the A battery to be reversed the bias of the 112A tube will simply be shifted from a point 2½ volts removed from A+ to a point 2½ volts removed from A- or a total shift of approximately 1 volt. Even at the "Battery gassing" potential of 7½ volts the 112A tube filament operates at a voltage very slightly above 5, hence the change in bias is negligible. The plate voltages are all changed slightly but the percentage is unimportant, as is the change in screen-grid voltages. The cathode bias of the 224-type r.f. tubes is changed very slightly but this merely necessitates altering the setting of the gain (volume) control for a given signal. Even for weak signals the change is small enough to escape notice under ordinary conditions.

It is accordingly satisfactory to install the set "as is" in any car regardless of A

battery polarity, simply grounding the "frame." A terminal and connecting the "high" terminal to the remaining side of the A battery.

The choice of the proper audio-frequency output tube has been discussed sufficiently, and the 112A-type tube is considered satisfactory from all standpoints, including filament demand. In the r.f. portion of the system the present standard types of tubes leave no choice except that between the screen-grid 222 type and the screen-grid 224 type—since the 201A and similar tubes are clearly incapable of providing a gain which will give comparable performance. The 222 is somewhat attractive because of its low filament demand but its extremely microphonic nature and associated fragility rule it out. Also, like the 201A, it is rather hopeless in a situation where the A potential varies rapidly from 6 to 7½ volts as the engine speed changes. Both the 201A and the 222 will follow these voltage changes rapidly and give intolerable shifts of intensity unless specially protected. Of the present tubes the 224 is by far the best. The considerable time-lag of the heater-emitter system comfortably smoothes over the voltage fluctuations, also normal performance of the tube can be obtained over a wider range of fixed voltages than is possible with the 201A or 222. Thus a partly "flat" battery or one being steadily overcharged is not fatal. The use of three 224 heaters in series has been proposed repeatedly, but when the IR drop in the leads is allowed, such an arrangement is on the ragged edge and will drop rapidly in performance whenever the battery is "down."

The 0.02-microfarad low-inductance condenser across the A battery terminals of the set is an r.f. bypass.

### The Loud Speaker

The loud speaker is a free-edge cone designed for motor car conditions; that is to say, for such a response-curve as will result in satisfactory reproduction inside a motor car, and to survive the severe mechanical and climatic treatment received. It is enclosed in a stamped steel shell, strong enough to stand up under accidental kicks and jars when mounted on the set under the cowl, but so finished that it presents a good appearance when mounted on the ceiling or in an upper rear corner of the car. The cone itself is waterproofed and survives exposure to sprays. The perforated rear shell is constructed in a manner which provides a sufficient number of openings to prevent resonances inside the shell. Dirt and bugs are prevented from entering through the openings by a cloth sack which is shown in place in the exploded view of the set. By careful design the overall thickness of the shell has been kept down to 2½ inches. When mounted on the set the whole projects but 10 inches from the bulkhead. This sounds larger than it is—or rather the space under the cowl is larger than one ordinarily thinks. The leg room in a small car such as the Essex coach is not noticeably interfered with by such an installation.

A bracket is supplied with the set by means of which the loud speaker may be mounted on the ceiling or in any other position in the car interior. A phone cord is also provided so that the loud speaker may be connected to the set as before by means of the same pin jacks. The loud speaker lead does not carry the plate supply voltage and may be run as desired.

For compactness the location of the loud speaker on the set is an advantage but there are acoustic difficulties. The space under the cowl tends to cause "boomy" resonances; also there may occur what we have called "overcoat attenuation," whenever the right-front seat is occupied

by anyone wearing a heavy overcoat which obstructs the free radiation of sound. This is most noticeable in the rear seat.

### Battery Supply

The filaments are supplied through an armored cable from the car's storage battery. The plate supply is obtained from four medium-duty 45-volt B battery blocks carried in a metal battery box under the car, as shown in Fig. 1. This box has a

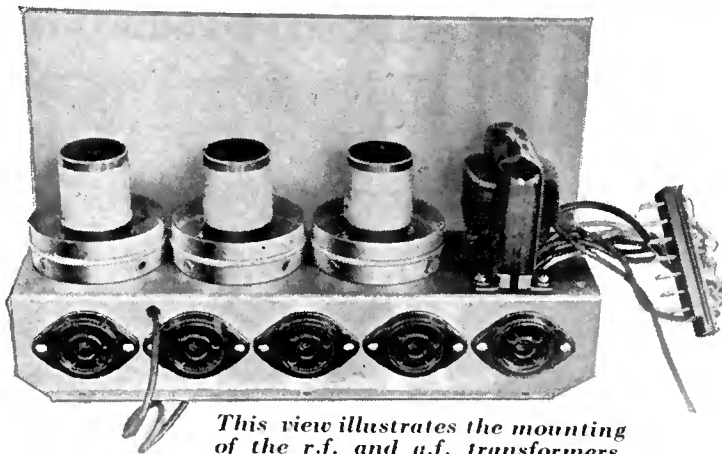

This view illustrates the mounting of the r.f. and a.f. transformers.

gasket to make it weatherproof. The cable to the set is again an armored one. The total filament current taken from the car's battery is 3.75 amperes.

### Ignition Interference

Even with sets of very modest performance, motor car installations have been characterized by extensive ignition shielding and numerous by-pass condensers under the hood. These things are almost unnecessary in Bosch installations, despite the unusually high amplification. This has been partly accounted for by the collector system and the armored cables from batteries, as well as the metal case for B batteries. The A battery by-pass condenser at the set contributes also. As the writer has said many times in other papers, the electrical disturbances set up by a motor car are mainly on wavelengths below 10 meters. A broadcast-wavelength receiver with good selectivity, well shielded, and maintained well away from any tendency toward oscillation is inherently rather opaque to such disturbances.

However, the severity of the interference may be reduced greatly by introducing a high resistance between the spark coil and the distributor and the distributor and spark plugs, thereby making the dis-

charge assume the form of a pulse rather than a train of oscillations. Such resistors are supplied with the set. They have standard terminals and are readily applied.

Since dirty charging-generator commutators may cause noises, or disturbances may wander into the set from the ignition switch, a pair of by-pass condensers is provided for shunting across these two units.

There is no other shielding or alteration of the ignition system, yet the noise level

with full sensitivity is barely perceptible at the low-frequency end of the tuner scale and rises at the high-frequency end only sufficiently to permit one to hear it with the car stationary and no signals arriving. The level is lower than that of the hum from a good a.c. receiver.

To test the effect of continued vibration without unreasonable delay the machine

shown in Fig. 2 has been used. It consists of a spring-mounted platform which carries two bearings in which revolves a shaft carrying an eccentric weight. The shaft is revolved at 1800 r.p.m. by means of a flexible shaft connected to the motor. The set is secured to the spring-mounted platform, either in the position shown or in the normal mounting position. The present construction survives this vibration test indefinitely without damage to either set or tubes.

Many road tests have been made over trips of some length. Also there has been much testing in and about different cities, as many sets will certainly be used principally under city conditions.

Because Hartford, Conn.—the writer's home town—is universally considered a radio "hole," the Bosch receiver has been tested repeatedly in this vicinity. The scene of the first tests was a location romantically named "Buena Vista" and considered good—for Hartford. Here it was found that good loud speaker volume could be obtained from wbz at Springfield, Mass. (27 miles), wjz, Bound Brook, N. J. (100 miles), wnac, Boston (perhaps 110 miles), wgn at Chicago (900 miles), and wmaq, also at Chicago. Several other stations, received rather well, were not identified for lack of time.

It is usually rash to predict radio results by analogy. However, the writer has been carrying receivers about by bicycle, train, wagon and motor car for the past 19 years and during this haphazard exploration of some 25 states has gained much confidence in the belief that Hartford stands well down at the bottom of the scale of radio reception. It seems not too rash to suggest that the quite good performances obtained in many tests about Hartford are reliable indicators of a materially better performance at almost all other points, an opinion confirmed by a number of other observers.

Speaking for himself, the writer offers the opinion that at a majority of the places in the United States satisfactory entertainment-reception would be possible during the hours when any amount of broadcasting is going on—assuming always that there is no local thunderstorm and that the road is not too villainous. If the prediction has the sound of a free advertisement, let it be so. I assure you that it is actually quite free, and given in appreciation of a really nice piece of work.

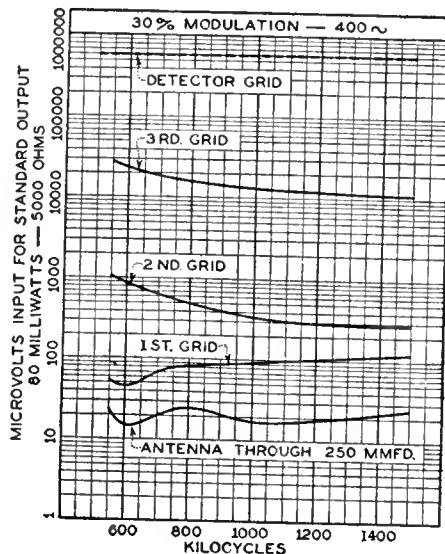

Fig. 5





Rear view of audio-frequency voltmeter.

WHILE ENGAGED in activities concerned with the development of audio-frequency amplifiers it is necessary to have at hand apparatus by which the values of input and output voltages of the amplifier can be determined. There is very little difficulty associated with input voltage determinations. It may be accomplished, for instance, by measuring the audio-frequency current flowing through a resistor of known value across which are connected the input terminals of the amplifier, the voltage being the product of the current and resistance. But determinations of output voltage are not accomplished as easily. To the output terminals of an amplifier is connected a load which in measurement practice usually is a resistor, and in service some sort of loud speaker. Now any device placed across this load for the purpose of measuring the voltage across it must satisfy three conditions: the current passed by the device must be very small compared with that flowing through the load; the indications of the device must be independent of frequency over the audio-frequency range (30 to 10,000 cycles); and the indications of the device must be controlled by the effective rather than by the peak or average value of voltage across the load.

A voltmeter has been developed to satisfy these three conditions and also to cover a sufficiently large range of voltages to adapt it to measurements identified with phonograph and broadcast amplifiers.

The two pictures accompanying this article show the external appearance and the arrangement of the various parts of the voltmeter. An additional feature of this apparatus is a unit called the load device. This occupies the bottom panel of the voltmeter. The usefulness of this device may be judged from a consideration of the conditions under

# Some Developments in HIGH-FREQUENCY MEASURING EQUIPMENT

By H. D. OAKLEY  
General Electric Company

which measurements on a.f. amplifiers are made.

Audio-frequency amplifiers make use of vacuum tubes and, when making measurements to determine their characteristics and power output, it is usual practice to terminate the amplifier (i.e., load the output tube) with a resistor the value of which is specified by the tube manufacturer. It is convenient, therefore, to have a variable resistor with which any value of resistance likely to be used in the measurements can be easily and quickly obtained. Also when using a resistance load it is wise to supervise proceedings with a loud speaker or a pair of phones connected across the load resistor—being certain,

however, that the impedance of the loud speaker or phone circuit is many times that of the load resistor so that no appreciable errors will be introduced in the measurements. There is still another condition encountered in this class of measurement. It has to do with the type of output circuit used in the amplifier. For example, in some amplifiers the d.c. supply for the last tube passes through the load resistor but in others it does not. When this second condition prevails, the supply must reach the tube through a high-impedance reactor and the load resistor must be connected to the output tube through a low-reactance capacitor. The circuit for this second condition is called the shunt-fed type, the first being the series type.

The loading device attends to all these little details. It consists of a decade resistor box with which any desired value of load resistance can be obtained, a large reactor and large condenser for shunt fed circuits, pin jacks for a loud speaker, a 100,000-ohm resistor which can be included or excluded from the loud speaker circuit, and two key switches. Each switch has three positions, those for one being "Choke," "Neutral," and "Resistance," and for the other "Monitor," "Neutral," and "Loud speaker." On the front of the loading device are two binding posts marked "High" and "Low." The output terminals of the amplifier upon which measurements are to be made are connected to these. Fig. 2 shows five circuits which may be obtained with this device and it also indicates the positions of the two key switches for each circuit.

Circuit No. 1 (Fig. 2) is the shunt-fed type with the loud speaker monitoring connection and is obtained by throwing one switch to the "Choke" position and the other to the "Monitor" position. Notice that there are 100,000 ohms in series with the loud speaker, thus preventing the loud speaker circuit from producing an appreciable effect on the load of the amplifier under measurement, since the load resistance never exceeds the value of 10,000 ohms and is usually around 4000 ohms. It is obvious from Fig. 2 how the other circuits are obtained and it is only necessary to name the circuits. Circuit No. 2 is the series circuit with monitoring connection; Nos. 3 and 4 are, respectively,

## Voltmeter Errors

ERRORS DUE TO MULTIPLIER RESISTOR		
Multiplier Ratios		Per Cent.
Nominal	True	Error
1	1	0
2	2.001	0.05
5	4.98	0.4
10	10.01	0.1
20	19.90	0.5
50	49.7	0.6
100	99.8	0.2
200	199.0	0.5

FREQUENCY ERRORS		
(Multiplier Tap 1. Input held at 0.9 volt)		
Frequency in Cycles	Meter Reading	Per Cent. Error
30	0.875	2.8
60	0.892	0.9
80	0.897	0.33
100	0.900	0.00
200	0.901	0.11
500	0.902	0.22
1000	0.905	0.44
2000	0.905	0.44
5000	0.905	0.44
7000	0.905	0.44
10000	0.900	0.00

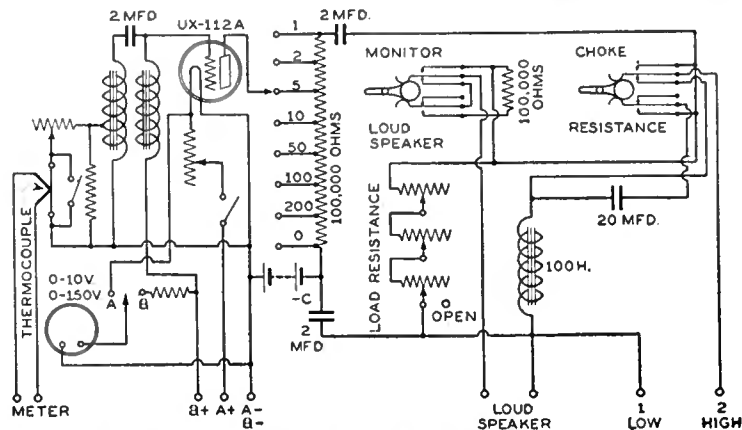

Fig. 1—Circuit of A.F. voltmeter and loading device.

## PART II

### *A Description of the General Electric A.F. Voltmeter Used in Connection With the Generator Equipment Described Last Month. Part III Will Consider the Attenuator.*

the shunt and series connections but with a loud speaker instead of a resistance as the load; and No. 5 is the calibrating or cut-out circuit. With circuit No. 5 all parts of the loading device are cut out and the voltmeter terminals (1 and 2) are connected directly to the high and low binding posts of the loading device. With this circuit calibrations of the voltmeter can be made, or voltage determinations effected with the voltmeter operating independently of the loading device.

The middle panel contains nothing but the plate battery of the voltmeter tube. The six-volt filament battery is external and is connected by a cable.

#### The Voltmeter Panel

The top panel contains all the units which constitute the voltmeter, with the exception of the indicator. This is a microammeter connected to the voltmeter by a cable.

The voltmeter proper consists of three parts; an amplifier, a multiplier, and an indicator. The amplifier is a single tube whose bias voltage, plate-load impedance, and plate voltage are so related that it operates as class "A" or linearly. In other words, conditions have been fixed so that when an alternating voltage is impressed on the grid of the tube there appears in the plate circuit a current whose shape is identical with that of the impressed voltage and the ratio of whose amplitude with respect to that of the impressed voltage remains constant as the amplitude of the voltage is changed. Now if there be placed in the plate circuit a device that will measure the effective value of this current, and if the proportionality factor between the current and the impressed grid voltage be known, then the effective value of the grid voltage is easily determinable. For this device, a thermocouple is employed. It is connected to the plate circuit through a transformer so designed that the proper value of impedance is introduced in the plate circuit to make the tube operate as a linear amplifier. The circuit diagram (Fig. 1) shows a switch connected across the heater of the couple. This is for protecting the heater from excessive currents that may exist while adjustments are being made during a series of measurements.

The voltmeter indicator,

a microammeter, is connected to the junction of the thermocouple. The scale of this meter has been marked in terms of volts; the full-scale mark is 1 volt and the lowest 0.2 volt.

A range of 0.2 to 1.0 volt is not sufficient to endow the voltmeter with any great amount of usefulness in amplifier measurements so there has been provided a multiplier with which the range has been extended to 200 volts. This is a resistor provided with a number of taps which are brought out to the contact buttons of a switch. The voltage to be meas-

ured is impressed across the entire resistor and by means of the switch the grid of the voltmeter tube is connected to that part of the resistor across which there exists a potential of not more than one volt. The taps have been calibrated so the ratio of the voltage across the whole resistor to that across the tap is known. Therefore, to determine the value of the voltage impressed across the resistor it is merely necessary to multiply the scale reading of the indicating meter by the value of this ratio. To build a satisfactory multiplier required very careful design. Its total resistance (100,000 ohms) has to be high enough so that it does not affect the circuits to which it may be connected. It must not possess either inductance or capacity, otherwise its tap ratios would be subject to variations with changes in the frequency of the impressed voltage. The multiplier as finally developed fulfilled these conditions in a very satisfactory manner. The tap ratios have been adjusted to the values of 1, 2, 5, 10, 20, 50, 100, and 200. These give a nice overlapping of readings on the meter so that when going from one tap to the next readings at the extreme ends of the meter scale are avoided. The zero tap is simply a safety position. When the switch is on this tap the

grid of the tube is short circuited and cannot be subjected to excessive voltages.

There have been included in this article data by which the magnitude of the various errors of the voltmeter can be judged. In service, the greatest errors arise from low plate voltage. Therefore the instrument is equipped with a double-scale voltmeter and two-position switch with which both the filament and plate voltages can be checked. The plate battery is made up of large units and will supply energy for a long period of time before replacement is necessary.

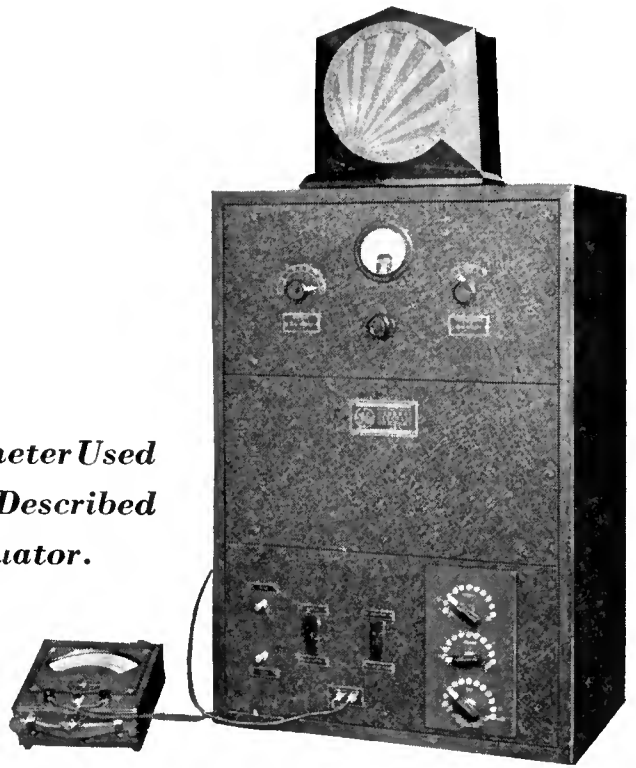

External appearance of the audio-frequency voltmeter.

#### Voltmeter Errors

INDICATOR SCALE ERRORS  
(Frequency of Voltage 100 Cycles)

Input Voltage	Scale Reading	Per Cent. Error
1.0	1.0	0.00
0.9	0.9	0.00
0.8	0.802	0.25
0.7	0.701	0.11
0.6	0.600	0.00
0.5	0.501	0.20
0.4	0.40	0.00
0.3	0.30	0.00
0.2	0.20	0.00

ERRORS DUE TO FILAMENT AND PLATE VOLTAGE VARIATIONS

Filament Voltage	Meter Reading	Per Cent. Error
4.5	0.899	0.11
5.0	0.900	0.00
5.5	0.897	0.33

Plate Voltage	Meter Reading	Per Cent. Error
123	0.82	9.0
135.5	0.90	0.0
147.5	0.955	6.0

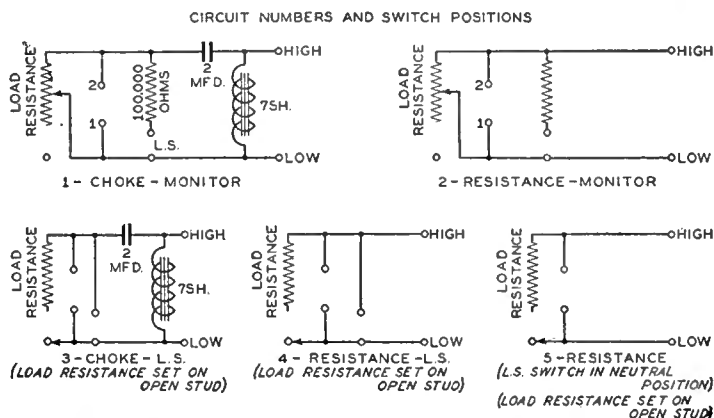

Fig. 2—Circuits obtainable with loading device.

# MEASUREMENTS ON BAND-PASS FILTER CIRCUITS

By **W. T. COCKING**

Radio Engineer, The Receptite Co., London.

Mr. Cocking, an English engineer whose writings have frequently appeared in foreign publications, presents in this article the results of some quantitative measurements on band-pass filters with various types of coupling. Although similar arrangements have been thoroughly analyzed mathematically there has been an unfortunate lack here and abroad of definite laboratory data. An article dealing with the mathematical considerations in the design of band-pass filter circuits was published in February, 1930, RADIO BROADCAST, pages 212-214.

IN MOST present-day sets the tuning is carried out by a number of cascade tuned circuits, and, although it is easy to obtain very high selectivity in this way, it is not possible to obtain good fidelity as well, unless a prohibitively large number of such circuits are used.

The band-pass filter, either alone or in conjunction with a number of cascade tuned circuits, offers a solution of the problem, for, when its components have suitable characteristics it gives high values of selectivity without serious suppression of sidebands.

In this article consideration will be given chiefly to the capacitatively coupled filter, as it is usually far superior to the inductively coupled filter. Fig. 5 (A and B) shows two different ways of obtaining inductive coupling, and (C) the usual connections for a capacitatively coupled filter.

Provided that the values of the components are suitably chosen, the results with both types of inductive coupling are absolutely identical; and they may be calculated from the same formula, equation (1) below, and this equation is also applicable for capacity coupling. It is accurate only when both primary and secondary circuits are identical; that is, the total primary circuit inductance must be equal to the total secondary circuit capacity, the total primary circuit ca-

## Some Definite Quantitative Figures on Capacitatively and Inductively Coupled Filter Circuits. Band Width as a Function of Circuit Constants. Characteristic Curves With Typical Circuit Arrangements.

capacity must be equal to the total secondary circuit capacity, and the effective, r.f. resistance of both circuits must be the same.

$$e/E = \frac{-X/\omega C}{\sqrt{[R^2 + X^2 - (\omega L - 1/\omega C)^2] + 4R^2(\omega L - 1/\omega C)^2}} \quad (1)$$

R = effective r.f. resistance in ohms of coil, when connected in circuit.

L = total inductance in henries of primary circuit and also of secondary circuit, since both are identical.

C = total capacity of primary circuit in farads and also of secondary circuit, since both are identical.

E = voltage induced in series with primary circuit.

e = voltage developed across secondary tuning condenser.

c/E = gain of circuit.

X = reactance of coupling component,

=  $\omega M$  for mutual inductance coupling,

=  $\omega L$  for inductive coupling,

=  $-\frac{1}{\omega C}$  for capacitive coupling.

At the frequency at which  $\omega L = 1/\omega C$  the formula reduces to—

$$e/E = \frac{-X/\omega C}{R^2 + X^2} \quad (2)$$

and it is obvious that the quantity  $e/E$  is greatest when—

$$R = X \quad (3)$$

Substituting, we get—

$$e/E = \frac{R/\omega C}{2R^2} = \frac{1/\omega C}{2R} \quad (4)$$

But for an ordinary series-tuned circuit—

$$e/E = \frac{1/\omega C}{R} \quad (5)$$

Hence the efficiency of the band-pass filter, with optimum coupling, is exactly

one-half of that for the ordinary series-tuned resonant circuit.

The usual simple formulas, depending upon the coefficient of coupling,  $k$ , for calculating the frequencies of the two peaks in the tuning curve of a filter are inaccurate, since they neglect the effect of the coil resistance. The peaks occur approximately at the two frequencies for which—

$$R^2 + X^2 = (\omega L - 1/\omega C)^2 \quad (6)$$

but if R is high, the term  $4R^2(\omega L - 1/\omega C)^2$  in the denominator of equation (1) appreciably affects the peak frequencies, in some cases to such an extent that the curve becomes single peaked.

At any one frequency it will be seen that capacity coupling gives exactly the same results as inductive, since at that one frequency the reactance of the coupling condenser is the same as that of the coupling inductance. The negative sign for capacity reactance makes no difference to the numerical result, for wherever X occurs in the denominator of equation (1) it is always squared. The change of sign in the numerator merely indicates that the output voltages from the filter are in opposite phase in the two cases.

### Capacitive vs Inductive

The difference between the two methods of coupling is important in the practical case, where a wide band of frequencies must be covered with a fixed value for the coupling component. It has been shown above, equation (3), that for the optimum coupling the reactance of the coupling

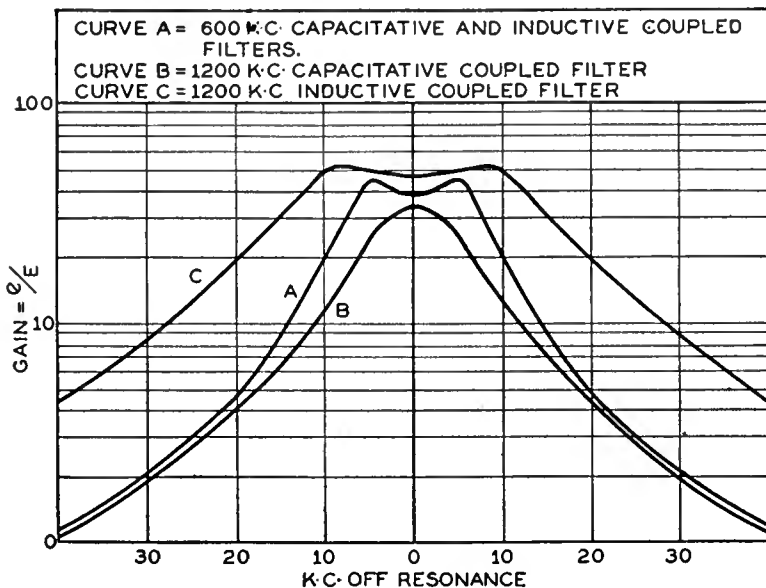

Fig. 1

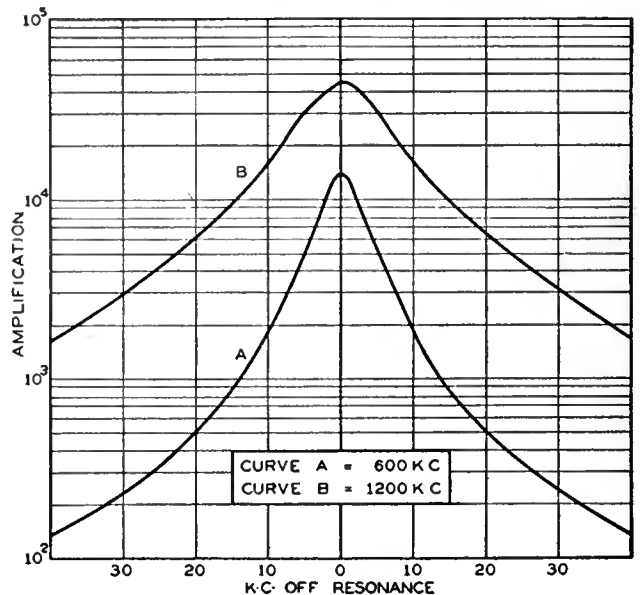

Fig. 2

component must be equal to the r.f. resistance of the coil. Now the latter, with the usual design of coils, varies in a manner roughly proportional to frequency; but the reactance of the coupling inductance is also proportional to frequency. Therefore, the optimum coupling can be maintained over a wide band of frequencies. If capacity coupling be used, however, this is impossible, for the reactance of a condenser is inversely proportional to frequency. It can be seen, therefore, that when it is desired to maintain optimum coupling over the whole tuning range of a receiver, there is no alternative to inductive coupling.

In most cases, however, it is desirable that the coupling should be greater than the optimum, which always gives a single-peaked tuning curve. With a greater value of coupling a double-peaked curve is obtained, and this can be used to compensate the usual loss of sidebands in following cascade tuned circuits. If the peaks are arranged to occur at frequencies 10 kc. apart, audible notes of 5000 cycles will be reproduced at greater strength than notes of 50 cycles; and when this is done, it is obviously desirable that the peaks should occur at the same distance apart over the whole tuning range of the receiver. This, however, is usually impossible.

In what follows it is assumed that tuning is carried out by means of variable condensers; it is not applicable to the rare cases where variometers, or a combination of variometers and variable condensers, are used.

### Band Width

At whatever frequency  $\omega L = 1/\omega c$ , at a frequency 5 kc. different from this the value of  $\omega L - 1/\omega c$  remains approximately constant; consequently, the quantity  $R^2 + X^2$  of equation (6) must also be constant in value over the whole tuning range of the receiver, if the band width is to remain constant. It will be seen that with inductive coupling this quantity is much greater at high than at low frequencies. Neglecting the effect of the resistance, when the two peaks are 10 kc. apart at a frequency of 600 kc. they will be 20 kc. apart at 1200 kc.; the increased r.f. resistance at high frequencies, which always occurs in practice, increases this variation in band width.

With capacity coupling, however, the case is exactly opposite. Neglecting the resistance, the band width at 600 kc. is double that at 1200 kc.; but in this case, the effect of the resistance is to reduce the

variation in band width. The coupling reactance is smallest when the resistance is greatest, and *vice versa*; consequently, the value of  $R^2 + X^2$  tends to remain constant. Indeed, by suitable design of the coils it is possible to make it quite constant, but this is not desirable, since the necessary increase in r.f. resistance at the higher frequencies would make the circuit very unselective. It is quite possible, however, to affect a compromise.

### Coupling Variation

When a capacitatively coupled filter is used, however, the coupling does not remain constant; it is considerably less at high frequencies than at low, and this can be used to compensate the low selectivity of both primary and secondary circuits at high frequencies. It is quite possible to design a circuit which will give constant selectivity over the entire broadcast band

Table II—Characteristics of English A.C. Screen-Grid Tubes

Type	Max. Plate Voltage	Screen Voltage	Grid-plate Capacity (mmfd.)	Plate Resistance	Amplification Factor	Mutual Conductance
Mazda AC/SG	150	60	0.005	800,000	1200	1.5
Mullard s 4v.	150	70	—	1,330,000	1000	0.75
Cossor MSG-41	150	60	—	200,000	400	2.0
Marconi s.8	150	80	0.014	200,000	160	0.8
Marconi MS 4	150	70	0.0045	500,000	550	1.1

All the above, with the exception of the Marconi s.8 tube, are of the indirectly heated cathode type, with heaters requiring a current of one ampere at four volts; they are fitted to the new English five-pin base. The s.8 tube is of the directly heated type with a filament requiring 0.8 ampere at 0.8 volt; it is fitted to the four-pin base.

From this it would seem that the only difference between capacitive and inductive coupling is that the variation of band width with frequency is less with the former. There is, however, another difference, and this also is due to the difference in the variation of reactance of the coupling components. It is well known that the ordinary tuned circuit is

of frequencies, or even one which is more selective at the higher frequencies.

In order fully to appreciate the differences between capacitive and inductive filter circuits, it is necessary to compare the resonance curves at different frequencies. In Fig. 1 are shown three curves; A is for a frequency of 600 kc. and is for both inductive and capacitive filters,

B and C are for a frequency of 1200 kc. and are for capacity and inductance coupling, respectively. For both filters the coil inductance was 240 mh., the r.f. resistance at 600 kc. was 10 ohms, and at 1200 kc. was 20 ohms. The coupling inductance in the inductive filter had a value of 4.7 mh., and the condenser in the capacitatively coupled filter had a capacity of 0.015 mfd. —values which give the same degree of coupling at 600 kc. The

essential figures for selectivity, gain, and sideband variation are given in Table 1.

### Greater Selectivity

The immense superiority of capacity coupling is at once evident; both filters give the same results at 600 kc., but at the higher frequency, the selectivity with capacity coupling is nearly three times that with inductive, being 30 instead of 10.5. At 600 kc. it is 33 with both circuits. These figures for selectivity are obtained by dividing the filter output voltage at resonance by the output voltage at a frequency 40 kc. different from resonance, the input voltage being the same for both frequencies. This method of expressing the selectivity is used throughout this article. The amount of sideband cutting is called the sideband variation, and is expressed as a loss in percentage. With band-pass filters it is sometimes a high-note loss and sometimes a high-note accentuation; the upper sideband limit is taken as 5000 cycles. The ratio  $e/E$  has been defined earlier, but it must be remembered that it is *not* the actual amplification from the antenna to the grid of the first r.f. tube; the actual amplification depends upon the method and degree of coupling to the antenna, as well as the antenna constants.

Returning to the consideration of Fig. 1. It can be seen that the amplification is

Table I—Essential Figures for Selectivity, Gain, and Sideband Variation

Description	Frequency	Amplification	Selectivity	Sideband Variation per cent.
Inductive filter	600 kc.	39	33	15
M = 4.7 mh.	1,200 kc.	47	10.5	6
Capacitive filter	600 kc.	39	33	15
$C_1 = 0.015$ mfd.	1,200 kc.	33	30	26
Amplifier, two Mazda a.c./SG tubes in tuned plate circuit	600 kc.	14,000	112	61
	1,200 kc.	43,000	25	29
Amplifier and Inductive filter	600 kc.	540,000	3,700	54
	1,200 kc.	2,021,000	262	24
Amplifier and Capacitive filter	600 kc.	540,000	3,700	54
	1,200 kc.	1,435,000	736	47
Capacity filter in untuned circuit, capacity filter in plate of first a.c. SG tube, and tuned plate for second r.f. amplifier. Five tuned circuits in all	600 kc.	234,000	11,600	15
	1,200 kc.	604,000	4,360	54

less selective at high frequencies than at low, and this is partly due to the increased coil resistance. It is also well known that with any filter circuit a decrease in the coupling increases the selectivity. When an inductively coupled filter is used with ordinary coils, the coupling remains constant at all frequencies; both primary and secondary circuits are less selective at high than at low frequencies, and, since the coupling is constant, the variation in selectivity is accentuated. It is about the same as that with two cascade tuned circuits.

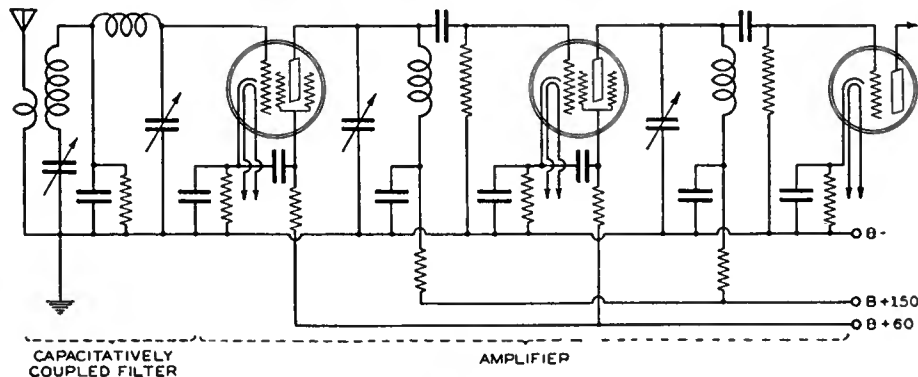

Fig. 3



nearly the same with all three curves, being slightly greater with inductive coupling at the higher frequency. The sideband variation, however, is very different; at 600 kc. it is 15 per cent., and is in the form of a high-note accentuation. At 1200 kc., with inductive coupling it is only 6 per cent., but with capacity coupling there is a high-note loss of 30 per cent. This difference in the amount of sideband variation at different frequencies is not the disadvantage it may at first appear to be; as will be shown later, when considering the applications of the filter to a tuned r.f. amplifier, it is rather an advantage than otherwise.

### Coupling Tubes

The band-pass filter may be used with very similar results as a means of coupling two tubes in a r.f. amplifier. It is usually

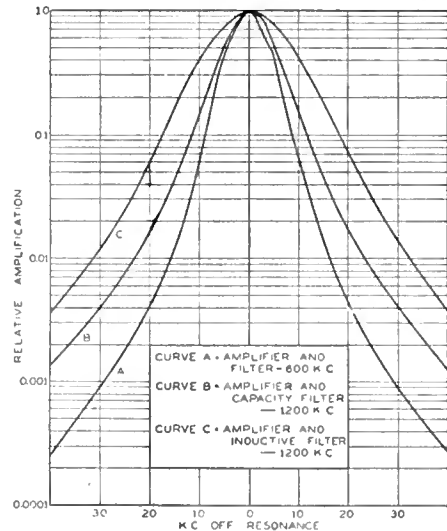

Fig. 4

unnecessary to do this, however, as it is but rarely that more than one filter is needed in a receiver; and if only one filter is used, it should always be included in the antenna circuit, owing to the greater freedom from "cross-talk" which can then be obtained. The formula necessary for calculating the amplification given by a tube with a filter in the plate circuit is given below, where the symbols have the same meanings as before—

$$A = \frac{\mu^2 X^2 C^2}{\sqrt{\left[ R_p \left( R^2 + X^2 - \left( \omega L - \frac{1}{\omega C} \right)^2 \right) + \frac{L R}{C} \right]^2 + \left[ \left( \omega L - \frac{1}{\omega C} \right) (2 R R_p + \frac{L}{C}) - \frac{X^2}{\omega C} \right]^2}} \quad (7)$$

A = amplification  
 $R_p$  = tube plate resistance  
 $\mu$  = amplification factor

At the frequency at which  $\omega L = 1/\omega C$  this reduces to

$$A = \frac{\mu^2 X^2 C^2}{R_p \left( R^2 + X^2 \right) + \frac{L R}{C}} \quad (8)$$

since  $X^2/\omega C$  in the right-hand bracket of the denominator is usually negligible in comparison with the other terms.

When the tube has a plate resistance greater than about 500,000 ohms, it is sufficiently accurate for most purposes to calculate the shape of the tuning curve from equation (1), and the amplification at resonance from equation (8). The results will show the selectivity and sideband variation as being slightly higher than is actually the case, but the error is usually inappreciable. Of course, if the tube has a low plate resistance the correct formula (7) must be used, and this will always give correct results.

### Plate-Circuit Filter

The remarks made earlier in this article on the respective merits of inductive and capacitive couplings apply with equal force to the plate-circuit filter. The only difference in the results is due to the damping exerted by the tube's plate resistance on the primary circuit of the filter. If this resistance is high, as it usually is with good modern screen-grid tubes, the difference is very small.

With modern screen-grid tubes, however, sufficient r.f. amplification for most purposes can be obtained with two stages, with the usual methods of coupling the tubes. This amplification is sufficient to permit the use of one filter, but it is not usually great enough if two filters are used; since the loss of amplification in each filter must be at least 50 per cent. The curves of Fig. 2, A and B, show the amplification and selectivity of a particular r.f. amplifier at frequencies of 600 kc. and 1200 kc., respectively. The amplifier, the skeleton circuit of which is given in Fig. 3., consisted of two Mazda AC/SG screen-grid tubes coupled by the tuned plate circuit, with coils having an inductance of 210 mh. and a r.f. resistance at 600 kc. of 10 ohms, and at 1200 kc. of 20 ohms. The tuned plate circuit was adopted because, owing to the high plate resistance of these tubes, no greater amplification could be attained by the use of a transformer nor could the selectivity be increased to any great extent. In addition, the tuned plate circuit allows of very simple switching arrangements being used to change from one wave range to another. This is a very important point in designing receivers for use in England, for every set must be able to receive not only on the normal waveband of 200-550 meters, but on the 1000-2000-meter waveband also. The characteristics of English a.c. screen-grid tubes are given in Table II.

### Amplifier Characteristics

It will be seen that the amplification given by this amplifier is very high; at 1200 kc. it is 200 per stage, and this with perfect stability. Now it is obvious that if this amplifier were preceded by a normal single tuned antenna circuit, it would result in poor selectivity at the higher fre-

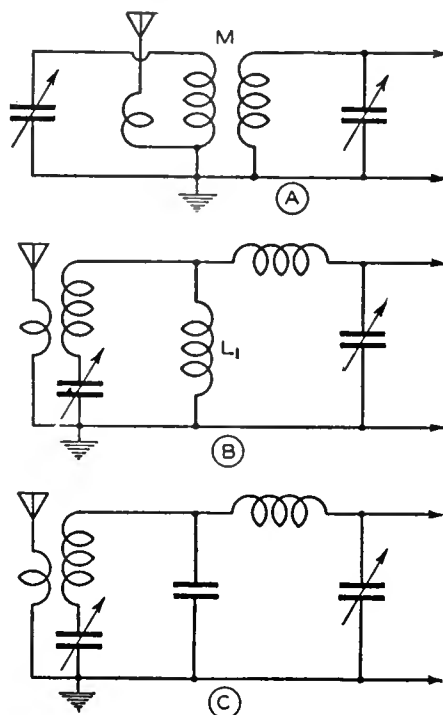

Fig. 5

quencies, for each of the three tuned circuits would give greater selectivity at the low frequencies. In addition, the sideband loss would be far too high, for with only two circuits it is 60 per cent. at 600 kc. The results, when the amplifier is preceded by a filter, however, can be seen from Fig. 4, in which curve A is for a frequency of 600 kc., and for either capacity or inductive coupling in the filter; curve B shows the results with capacity coupling at 1200 kc., and curve C for an inductively coupled filter at the same frequency. It is included so that a comparison can be made between inductive and capacitive coupling. The values of the coupling components are the same as those mentioned earlier. The input voltage for these curves is such that the out-

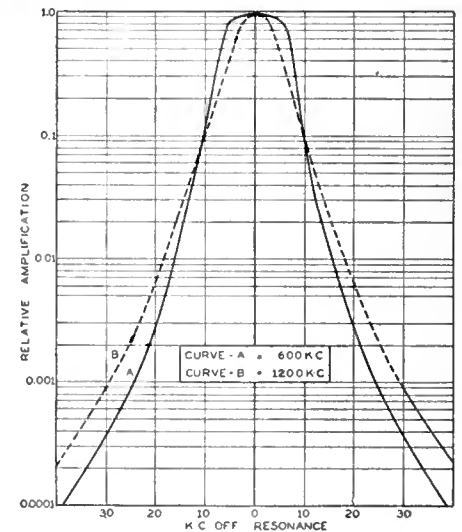

Fig. 6

put voltages at resonance are the same for all three; in this way the differences in selectivity and sideband variation may be seen readily. The figures for amplification are given in Table I, but it must be remembered that these figures show the amplification of the voltage induced in series with the primary circuit of the filter, not the voltage in the antenna.

### Selectivity Variation

The superiority of capacity coupling is even more obvious in these curves than it is in those for the filter alone, for the poor selectivity of inductive coupling at the higher frequencies is accentuated by the same defect in the amplifier. With capacity coupling the selectivity varies in a 5-1 ratio between 1200 kc. and 600 kc., but with inductive coupling this ratio is 14-1. Not only this, but an advantage is gained in fidelity also. The high-note loss at 600 kc. is 51 per cent. with both methods of coupling; at 1200 kc. it is only 25 per cent. with inductive coupling, and 47 per cent. with capacity coupling. It is decidedly an advantage that the loss should remain constant over the whole tuning range of the receiver, for it makes it possible to compensate it by increased amplification of the upper audible frequencies in the a.f. amplifier. Although, with the loss of 50 per cent. given by this particular arrangement, it is rather doubtful whether any great increase in fidelity would result from such compensation, as the ear is very tolerant of a high-note loss. It is probable that a loss of this order is unnoticeable by the average ear.

The curves of Fig. 6 show the results to be expected from the same amplifier, but with a capacitatively coupled filter substituted for one of the tuned plate circuits.

(Continued on page 349)

# THE INVESTOR LOOKS AT RADIO

By **BERKELEY A. CATER**

Chief Statistician, Blumenthal Brothers  
Members, New York Stock Exchange

*The First of a Series of Articles Considering the Speculative and Investment Values of Radio Stocks. This Installment Considers Conditions in General; The Next Article Will Analyze the Position of R.C.A.*

IT IS PROBABLE that more money has been made and possible that more has been lost in radio than in any other development in this generation. Surely, any industry which has so profoundly affected so many people is worthy of our brief attention.

The growth of the industry has been truly fantastic and has naturally aroused public interest not only in actual receiving apparatus, but also in securities of radio manufacturers. In many cases large profits were realized, both because of the growth of the industry and the rapidly rising stock market, but in almost as many cases losses were equally great. The unknown element of mystery in radio was indirectly responsible for successful pool operations in many radio stocks, for it is well-known that such operations are seldom successful in stocks lacking an air of mystery, as pool operators work on public fancy rather than facts.

## *Investor vs. Speculator*

If we were to attempt to survey the situation in radio strictly from the investor's point of view we could not proceed much further, for few, if any, of the common stocks of radio companies are entitled to true investment ratings. Admitting that in many cases the difference between investment and speculation is not clearly definable, we believe that to enjoy an investment rating a common stock must (a) participate in the earnings of a stable and necessary industry, (b) pay a reasonable dividend in relation to earnings and market value, and (c) have paid that dividend for a number of years, in depression and prosperity, thus indicating a substantial reserve. A few radio stocks will undoubtedly attain investment rating within a few years; and a few are now reasonably attractive as a speculation for long-term holding. A modification of our title to "The Speculator Looks at Radio" would thus seem necessary. As we are not interested at the moment in any particular company or the advantages of owning a particular set, we shall limit the discussion to the financial condition of the industry as a whole and its prospects for the future.

Although the development of radio in this country has been phenomenal, it has been typical of the extremes of American commercial enterprise, both enjoying the advantages and suffering the disadvantages of our aggressive manufacturing and sales policies. The industry has grown so rapidly that it has suffered from lack of balance and at the moment cannot be said to be in a thoroughly healthy condition. This is in spite of the fact that radio broadcasting and receiving have reached a very high state of perfection in this country and are being improved to fulfill the best artistic and commercial requirements.

Of the 24,000,000 homes in the United States, 12,000,000 or more are believed to be equipped with radio receiving sets. Of the remaining 12,000,000, several million will never be able to afford sets and a small portion will never want them. As the sale of radios in 1929 was estimated at from 3,000,000 to 3,500,000 sets, it is obvious that at this rate of production every prospective purchaser could be supplied within a few years. This growth in the manufacture of receiving apparatus has been far more rapid than was healthy and may be compared to an over-grown child that has not yet reached its strength.

Frequently we are told that without the drastic decline in the stock market, radio sales would have continued to advance as rapidly as in the past, but if we consider the facts as they are, we shall arrive at a less favorable conclusion. It is true that the break in the market did seriously affect sales in November, as compared with October. However, recovery was noticeable in December, largely because of the holiday trade, but it was still not sufficient to dispose of stocks on hand. It is estimated that more than 1,000,000 sets are being carried over which must before long be thrown on the market. [Sale of these sets is felt to be proceeding at a steady and satisfactory rate—*Ed.*] The beginning of this liquidation has already become apparent in some of the larger centers, where radio prices have been cut materially. Although the break in the market with its consequent loss of buying power to the average investor had some effect on radio sales, it may more truthfully be said that it revealed an unsound condition in the industry which would inevitably have become known at a later date, and probably with more unfortunate results.

## *Industry Problems*

The problems facing the industry are therefore (a) to dispose of stocks on hand without a price war, and (b) to improve receiving apparatus so materially either in reception or appearance that the replacement demand will take care of production. That this task will not be easy may be realized when we consider that the combined manufacturing facilities of all companies in the field could produce annually over 15,000,000 sets.

It is possible that the answer to the question lies in sales overseas, especially in countries where the average per capita wealth is high, but there are definite reasons why such sales cannot increase as rapidly as was the case in the domestic market. These reasons are briefly that (a) wavelengths in many countries are dissimilar to our own, necessitating a different type of apparatus, (b) delivery cannot



be made quickly, (c) American manufacturers are loath to extend credit facilities to overseas dealers, and (d) the landed cost of American sets is much higher than sets made by European manufacturers. Although exports of radio apparatus in 1929 reached a total of \$23,122,141, a gain of \$11,060,662 over 1928, the greater part of our exports went to Canada, Australia, and the more prosperous South American countries where merchandise of quality can be sold because of relatively high average wealth.

In Europe the prospects are much less hopeful, for the quality of our merchandise is not as a rule sufficiently better to warrant the extra cost.

## *A Comparison*

The radio industry may be compared in a number of respects with the automobile industry in its early stages. Of the many early manufacturers, only a few of the strongest have survived. Automobiles have apparently nearly reached a state of perfection, changes being of a non-essential nature, such as color or body design, but automobiles of necessity will wear out and must be replaced. The contrary is true of radio apparatus for, with the exception of tubes, and in some cases, batteries, there is little deterioration. Offsetting the fact that radios are much cheaper than automobiles and may reach the saturation point sooner for that reason, is the possibility of further perfection making existing apparatus practically obsolete. In this field lies the hope for the industry. Which tendency will be stronger can be answered only by the course of future events.

## *Other Weaknesses*

Not all the ills of the industry should be attributed to over-production for some companies have lacked one or more of the requisites for success, such as skilled research engineers, good advertising and merchandising policies, and strong financial backing. The market value of the stocks of some companies has been made still weaker by pool operations which in some cases appear to have received the support of the managements, and it is doubtful if any radio stocks have escaped some manipulation. The recent receiverships, of Earl

(Continued on page 345)

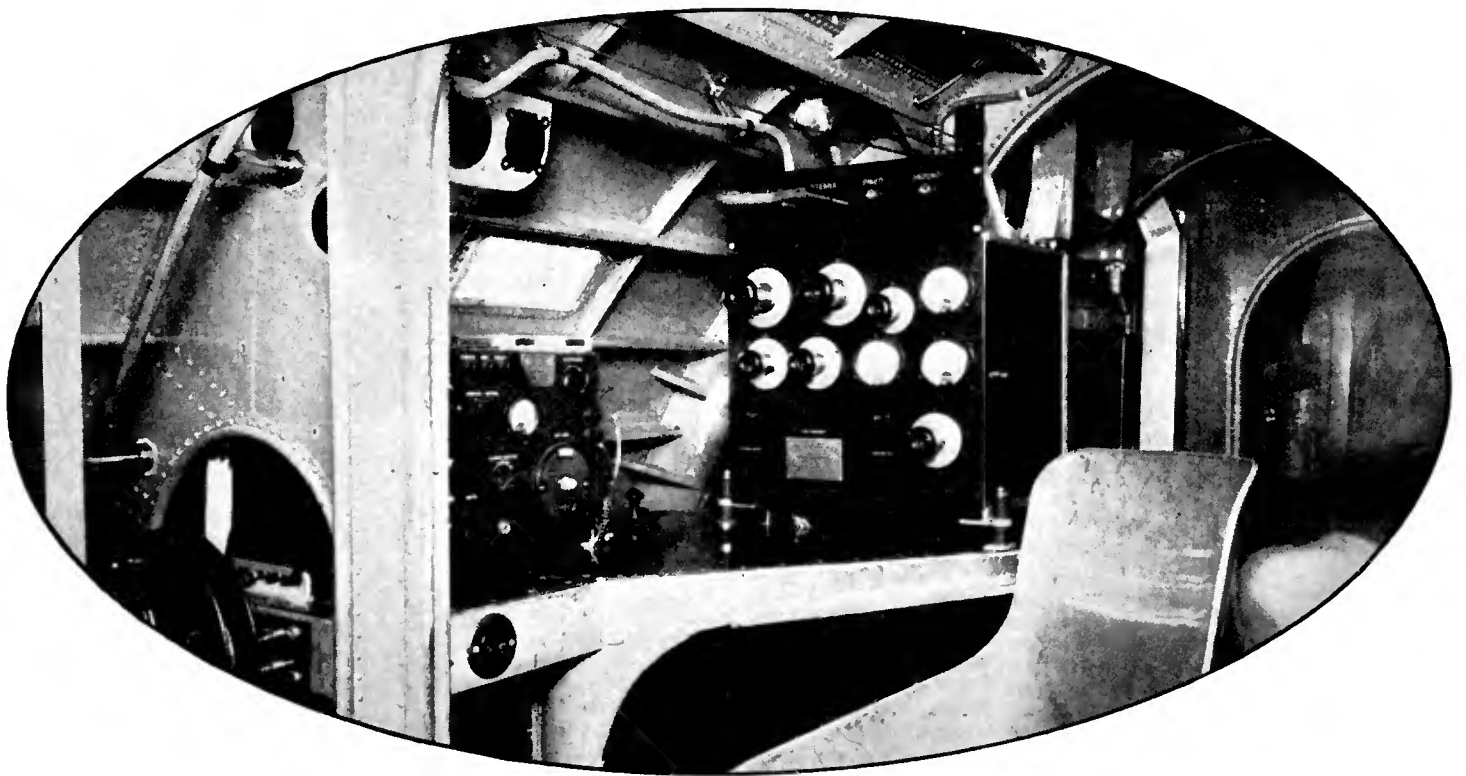

View of radio transmitting and receiving apparatus in a modern Navy airplane.

## AIRCRAFT RADIO DEVELOPMENT

### *A Summary of the Factors Influencing the Design of Aircraft Transmitters and Receivers. General Requirements of Receivers for Aircraft Use. Sensitivity, Fidelity, and Band Width Characteristics of a Typical Receiver.*

THE FIRST telephone transmission from plane to ground was accomplished in England during the summer of 1915 by Major Prince and Captain H. J. Round. A cw tube transmitter was used for this notable achievement. Since that time, radio has come to play an increasingly greater part in the development of commercial aviation.

Ignition noise has prohibited the use of highly sensitive receivers until very recently. This necessitated the use of the long, trailing-wire antenna which was unsatisfactory on account of landing problems, time involved in reeling the antenna in and out, frequency variation, losing the antenna, and other factors. Mechanical vibration and noise has made the choice of non-microphonic tubes a necessity. The problems of construction, instrument mounting, and dependability are also dependent upon the extreme amount of vibration encountered. The placement, accessibility, and servicing of the component parts must be considered. The apparatus must be simple and fool-proof, because the average pilot and mechanic are not expert radio operators and only the larger commercial planes can accommodate a special radio operator. Frequency choice is important, and depends largely upon the purpose of the equipment. Continuous communication with ground stations along standard airways must be considered. The apparatus must be able to withstand the unusual climatic, humidity, and temperature changes encountered during any kind of flight. Tuning must be accomplished with heavy gloves at times. A locking device is frequently necessary to prevent "creeping of tuning," especially for beacon work. The apparatus must be extremely light, shock-proof, and compact. The power supply should be such that the equipment can be operated during emergencies, such as a forced landing. Sufficient

By **ELMER L. BROWN**  
*Engineer, Special Equipment Division,  
 RCA-Victor Co., Inc.*

output of the receiver is necessary for operating a beacon-indicating device.

The trailing wire type of antenna, which has been used until very recently for both

the dirigible type of airship and the heavier-than-air type of craft, had several distinct advantages as well as disadvantages. Its use is confined largely to the lower frequencies, and it is comparatively satisfactory around 300 kc. It is possible with this type of antenna to communicate over compar-

atively long distances with a minimum of power. However, it is necessary to reel this antenna out when communication is desired and to reel it in when communication is finished. The maintenance cost of this type is large, and the hazards encountered when flying at low altitude make it undesirable. It is also impossible to use it when a forced landing must be made. The air resistance of this antenna increases the drag on the ship and materially reduces its speed. It is impractical for military use, as a plane cannot be stunted.

Effective shielding of ignition systems makes it possible to use receivers with a sensitivity as high as 5 microvolts per meter. Sensitivity greater than this is undesirable, as with it one is enabled to get down to the noise level with a short vertical-rod antenna. The vertical antenna is justified by its elimination of physical hazards, burdens of operation and maintenance, and a substantial reduction in beacon errors. A streamlined duralumin vertical antenna 2 or 3 meters in height, triangular and guyed to the upper wing and fuselage, has much less wind resistance than a trailing wire, and is still short enough not to interfere with putting the plane in the hangar. This type is particularly satisfactory for high-frequency work, as it is rigid enough not to cause swinging of the signals. This eliminates the use of a kite for emergency landings as was necessary with the trailing-wire type. A modified T or V type of antenna can be used successfully with larger ships and dirigibles. Almost any type of rigid structure can be used with dirigibles.

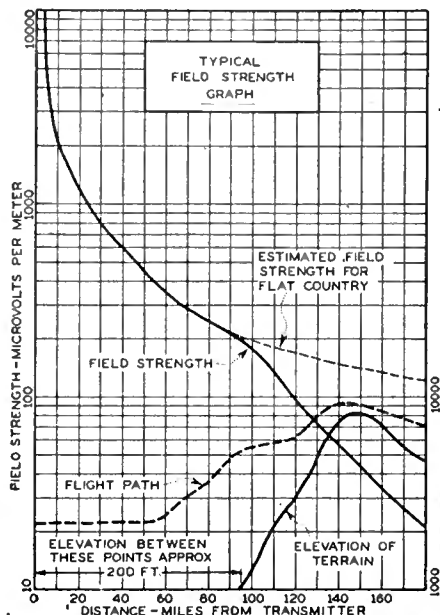

Typical aerial field-strength curve.

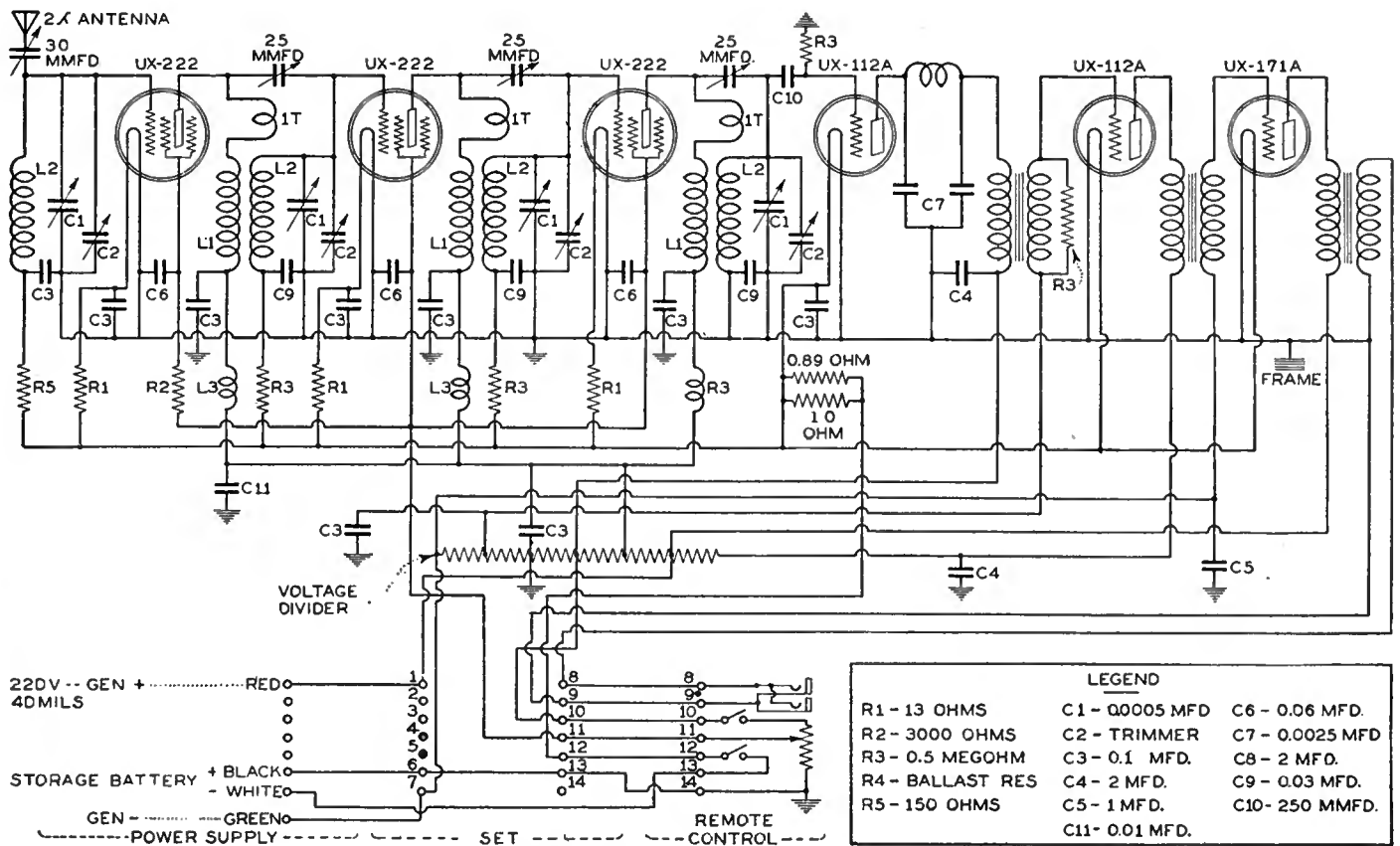

The schematic diagram of a typical air-beacon receiver

Three types of radio receivers are in general use by aircraft. These are:

- (1) Military type that is required to cover a broad band of frequencies.
- (2) The average commercial beacon and radiophone receiver required to cover the comparatively narrow band from 285 to 350 kc.
- (3) The high-frequency receiver that operates on frequencies above 1500 kc.

The first type has rather rigid specifications and usually requires the use of a specialist in operating.

The second type is a standard tuned-radio-frequency receiver, and usually consists of three tuned stages of screen-grid radio-frequency amplification, a detector, and two stages of audio-frequency amplification with sufficient output to operate a beacon-indicating device.

The third type usually consists of a regenerative receiver employing plug-in coils for the different frequency bands and sufficient a.f. amplification for easy reception above the mechanical noises.

The general requirements of a radio receiver for aircraft use are as follows:

1. Single dial control. Fixed tuning.
2. Rugged volume control. Capable of remote installation.
3. Sufficient shielding to limit signal pick-up to that of the antenna.
4. Rugged construction in order to be immune from vibration encountered.
5. Non-microphonic construction.
6. Rigid condenser plates. Wide spacing with plates of at least 0.025-inch stock is usual practise.
7. Non-microphonic tubes. Tubes of the heater type such as UX-227 and UX-224 are particularly adapted for aircraft use.

(The great demand, particularly by the aircraft industry, for a non-microphonic low-current-consumption tube has resulted in the development of the UX-864 type. This tube has approximately the same characteristics as the UX-199, except that it uses an oxide-coated filament requiring 0.250 amperes at 1.1 volts. This tube is extremely rugged, non-microphonic, and

beacon indicator, jack for phones, and necessary cable connections.

10. Of such size and dimensions which permit installation in whatever space is available.

11. Sufficient sensitivity to get down to atmospheric noise level with a 2-meter vertical-rod antenna.

12. Sufficient fidelity. Beacon signals are modulated from 40 to 120 cycles and the voice ranges from 300 to 3000 cycles.

13. Must have sufficient output to operate a beacon course-indicating instrument. Ten volts of audio frequency with a load impedance of 4000 to 7000 ohms is sufficient.

14. A fair amount of selectivity is necessary, although the problem is not yet as bad as that on the broadcast frequencies.

15. A well-designed helmet to exclude mechanical noises. Use of sponge rubber caps is satisfactory.

16. Should be satisfactory for both visual and aural beacon reception up to 150 miles with a 2-kw transmitter on the ground on the 333-kc. band, using an antenna 2 meters high on the plane, and the bonded metal members of the plane for a counterpoise.

17. The total weight, including a 5-pound duralumin antenna and a 10-pound battery, should not exceed approximately 35 pounds. The battery used for the navigating and landing lights may be used for the filament supply of the receiver.

Plate rectification with automatic grid bias is desirable when used with a visual indicator. Reversal or lack of course indications may result if the input is increased through values corresponding to the maxima of the curve into the regions of the negative slope. An automatic bias prevents this. The sensitivity and selec-

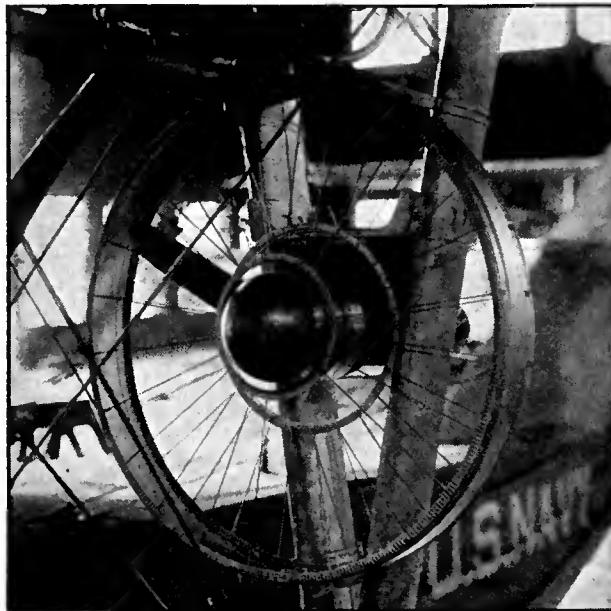

View of a wind-driven motor generator.

economical in operation.) It is understood that a complete line of low-current, low-voltage, non-microphonic tubes are being developed.

8. Accessibility or ease of servicing. The receiver mounted on a track with a locking control is quite satisfactory.

9. Dash control. This consists of volume control, on-off switch, tuning device,



tivity of the receiver are also better with plate rectification.

### The Transmitter

The type of transmitter used depends naturally upon many factors. Roughly, a radio-telephone will cover about one-third the distance of a radio-telegraph transmitter of the same power, but will weigh about 20 per cent. more. However, these figures are only relative, since range vs. weight varies considerably with equipment.

The transmitter is governed by the same requirements as the receiver in regard to rugged construction, flexible mounting of parts, accessibility, dimensions, and frequency stability. In the latter case crystal control is a great aid.

A range of at least 100 miles of consistent communication is acceptable for commercial aircraft flying in standard airways, since stations are located every 200 miles, and beacon marker stations with auxiliary equipment every 100 miles. A combined cw and radiophone transmitter seems to be the desirable thing, because few pilots have the time or patience to learn the code sufficiently for expert operation of a straight cw transmitter. As planes become larger and the pay-load question is of less importance than at present, sufficient weight may be allowed for a radiophone of sufficient power to communicate over fairly long distances.

The wind-driven generator is giving way to the more recent type which is direct coupled or geared to one of the plane motors. A voltage regulator keeps the output practically constant. These generators vary in output from 500 watts to 2 kw, and both the filament and plate supply currents are delivered by them. They are available for both a.c. and d.c. output. In some cases the high voltage delivered is 500 cycles or so.

Possibly the power supply of greatest

value lies in a separate small gas engine-driven generator. This could be used for ordinary communication service, and would be invaluable as an auxiliary. Several types have been developed, but a great deal of experimental work is still to be done in this field. A small two-cycle, two-cylinder motor of about 2 H.P. is about right for most commercial purposes.

A battery-driven dynamotor may also

ignition and mechanical noises made the cross-coil beacon necessary. This beacon consists of two coil antennas disposed in two vertical planes fixed at an angle from each other. In a simple form the two-coil system is free to be rotated about a vertical axis. When the two coils are similarly excited with a modulated radio-frequency current, signals of equal intensity will be heard on a receiving set when situated

along either one of the two vertical planes bisecting the angles between the planes of the coils. At other points, the signal intensity from each coil will be different.

A mechanical device can transmit the letter N (— ·) on one loop and the letter A (· —) on the other, and they are so interlocked that a continual buzz is heard along the equisignal zone. A deviation of from 1 to 3 degrees from the course will result in one or the other letter becoming distinctly predominant.

The advantages of this type of beacon are:

1. No zone of maximum or minimum signal strength.
2. Location of course found by the comparison of two signals.
3. A plane may be guided along a given airway without regard to wind drift.
4. When considerably off course, the beacon furnishes a definite signal allowing plane to return to former course. Valuable when plane must make detours or is forced off course.
5. Used on national airways.
6. Ordinary receiver and antenna may be used.

The disadvantages are:

1. "Plane effect" or angle of plane causes slight error.
2. "Night effect" or shifting of equisignal zone at night makes it undesirable for night flying.

(Continued on page 358)

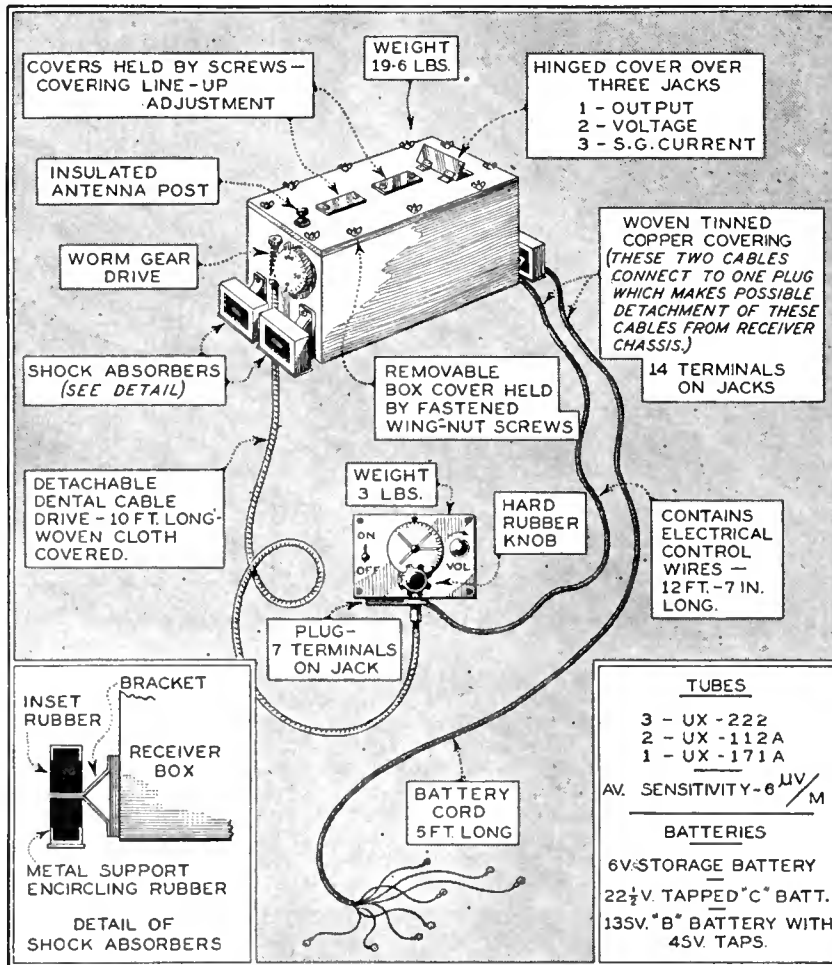

A mechanical description of aircraft beacon receiver type AR1286.

be used to advantage for an auxiliary power supply, and will furnish power as long as the lighting battery lasts.

### Frequency Choice

The standard allocated frequency band for radio beacon service is from 285 to 315 kc., and that for aircraft radio communication is from 315 to 350 kc. The design of a receiver to cover this comparatively narrow band of frequencies is comparatively easy and most commercial aircraft receivers are designed for this use.

The 500-kc. band may be used for distress or emergency signals. Frequencies around 3000 to 4000 kc. are good for fairly long-distance low-power communication and are not much affected by fading, skip-distance, directional effects, type of antenna, and other phenomena characteristic of frequencies higher than this. These frequencies will undoubtedly prove of great value in the future of aircraft radio. Frequencies as high as 11,000 kc. have been used with very good success for long-distance, low-power communication on trans-oceanic flights and expeditionary flights. However, they were naturally affected by skip-distance, etc.

### Radio Beacons

The radio beacon of to-day is as practical and perfect as the ordinary magnetic compass. High noise level caused by the

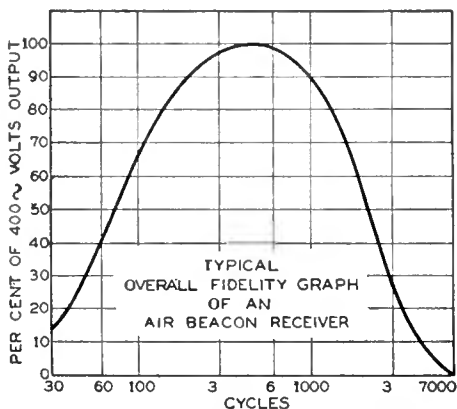

The above curve indicates the overall fidelity of the average air-beacon receiver.

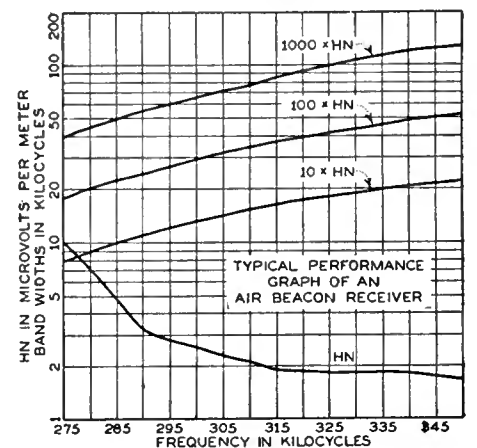

The curve "HN" gives sensitivity in microvolts per meter for 50 mW. output. The other curves give band width in kc. for inputs of 10, 100, and 1000 HN.

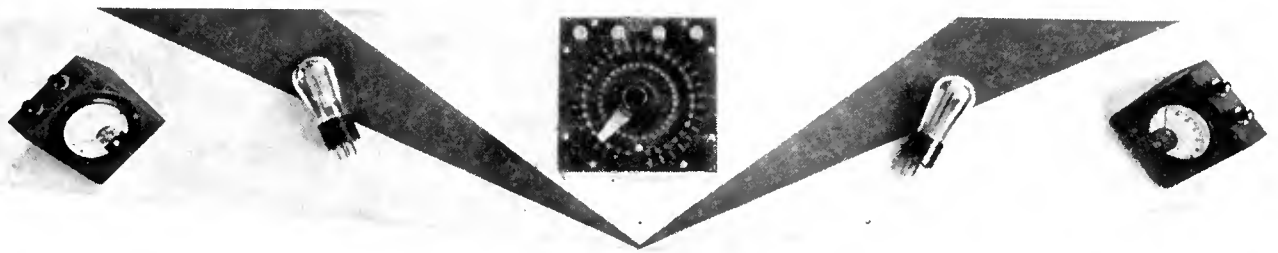

# STRAYS FROM THE LABORATORY

## Sun Spots and Radio

A correspondent questions the correlation between solar activity (sun spots) and radio reception and at the same time wonders if the steadily declining field strengths from distant stations are not due to a "saturation" or overloading of the ether. We sent these doubts and suggestions to Dr. Pickard whose speculations on the interesting questions and long continued measurements on WBBM's field strength have won him great credit. Dr. Pickard's answer is a chapter in the book of fundamental knowledge of radio. Dr. Pickard's curve (Fig. 1) shows such definite relation between solar activity and radio reception as to leave no doubt. Dr. Pickard says:

"Signal strength at night from distant stations has been on the down-grade for at least the past three years. But the correlation of this decrease with solar activity has been proven beyond any doubt, and irrespective of any hypothesis. Many thousands of reception measurements, taken systematically over periods of years, have shown such high correlation with measures of solar activity that the relation of sun and reception is as certain as the relation of moon and tide.

"But 'etheric overloading' is a harder problem. If the entirely hypothetical 'ether' really had the properties of matter, it might, of course, have definite tensile strength, and perhaps also exhibit frictional or hysteretic losses, in which case it would either break up or heat under severe loading. But the majority of modern physicists do not believe there is an 'ether'. Instead, our present-day view is that what we call electromagnetic waves are merely energy quanta shooting bullet-wise across empty space. According to this view overloading has no physical meaning; how can we overload a void by merely projecting more quanta through it?"

"This reasoning may not be convincing to everyone, particularly those who still

cling to their 'ether'. So, avoiding all assumptions as to the existence of properties of the medium, let me present some evidence from the experimental side. First, consider the well-known fact that a station hundreds or thousands of kilometers distant can be well received even

goes through unchanged, save for the slight Einsteinian bending caused by the gravitational field."

## British Heater Tubes

An article in January 8, 1930, *Wireless World* entitled "A New Method of Detection," while somewhat misleading in title, since no new method of detection is described, gives some interesting data on English heater-type tubes. American set engineers have long wondered at the high values of mutual conductance secured by foreign tube manufacturers, which cannot all be laid to the fact that tubes "over there" are measured at zero grid bias and not under operating conditions.

The Marconi and Osram MHL4 is called a general-purpose tube, has a plate resistance of 3000 ohms, and an amplification factor of 6. At a grid bias of 23 and a plate potential of 200 volts the plate current is 19.5 milliamperes. It will turn out about 750 milliwatts.

The MHL4 has a resistance of 8000 ohms and a  $\mu$  of 16. Its resistance is sufficiently low that it may be used with a transformer output with about double the voltage amplification secured from our heater-type general-purpose tube.

Both of these tubes are very good, having mutual conductances of the order of 2000 micromhos (at zero grid bias). The heater consumes 1.0 ampere at 4 volts.

The MHL4 makes a good grid-circuit detector as the curve in Fig. 2 shows. With an r.m.s. input signal of about 2.75 volts it will deliver about 8 volts of a.f. at 50 per cent. modulation. The circuit constants are given on the curve.

## A Correction

On page 223 of the February issue curves were given showing the selectivity and sensitivity characteristics of Radiola 21 and 22 receivers. Unfortunately the

(Continued on page 349)

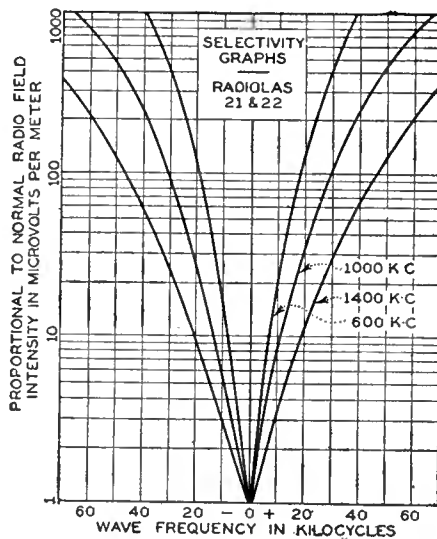

Fig. 3

directly under the antenna of an operating high-powered transmitter. Measurements of the field strength of the distant station show no change when the local transmitter is thrown on and off. Yet, the field immediately around a high-powered transmitter is enormous as compared with that from the distant station, and if there were any such thing as overloading, such a test would show its presence.

"But far more severe tests have been made. A pair of metal terminals may be placed in a tube exhausted to the limit of modern vacuum technique, and a field of the order of a million volts per centimeter can be impressed without breaking down the intervening space. In fact, when such a tube finally does pass current, it is because electrons are bodily torn from the metal terminals; not because the space between is in any way overloaded. Recently very great magnetic fields, of the order of a million or more gauss, have been produced by heavy transient currents in small coils. But the space traversed by this intense magnetic field shows no sign of distress. Such electric and magnetic fields, viewed as strains or loads upon a medium, are millions of millions of times greater than the average loading produced by the radio stations of the world, and still nothing happens.

"Finally, consider the space just beyond the sun's surface, traversed by the intense radiation from the photosphere and by the solar gravitational and magnetic fields as well. Heavily loaded as is this space by both waves and fields, during a solar eclipse we find the light from a distant star

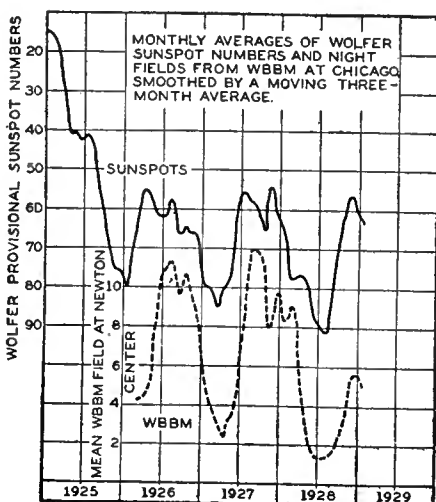

Fig. 1

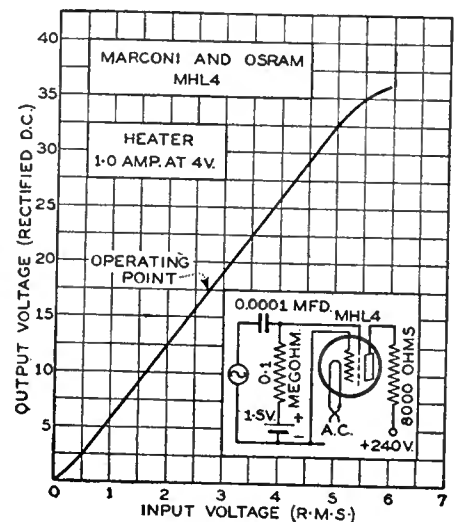
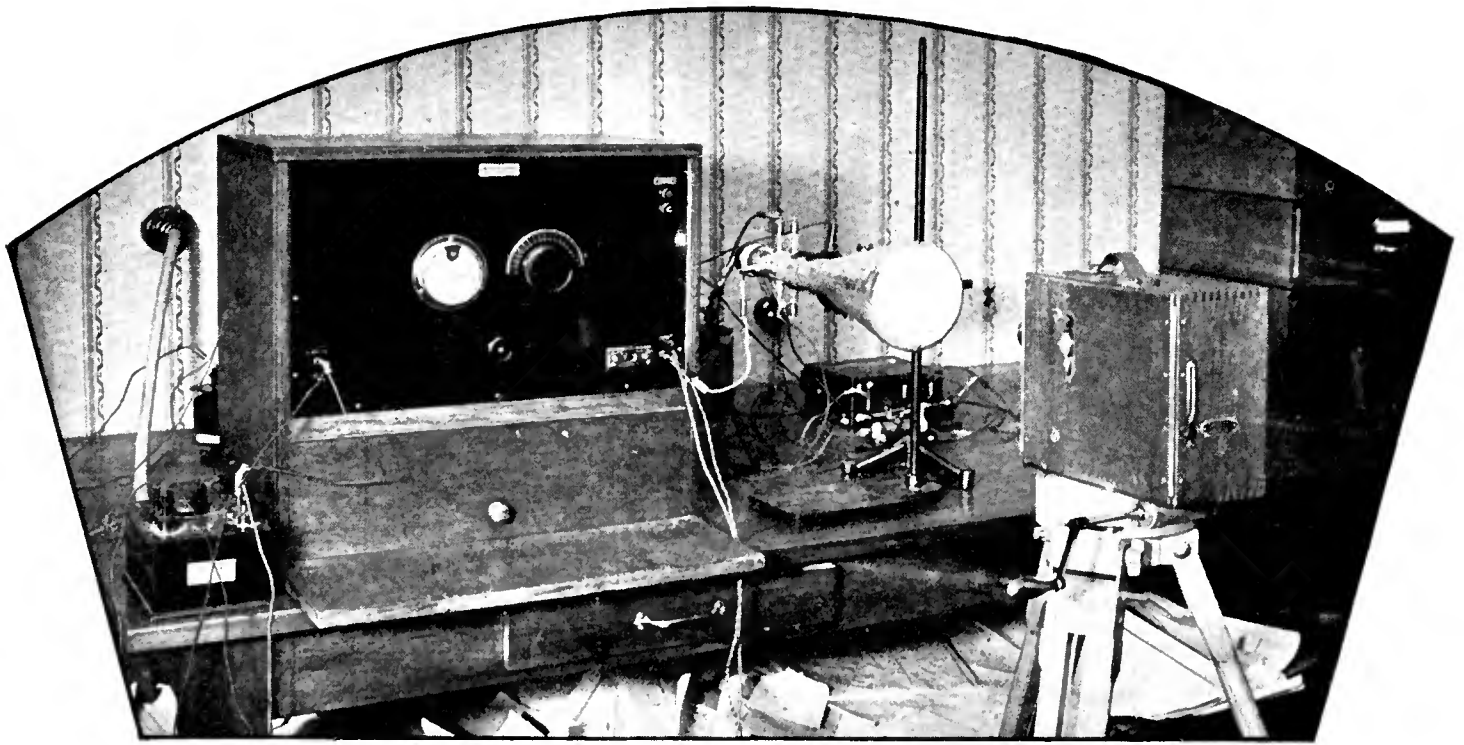

Fig. 2



An untuned amplifier used by the author in his experiments with cathode-ray tubes.

## MEASURING PERCENTAGE MODULATION

*Using the Cathode-Ray Tube for Determining Percentage Modulation. Desirable Characteristics of a Tube Used for This Purpose. Method of Procedure and Some Typical Examples of the Results Obtained by the Author.*

The cathode-ray tube has always been a most useful device in laboratory measurements on all kinds of pulsating or alternating currents. Additional uses for the tube are always being found and in this article Mr. von Ardenne (who has contributed several articles published in the Proceedings of the Institute of Radio Engineers) describes a method of using the cathode-ray tube in the measurement of percentage modulation.

THE DETERMINATION of the percentage of modulation with the Braun tube may be made by two procedures: (1) the method of standing figures and (2) the direct taking of the modulation-time curve.

The procedures included in the first group are the older and have been described numerous times in the last few years. A superficial explanation of the general method for the production of standing figures is as follows: the high-frequency to be demodulated is fed to a rectifier and the low frequency so obtained is coupled to one of the sets of plates of the Braun tube, while the high frequency is coupled to act on the cathode ray at right angles to the low frequency. If an oscillograph is made of a high-frequency transmitter in this way, with the modulating current having a constant frequency and amplitude, and if the high-frequency axis is made the horizontal one, then a figure is to be expected which has for its maximum and minimum widths the corresponding limiting values of the modulated high frequency. If the demodulated low frequency of the transmitter is put on the vertical plates of the tube without time lag, then a stationary trapezoid is obtained on the fluorescent screen. The parallel sides,  $a$  and  $b$ , lie horizontal and the percentage modulation

By **BARON MANFRED VON ARDENNE**

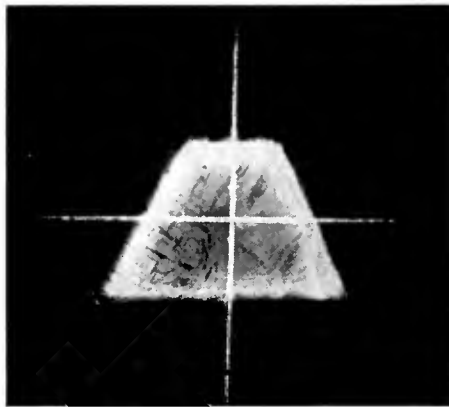

Fig. 1—The photographic result of experiments with standing figures.

of the transmitter can be computed immediately from the expression—

$$K = \frac{a-b}{a+b}$$

The advantage of the method lies in the possibility that tubes with very weak fluorescent spots can be used successfully when the photographic exposure is made long enough. On the other hand, a long photographic exposure is necessary, and in this fact lies a limitation of the use of the trapezoid method, if the transmitter is excited only with a constant amplitude of low-frequency power. If the amount of modulation varies, then the height of the trapezoid also changes so that a measure-

ment of the parallel sides is no longer possible. If a broadcast transmitter is used, in which not only the amount but also the frequency of the modulation varies then the whole trapezoid changes. This will be true particularly at higher frequencies, since phase displacements take place in the coupling elements of the rectifier and amplifier which completely change the boundaries of the trapezoid. Furthermore, the trapezoidal form is only obtained with very small high-frequency amplitudes, since with larger amplitudes at the input of the rectifier, the corners are rounded off.

### *The Second Method*

The second method is free from these disadvantages. It consists in producing a time axis by means of a rotating mirror or a moving film. Naturally this method can be used for any sort of modulation curve, including those of broadcast transmitters, and at the same time it will allow observation of peak values of excitation. How important such a control is in order to maintain a small amount of distortion in the detector of the receiving set is generally understood. Since the envelope of the modulated high frequency is visible on the film or in the rotating mirror, the sinusoidal form can be seen beautifully when the excitation is from a low-frequency oscillator and the complex shape when it is due to speech.

For photographing the modulation curve, it is very important to have a tube which gives a very bright fluorescent spot. The brilliancy of this spot determines the highest speed at which the film can be moved, and therefore the highest modulation frequency which can be recognized on the film. For direct observation of the modulation on a rotating mirror a bright spot of light is also very desirable, since this permits observations in daylight. In

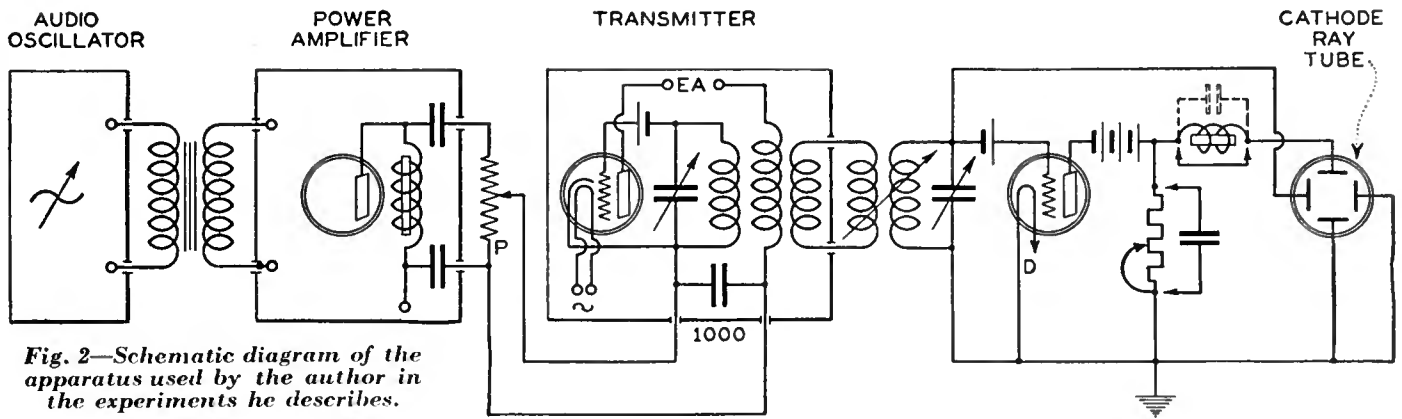

Fig. 2—Schematic diagram of the apparatus used by the author in the experiments he describes.

the following paragraphs a cathode-ray tube is described which was developed in the author's laboratory and which is particularly suited to measurements of this type due to the markedly greater brightness of the spot.

### The Apparatus Used

In making the experimental modulation pictures shown on these pages the most important piece of apparatus was, of course, the Braun tube. This tube, which is shown in Fig. 3, has a fluorescent plate made of a material which fluoresces in blue-violet, and therefore is very active photographically. The picture, Fig. 3, was taken in the dark and shows clearly the path of the cathode ray in the tube. To the right the ray, coming from a concentric cylinder, passes through two systems of condenser plates placed at right angles to each other. The top of the tube is illuminated due to the impact ionization of the small amount of rare gas present. The beam produces on the fluorescent screen an extremely strong point about 0.75 mm in diameter.

In operating the tube it is important to keep the leads to the condenser plates short and the condenser plates themselves must be small. By separating the leads a sufficiently small capacity can be obtained to hold up the impedance so the device will have no frequency characteristic, even at high frequencies.

The heading picture shows the untuned amplifier used with the cathode-ray tube. To the left is a tuned circuit in front of a multi-stage, high-frequency amplifier whose gain is accurately known and can be increased to a voltage amplification of 50,000. After the amplifier, which con-

tains six resistance-coupled stages, is a second tuned circuit which, in turn, is connected to the horizontal plates of the Braun tube. The sensitivity of this arrangement is so great that a strip of light 3 to 4 cm wide can be obtained from a broadcasting station 1000 to 2000 km (600 to 1200 miles) away. The circuit, therefore, can be used to observe the modulation of distant stations.

The arrangement in use at present is shown in the schematic of Fig. 2. It consists of a powerful transmitter using plate modulation which can be excited by an oscillator and power amplifier. The percentage modulation can be adjusted by means of the potentiometer P and can be marked conveniently on the dial from zero to a complete overload. The rectifier shown after the modulator was only used in investigations of the method of standing figures. For the method used in taking photographs of Fig. 4 the rectifier D was omitted.

The determination of the percentage modulation has been made by both meth-

ods. As a source of modulated high-frequency power both the modulated oscillator of the laboratory and local and long-distance broadcasting stations were used. The result of the tests of standing figures is given in Fig. 1, and in making this particular picture the local oscillator was used to supply power. A trapezoid with straight lines for its sides was obtained. In order to obtain this figure two stages of resistance-coupled amplification were used after the rectifier D. In this way it was possible to make the input voltage of the rectifier extremely small by a loose coupling with the oscillator, and thereby reduce the curvature of the rectifier characteristic to such an extent that the rounding of the corners of the trapezoid would not be noticed. The percentage modulation from the two sloping sides where  $a = 35$  mm and  $b = 14$  mm is

$$\left( \frac{a-b}{a+b} \right) \text{ or } 43 \text{ per cent.}$$

It is obvious that the trapezoid method can also be used for broadcasting stations.

However, it is only in the case of picture transmission stations, where the transmitter is modulated with a constant frequency, that the results are particularly good.

The method providing a visible indication of modulation was used for both the modulator and the broadcasting stations. The plate voltage employed was 1500 and this gave sufficient brilliancy to enable making photographs with normal film and a 1:1.5 opening. Fig. 4 (A, B, and C), show the curve of modulation against time for different degrees of modulation, obtained with the potentiometer P in Fig. 2. The demodulated low frequency was 800  
(Continued on page 360)

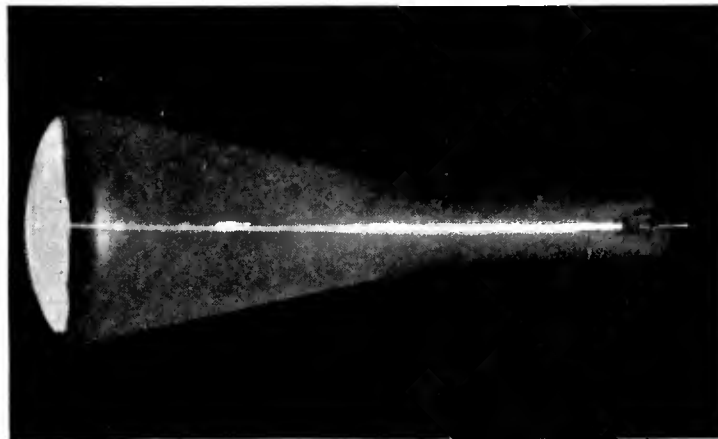

Fig. 3—The Braun cathode-ray tube photographed in a dark room.

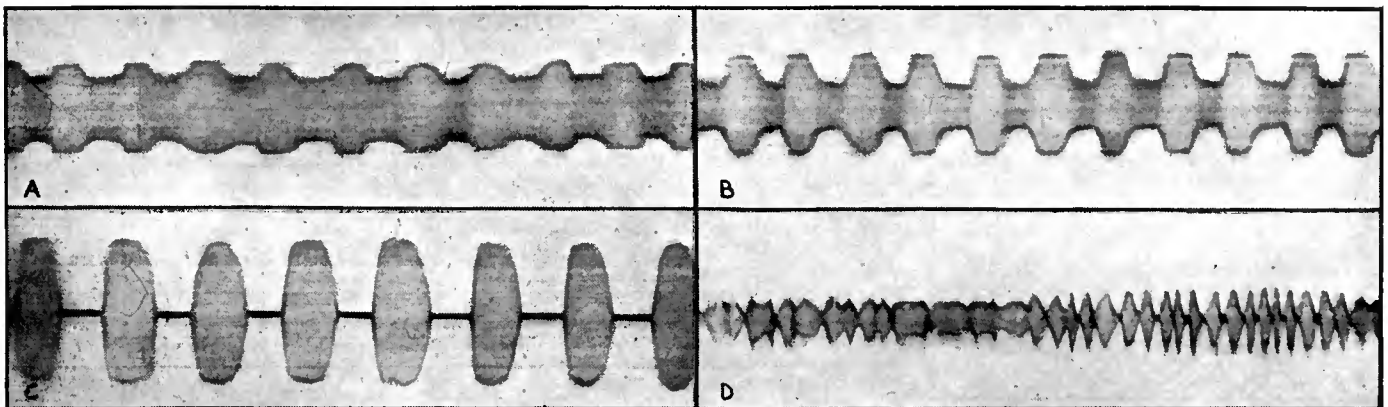

Fig. 4—Oscillograph curves taken on signals of various degrees of modulation.



# AUTOMATIC VOLUME CONTROL

## A General Description of How Automatic Volume Control Circuits Function. Some Details of Experiments on Circuits by the Author.

By A. C. MATTHEWS, JR.

A VOLUME CONTROL on a radio receiving set has three distinct functions to perform, that is to compensate difference in volume of stations at various distances; to compensate any variations in signal strength due to slow fading, and to adjust the volume level to the desired intensity. An automatic volume control accomplishes the first two objectives inherently, while the last function is left to the particular likes of the operator. The setting of the volume level, however, is made only once and thereafter all stations within the range of the receiver are reproduced with the same degree of intensity, assuming, of course, that their percentage of modulation is nearly the same.

Several types of automatic volume controls have been proposed in the past and the following are referred to as examples of the various types.

1. Plate current of the output tube in series with a UX-199 filament arranged so as to vary the bias on a preceding tube, thus preventing overload and limiting the volume. (*Proc. I.R.E.* March, 1928, p. 281.)

2. Varying the plate voltage on the radio-frequency amplifier by means of a control shunting the loud speaker. (*RADIO BROADCAST*, March, 1929.)

3. Adjusting the radio-frequency amplifier bias by means of a two-element rectifier tube. (*Proc. I.R.E.* January, 1928, p. 30.)

4. Varying the bias on the radio-frequency amplifier by means of a three-element tube connected in a simple rectifier circuit. (*Proc. I.R.E.* March, 1929, p. 511.) Of the four systems referred to, the author prefers the last mentioned method, since it has several advantages over the other types.

Experience has taught us that in order to provide automatic volume control without introducing distortion the device must operate on the carrier wave. Any variation in the carrier wave strength must be compensated by an inverse variation in radio-frequency amplification. The type of automatic volume control described in this article meets this requirement and is exclusively for use with the a.c. screen-grid tube (UY-224). Since it is permissible in screen-grid receivers for the volume control to vary the screen-grid potential,

it was thought advisable to devise some scheme whereby this method might be accomplished automatically so as to compensate any change in signal strength, thus giving us an automatic volume control.

As may be seen in the accompanying diagram, the carrier signal is applied to a rectifying circuit and the rectified a.c. component is impressed back on the preceding amplifier screen grids, thus

*This article by Mr. Matthews, formerly a radio engineer with the Stewart-Warner Corporation, describes some experiments on automatic volume control circuits for use with screen-grid tubes. The control system which is described operates automatically and varies the amplification of the r.f. amplifier tubes by varying the voltage applied to the screen grids of the screen-grid tubes.*

—THE EDITORS.

regulating their amplification inversely with the original signal. In other words, when a signal on the regular detector exceeds a certain predetermined value the bias on the volume-control tube is reduced and its plate current increases. This increase in plate current is used to obtain a voltage drop across a 25,000-ohm resistor, thus decreasing the screen-grid potential on the r.f. tubes and thereby reducing the overall amplification. Since the amplification curve of the screen-grid tube slopes rather rapidly as the screen-grid potential is increased, this makes a very effective volume control.

The circuit constants of the volume-control tube have been arranged so as to adjust the time constant of the circuit correctly in order that no appreciable time lag will occur when the carrier wave suddenly varies in intensity. However, the time constant is not high enough to prevent correct operation on low modulated frequencies.

Since the volume-control tube must have its plate at the same potential as the screen-grids of the r.f. amplifier, it is necessary, in order to obtain the correct plate voltage on the UY-227 volume-control tube, to take off voltage taps at -60 and -80 volts on the power-supply unit. This puts a potential of approximately 135 volts on the plate with respect to the cathode.

The volume level may be set at any predetermined value by adjusting the bias on the volume-control tube. Fig. 2 shows curves taken with and without the automatic volume control. A, B, and C show the peak voltages on the first a. f. grid at three different volume-control settings. With the volume control in the position for maximum signal the sensitivity of the set is not impaired in the least, in fact the only indications that an automatic volume control is being used are due to the absence of fluctuating signals and the usual blasting encountered when tuning through a local carrier wave. Also when the sensi-

tivity of the set is being taxed a noticeable fluctuation in the background noise will be very much in evidence as the sensitivity is varied in order to compensate the decrease in signal strength. This one disadvantage, however, is more than offset by the many desirable features of this type of volume control and in the opinion of the author it is negligible. Curve D shows the peak voltage on the first a.f. grid with the automatic volume control disconnected. The sudden change in curve D is due to detector overload.

When the volume is once adjusted all stations within the receiving range of the set are reproduced with the same volume providing the modulation of all the stations received are nearly alike. This is very convenient when tuning through the carrier of a local station since very bad blasting will occur unless some sort of limiting device is utilized. When using this type of volume control the plate current of the r.f. amplifier is at a minimum when the receiver is tuned exactly to resonance and since the volume does not fluctuate it is difficult to tune the receiver unless a plate milliammeter is used as a resonance indicator.

### Recent Changes

Since doing the laboratory work described in the preceding test certain slight modifications in the circuit constants have been found desirable. Although these changes do improve the practical operation of the circuit, they do not alter the operating characteristics of the system, so the curves of Fig. 2 still apply.

The first change found necessary was reducing the capacity of the coupling condenser from 250 micromicrofarads, as indicated in Fig. 1, to 100 micromicrofarads. The smaller capacity helps to prevent any grid rectification from occurring when receiving strong signals.

Also it is general practice now to operate the screen-grid tubes at a screen potential of 75 volts instead of 67 volts as originally specified by the tube manufacturers. The higher operating potential requires the use of a somewhat larger plate resistor for the volume-control tube, but, as stated previously, this does not alter the essential operating characteristic of the control circuit.

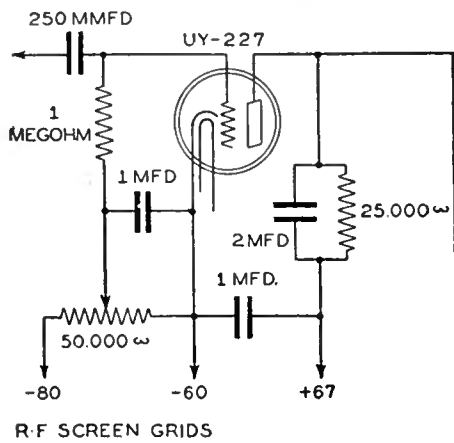

Fig. 1

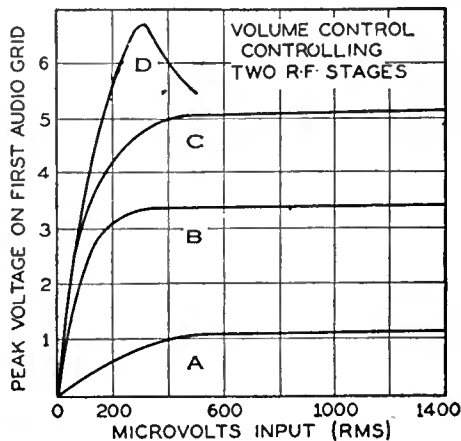

Fig. 2

## FACTORS GOVERNING AMPLIFICATION

THE VACUUM TUBE is unique among modern machines in that it amplifies power, differing in this respect from a transformer which amplifies voltage at the expense of current or *vice versa*. Strictly speaking this is not true, i.e., the tube and associated apparatus, considered as a whole, does not amplify power. For example, if you calculate the total power going into a tube, say a 245-type power tube, and calculate the total useful power coming out you will see that there is an overall loss of power. But if you neglect the filament power and the waste of power in heating the plate and consider only the input power fed to the tube as compared to the useful output power, you will see there is amplification.

What actually takes place in the amplifier is something like the following; a small amount of power is utilized to operate the tube acting as a valve which releases a large amount of power from a local battery.

Example: In Fig. 1 consider a power tube getting its input voltage from a.c. flowing through a resistor, and feeding power into a load resistance. The input voltage is the product of the current and the resistance. The output power is the product of the current squared through the load and the load resistance. Thus,

$$\begin{aligned} \text{Input voltage} & E_i = I_i R_i = E_g \text{ r.m.s.} \\ \text{Input power} & P_i = I_i^2 R_i \\ \text{Output power} & P_o = I_o^2 R_o \\ \text{Output current} & I_o = \mu E_g / (R_o + R_p) = \mu E_g / 2R_p \text{ if } R_p = R_o \\ \text{Output power} & \frac{\mu^2 E_g^2}{4 R_p} \\ \frac{\text{Output power}}{\text{Input power}} & = \frac{\mu^2 I_i^2 R_i^2}{4 R_p I_i^2 R_i} = \frac{\mu^2 R_i}{4 R_p} \end{aligned}$$

Putting the proper values for a 245-type power tube into this equation, the power gain, i.e., the ratio between power output and power input, is about 15 times.

### Coupling Devices

The tube, no matter how much amplification it may produce standing by itself, is useful only when connected with associated apparatus. We put a voltage into the tube and extract some power out. This voltage must be put in by means of accessory apparatus; the power output must be delivered to some load apparatus.

The usual means of coupling one tube to another are well known to every experimenter, viz., resistance, inductance, or transformer, but it is not every experimenter (or engineer either) who, without a great deal of hemming and hawing, can tell you how many stages are necessary to deliver a certain amount of power into a given load when the input is known, or how much is the overall gain of a two-stage, transformer-coupled amplifier, or whether it is better to put a transformer stage ahead of a resistance stage when combinations are used.

In resistance-coupled amplifiers, about 75 per cent. of the amplification factor of the tube can be

realized. The amplification factor is a term which indicates the output voltage which would exist across an infinite resistance load if one volt were impressed on the tube. Unfortunately an infinite resistance load is unattainable and some of the total voltage available in the plate circuit of the tube is used up in heating the plate of the tube and is not employed usefully. Therefore, not all of the voltage amplification of the tube can be used. If the load resistance is

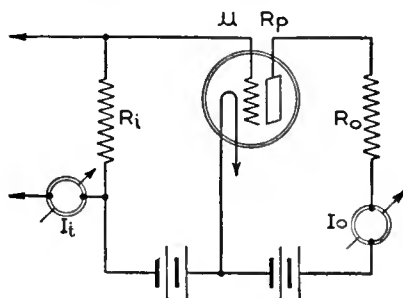

Fig. 1

three times the tube resistance, three times as much voltage will appear across the load as across the tube (we are speaking of a.c. voltages), and therefore the voltage amplification will be  $\mu \times 75$  per cent.

In a transformer-coupled circuit, the primary inductance into which the tube works is very high and, because of the fact that the total impedance in the plate circuit must be obtained by taking the *vector sum* (see "Home Study Sheet" No. 10, Nov. 1928), the actual voltage amplification obtained will be about 89 per cent. of the  $\mu$  of the tube if the reactance into which the tube works is twice the tube resistance in ohms. This will be true at the frequency at which the reactance of the transformer is twice the tube resistance, and, since the maximum obtainable is only 100 per cent., the variation in amplification can be only between 89 per cent. and 100 per cent. At all frequencies higher than that at which the transformer reactance is twice the tube resistance, the amplification will be greater than 89 per cent. of  $\mu$  and will approach 100 per cent. as a maximum.

### A Typical Problem

Suppose then you have a detector capable of putting out one volt, and that you need to have 50 volts on the input of a power tube to deliver the required amount of power. How many stages of a.f. amplification, each using

a three-to-one ratio transformer and a tube with a  $\mu$  of 8, are necessary? What C biases will be necessary? The circuit is in Fig. 2. It is only necessary to calculate the voltage input to the first a.f. stage by multiplying the voltage across the a.f. transformer primary by the turns ratio, then, by multiplying this voltage by 90 per cent. of the  $\mu$  of the tube, you get the a.c. voltage across the primary of the next transformer and so on until the voltage available for the power tube grid is ascertained.

Now suppose you want to use two resistance stages and one transformer stage—if, for example, two transformer stages give not quite enough amplification. Should the transformer or the resistance stages come first or should the arrangement be first a resistance stage, then a transformer stage, and finally a resistance stage? The way to solve this problem is to make diagrams of the three possible cases, figure the voltages that will appear on the grid of each tube, and therefrom find what the C bias on these tubes must be.

If the transformer stage comes first, the voltage on the grids of the following tubes will be rather high, which will require high values of C bias, and because of this high bias a high plate voltage will be needed. Since these tubes are fed through plate resistors in which there is a drop in voltage of one volt per thousand ohms for each milliampere plate current, a large plate battery will be required. For example, suppose the voltage on the grid of a resistance-coupled stage calls for a C bias of 3 volts. If the tube has a high- $\mu$  this will call for a plate potential of probably 180 volts (so there will be a sufficiently long straight portion of the characteristic to handle the 3-volt input), and if the tube takes 0.5 mA. at this voltage working through 200,000 ohms, a plate battery potential of 280 volts will be necessary.

On the other hand, if the input voltage to this tube is quite small, for example, when worked directly from the detector, a small C bias will be necessary, a shorter portion of the characteristic need be straight for distortionless amplification, and hence lower plate battery voltages are required.

Thus if a combination amplifier is to be constructed it is better to place the resistance stages before the transformer stage.

### Overall Amplification

Very few radio workers have much conception of the total amplification attained in modern radio receivers. They do not know how this voltage gain is distributed. They do know that the advent of the screen-grid tube has shifted the proportion of amplification that exists before and after the detector. But how much? This is answered in "Engineering Sheet" No. 34. This sheet also considers the amplification which may be obtained in circuits using present types of pentodes.

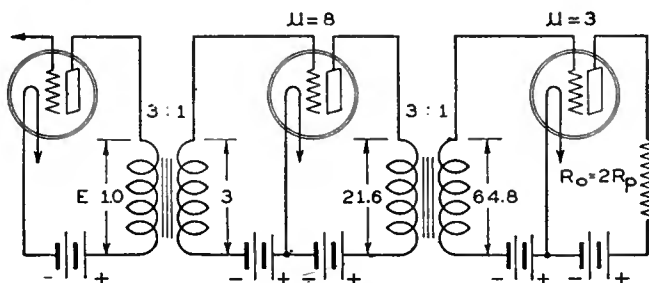

Fig. 2

## CALCULATING AMPLIFICATION OF PENTODE RECEIVERS

THE ADVENT OF TWO new tubes, the screen-grid pentode and the power pentode, is sufficient cause to sit down and calculate the present gain of receivers, and what will happen if set designers choose to use these new tubes.

The new screen-grid tube is roughly 1.25 times as good as present-day screen-grid tubes. That is, it will deliver about 1.25 times as much amplification. The power pentode is about 5 times as sensitive as a 245-type tube. That is, to deliver 2000 milliwatts it requires only 12 volts input whereas the 245-type tube requires 50 volts to deliver about the same power output, 1600 milliwatts.

Suppose a receiver, Fig. 1, has push-pull 245-type tubes working directly from a detector through a transformer with a turns ratio of 5 to 1. Across the secondary of the input push-pull transformer is required 100 volts if the power amplifier is to be "loaded up." Therefore, a potential of  $100 \div 5$  or 20 volts is needed across the primary. This is the a.f. voltage the detector must deliver. This calls for a power detector, i.e., a highly biased detector probably of the 227 type. At 22 per cent. modulation and working into 200,000 ohms, such a tube will deliver one volt a.f. for each volt r.f. put on its grid. If the modulation reaches 100 per cent., as it may from many modern stations, the output will be roughly 5 times the r.f. input voltage. This is the maximum voltage that will never be reached and should be just enough to put 100 volts across the two push-pull

transformer. How many stages are necessary? Three stages will give a total of 27,000, more than is necessary. Therefore, somewhat looser coupling to the antenna can be used with increased selectivity and greater freedom from unwanted noise, or a smaller antenna can be used (the ice pick, for example, as one manufacturer—Silver-Marshall—advertises.)

Think back to receivers of a few years ago which had a resistance-coupled buffer stage between antenna and the set, in which there was a

input must be  $12 \div 40$  or 0.3. In other words, substituting a screen-grid detector in place of a low- $\mu$  tube and transformer causes a gain in sensitivity in the ratio of 2 to 1 (6 dB).

In addition to this gain in sensitivity there is a possible saving in money due to the substitution of a condenser-resistance coupling unit in place of a transformer. In Fig. 2 is the complete screen-grid-detector, pentode-output-tube receiver. We now need a gain of only 750 in the r.f. amplifier in place of 10,000. If each tube gives a gain of

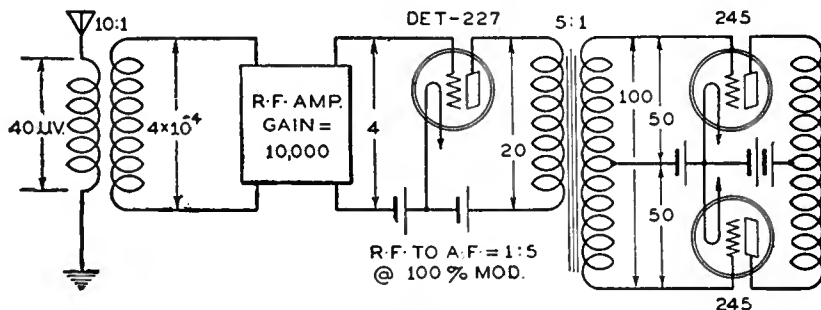

Fig. 1

voltage gain of perhaps 3, plus two r.f. stages using 201A-type tubes. What was the total amplification up to the detector? About 500 at a maximum unless there was considerable regenerative amplification. This meant that a grid leak and condenser detector, which is about 10 times as sensitive as a C-bias detector, was necessary. Then

30, two stages will be somewhat more than enough and we have a receiver with two r.f. stages using screen-grid tubes, a screen-grid detector, and a pentode power tube—four tubes in place of present-day sets using five or more (usually more) tubes.

Such a receiver represents no great advantage over present sets. The reduction in the number of tubes needed may make necessary greater filtering to reduce the a.c. hum in the output; and because fewer parts are required does not mean that these parts may not have to be better, thus keeping the total cost at approximately the same figure.

If the screen-grid tube of the future is better than present tubes of this type, still fewer stages may be possible, but it does not seem likely that a single r.f. tube will ever take the place of two stages as it is too difficult to pack into one tube and its circuit all the gain required. The problem of calculating the voltage gain in a receiver or amplifier has been illustrated by this "Engineering Review Sheet"—and that was the object in view.

### Problems

1. Four milliamperes of current at 1000 cycles are fed through a 10,000-ohm input resistor. The voltage across this resistance is applied to a 245-type power tube whose amplification factor is 3.8 and whose plate resistance is 2000 ohms. Calculate the input and output power and the power amplification.

2. The power obtained from a tube is a maximum when the output resistance is equal to the tube resistance, as in Problem 1, but the maximum *undistorted* power is secured when the load has twice the tube resistance. Calculate the power into a 4000-ohm load and notice how little power is lost in not exactly "matching" the tube and load.

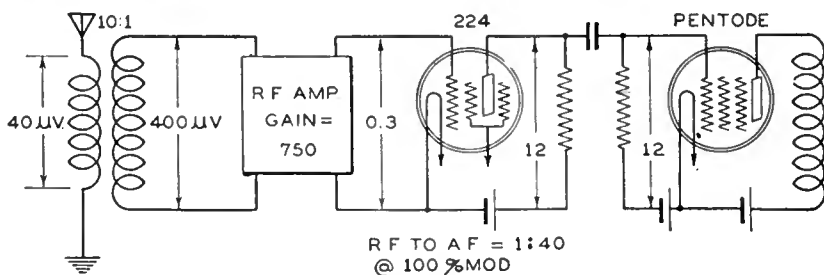

Fig. 2

tubes. Thus, if the input to the detector is 100 per cent. modulated, the r.f. voltage to deliver 20 volts a.f. need be only 4 volts.

### A Practical Case

We need, therefore, an input r.f. potential to the detector of 4 volts. Now suppose we are situated in the field of a transmitter such that across the antenna appear 40 microvolts. How much amplification must there be between the input to the set and the input to the detector? Obviously the amplification is 4 volts divided by 40 microvolts or a total voltage amplification of 100,000. Now between the antenna and the input to the first r.f. tube there is usually a gain of 10, so between the first r.f. grid and the detector grid there must be a voltage gain of 10,000.

Suppose it is possible to obtain a voltage gain of 30 per stage from a screen-grid tube and its accompanying

came two stages of transformer-coupled a.f. amplification with an overall gain of about 72. What was the total voltage amplification?

Now suppose you use a pentode power tube requiring only 12 volts to deliver 2000 milliwatts. If worked from a detector with a four-to-one transformer the detector output need be only 3.0 volts, and at 100 per cent. modulation the r.f. input to this detector need be only 0.6 volt instead of 4 volts; thus we can get along with one-seventh ( $1/6.7$ ) as much amplification in the r.f. amplifier.

Suppose you want to use a screen-grid detector which has a conversion factor of about 40 to 1, i.e., a 100 per cent. modulated r.f. signal of one volt will deliver 40 volts a.f. It must be coupled to the power tube through a resistance (because of the tube's high resistance) and so the gain in the transformer will not be secured. We need 12 volts output and so the r.f.

# PROFESSIONALLY



# SPEAKING

## 1930 AND SERVICE

IF, AS THE general service manager of a large and well-known radio manufacturer believes, the 1930 service problem will be one of negligible importance, the entire industry will have put behind it a most serious problem. The question of whether a manufacturer should send service literature to the "independent" serviceman or whether he must compel all servicing to be handled by servicemen attached to authorized dealers has been solved by the majority of manufacturers to their own satisfaction. The "independent" has no place in this picture. The reasons as cited by the service manager quoted above are:

1. He (the "independent") does not fit into the manufacturer's scheme of positive control over field service organizations.

2. The manufacturer has no claim upon his loyalty.

3. He is under no obligation to execute the manufacturer's policy with respect to guarantee, etc.

4. There is nothing to prevent the discontinuance of his activities in any locality thereby leaving that place without adequate service facilities.

5. The manufacturer cannot logically support his own field service organization on the one hand, and encourage the independent service organization as a group on the other hand.

Granting all these points, and granting the fact that we are not on the firing line of service but are in a comfortable office far from the front, we believe there is but one attribute of service that needs consideration—is the service adequate? This means, does the remedy cure the ill, is the cost commensurate with the effect secured, and does the service require only a reasonable amount of time?

We believe that being connected with a dealer is no assurance that a serviceman is a good one. On the other hand, we believe such a serviceman is probably not as good as his brother who gets out and hustles for himself. As soon as a serviceman learns his calling and becomes an efficient and effective unit, he discovers that the meager salary the dealer can afford to pay is less than he can make on his own. Therefore, he gets out of the dealer's shop and goes after business for himself.

One trouble seems to be that a dealer cannot afford to hire a good man. The serviceman can make more money on his own; therefore, he becomes an "independent."

Perhaps some scheme like the following would work out. We have already suggested that the manufacturer pick all servicemen by a technical examination. This would obviate the difficulty that the dealer, not being a technical man himself, has trouble in knowing a good serviceman when he sees one. After the prospective serviceman has passed the examination, let the dealer take him on and, except for a percentage of the income to pay for the service share of the rent and for the use of

the dealer's instruments, let the serviceman take all the profits.

The examination will prove that he is a good technician; the fact that all the money goes to the serviceman makes it possible for him to work as hard as he likes with the certainty that the money will be his.

The tendency for large dealers to farm out their service is a step toward the latter scheme. It is a fact that no dealer can afford to pay a serviceman enough money to make it worth the while of the latter to stay out of the "independent" rôle. The farming out process can take place only in

## Attention—

*Why the industry does not recognize the independent radio serviceman.*

*A solution to the combined problems of radio dealers and servicemen.*

*How will the pentode tube improve radio receiver design?*

large communities, and, although a large percentage of all sales is made by a small number of dealers, these sales take place where there is plenty of service available. It is the customer in small districts who needs service the most and who has the least chance of getting it.

But let us hope that the 1930 service problem will be one of negligible importance. If 1930, however, is marked by another race to see who can make the most receivers at the lowest price, we believe there will still be a service problem of considerable importance.

## NEW TUBES

A new tube which had been spoken of quite calmly in Europe finally broke into the public press in January, thereby disturbing the entire radio industry to a considerable degree. This tube is the pentode, a five-element tube. In Europe it had taken the form of a power-output tube of superior sensitivity and efficiency. In this country there are two such tubes, the power-output tube and a screen-grid tube with an additional grid.

The pentode power tube came into the limelight slowly and was demonstrated before a well-attended meeting of the Radio Club of America. Knowing the propensity of the newspapers to exaggerate the importance of any technical development, the authors of the paper "hedged" and said the new tube would not make any startling difference in radio receiver design.

The other pentode was announced by a tube manufacturer with the statement that it would make possible a \$50 receiver by cutting out sufficient tubes from the present type of sets. It was described as twice as good as present-day tubes. The newspaper writers took up the matter with great glee and soon the trade associations thought

something ought to be done about this pentode business before the public began to look for the new set and to refuse the old.

The statement of the trade association was made with very little regard for the cold hard facts with which the engineering profession deals and which, we believe, ought to be interpreted to the buying public. The statement denied practically everything that had been said in favor of the new tubes.

Aside from whether or not the various statements were ill advised and devoid of facts, the situation is indeed unique. So far as we know, for the first time in the history of the industry a tube manufacturer developed a tube in his own laboratory and instead of hiding his light under a bushel until he could get tooled up or had sold the rights or whatever it is you do to corner the other fellow's market, he distributed characteristics of the tube to engineers and asked their suggestions.

Set engineers have asked such co-operation before. They have wanted tube designers to present their characteristics, and ask for the suggestions of circuit engineers so that the final tube design could be worked out with the circuit people in mind. While it is quite probable that not a dozen circuit engineers in the country have any ahead-of-the-minute ideas about what to do with a new tube when one is presented for criticism, it is a good idea anyhow. Let the tube people make a tube, and ask the circuit people how to make it better for their needs. Conversely, let the circuit people lay down a diagram and beg for a new tube to fit into it.

Let us look at this pentode business seriously. There are two kinds, the power tube and the amplifier. The pentode power tube delivers about the same output as a 245-type tube but is roughly 15 db more sensitive. Calculations on page 338 of this issue show that such a tube with a screen-grid detector ought to make it possible to get along with only four tubes plus a rectifier and make a set just as good as present-day sets with more tubes. But you still need two stages of r.f. amplification, and therefore, even if a new screen-grid tube which was twice as good as present tubes made its appearance, it would not be good enough (because the overall gain of two stages is the product and not the sum of the individual stages). In other words, the pentode voltage amplifier is not good enough to act with a power pentode to make a three-tube set practicable. It is better, but not enough.

The pentode power tube will undoubtedly fit into the picture of many manufacturers. There is no reason for everyone to rush into the design and production of a pentode set, because the public won't be able to tell the difference, except perhaps in price. It makes a four-tube set possible but not a three-tube set. As for the screen-grid pentode, it must be proved that it really is worth the bother of adding terminals to the base and to the socket and other circuit changes.



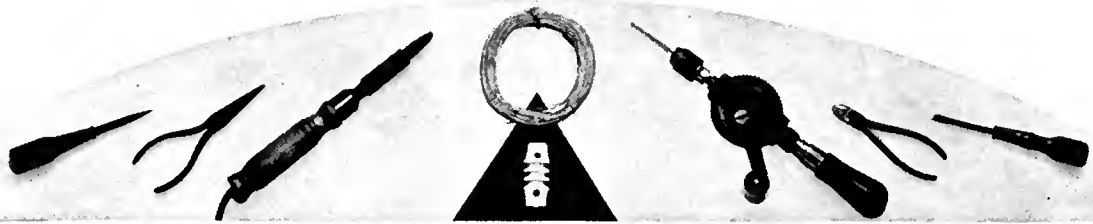

## THE SERVICEMAN'S CORNER

### Technique of Servicing

BORIS S. NAIMARK, one of our regular New York City correspondents, sends us the following notes on a neglected subject.

"Did it ever happen to you—you being a good and conscientious worker—that just as you were putting the finishing touches on an ailing receiver you let your screw driver slip and left a glaring scratch in the most conspicuous part of a beautiful and highly prized cabinet?"

"Anticipating the possibility of such occurrences in every day service work, I obtained, through an authorized Philco dealer, a cabinet touch-up kit known as Philco Part Number 3309, and containing all the materials necessary for minor cabinet repairs. I have found that this work is not at all difficult and can be handled by any serviceman after very little practice.

"The Philco kit enables one to touch up scratches and white edges on cabinets, and consists of the following materials:

Burning-in Wax: Dark Red, Brown, and Red.

Powdered Stain: Bismarck Brown, Van-dyke Brown, Burnt Umber, and Malachite Green.

Also: Liquid White Shellac, Alcohol Lamp, Wood Alcohol, Felt Block, Felt Pad, Rubbing Oil, Steel Wool, and Knife.

"To touch up light finishes take a small amount of the stain nearest the cabinet color and dissolve in a quantity of white shellac. A little of the green stain added to the darker colors will make them lighter. Having obtained the right color, apply it with a pencil brush to whatever parts need touching up. Let this dry and then apply a coat of white shellac. If this has too high a gloss rub lightly with the felt block and rubbing oil.

"To burn-in scratches and bruises, heat the knife over the alcohol flame. When the knife is sufficiently warm apply wax of the proper color to the scratch and smooth it down with the knife. This is then rubbed with the felt block and rubbing oil. If too high a gloss is thus obtained it can be dulled easily by rubbing lightly with steel wool."

### WATCH THE SOLDERING IRON

"In using an electric iron on a set which is hooked up it is a wise precaution to remove all of the tubes or better still to disconnect the receiver from ground and 110-volt supply. One wire of your

*Optimistic declarations on the part of some writers to the contrary, the lot of the serviceman is not altogether a happy and prosperous one. The salary of a serviceman in the employ of a dealer is rarely commensurate with his ability and skill. The independent serviceman, working on his own hook, and perhaps under contract or verbal agreement with several dealers, is much better off, but it is not the easiest thing in the world to so establish himself. The serviceman is invited to read "An SOS To The Established Serviceman" in this department and to write us concerning the most advantageous solutions of his several problems.*

—The Editor.

house current is grounded; also one side of the radio set runs to this common ground. It cost me two power tubes to find out that a brand new electric soldering iron can have a short in the case. I was put-

ting a series of by-pass condensers across a B battery and had the switch turned off in the set; nevertheless I got a short from the iron which allowed the 110-volt a.c. to run through the filament circuit on the a.f. side and two new tubes 'went west.'"

J. B. TEMPLE, Toronto, Ont.

### Mounting Loud Speakers

A moving-coil loud speaker can be mounted advantageously in the upper corner of a room as suggested photographically on this page. An installation of this kind will appeal even to the discriminating customer, and is acoustically very fine. It is essential, however, that the louvres be cut in the baffleboard, or the effect will be drummy. Also mount the loud speaker from one quarter to one half inch behind the opening for the best reproduction.

The idea of compensating tone discrepancies by moving the cone nearer to or farther from the opening in the baffleboard is also suggested by H. D. Hatch, of Wollaston, Mass., who writes:

"A customer recently complained that her Magnavox electrodynamic loud speaker gave a hollow sound on voices. After assuring myself it was not due to the set I loosened the loud speaker and moved it back from the opening in the baffle. The idea was to reduce the baffle effect on the longer waves or low notes. Turning the set on I moved the loud speaker back and forward until the customer was satisfied."

### A Hum Filter

An arrangement for the reduction of hum in special cases, which, by the way, should be effective in reducing certain forms of artificial static, is suggested by an engineer now with the Bureau of Standards.

"Certain radio receivers, under the proper (or rather improper) conditions, will hum rather badly when a station is being received, even though the hum level may be very low when no signal is tuned in. This phenomenon has been noticed in a number of receivers, both factory- and home-made, although with the same receiver it may occur under certain conditions and not under others.

"The effect is apparently caused by pick-up from the power line as well as from the antenna, although the nature of the interaction of these two pick-up voltages to produce the hum is not entirely clear. A poor  
(Continued on page 342)

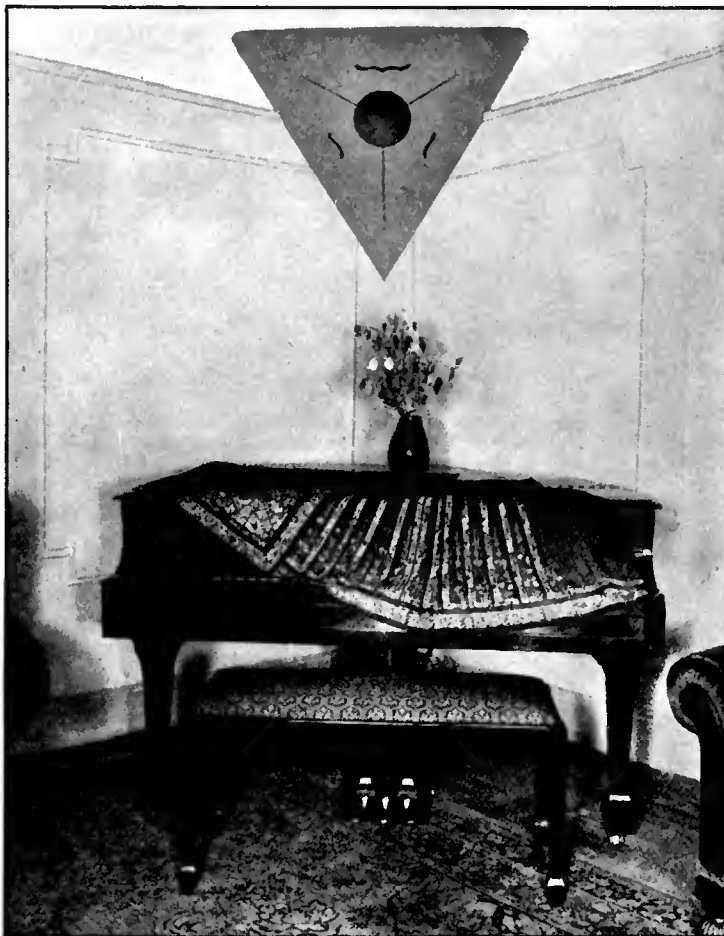

A method of mounting the moving coil loud speaker effectively from both esthetic and acoustic points of view.

# REVOLUTIONARY!«

## IN CONSTRUCTION AND PERFORMANCE

# EVEREADY RAYTHEON 4-PILLAR TUBES

NOW you can sell your customers something really new . . . Eveready Raytheon Tubes! Let them hear the rich, full-voiced tone, the breath-taking realism of Eveready Raytheon reception. Demonstrate it, in their own radio sets . . . then tell them reception will *always* be better if they put a new Eveready Raytheon in each socket *whenever the tone begins to sound fuzzy*.

You can HEAR the difference and SEE the reason

Look at the illustration on this page, showing Eveready Raytheon's 4-Pillar construction . . . a sound improvement. See the solid, four-cornered glass stem, with the four rigid pillars imbedded in it, anchoring the elements. No other tube is permitted to use this construction, for it is patented and exclusive with Eveready



Raytheon.

Before the day of dynamic speakers and screen grid circuits, the old, flimsy, "gas-mantle" construction may have been satisfactory. But present-day radios need tubes with 4-pillar rigidity.

No legal entanglements!

Eveready Raytheons are licensed tubes. They come in all types, and fit the sockets in every standard A.C. and battery-operated receiver now in use. Ask your jobber, or write us now for the names of jobbers near you.

★ ★ ★

The Eveready Hour, radio's oldest commercial feature, is broadcast every Tuesday evening at nine (New York time) from WEAJ over a nation-wide N. B. C. network of 30 stations.

NATIONAL CARBON COMPANY, INC.

General Offices: New York, N. Y.

Branches: Chicago Kansas City New York San Francisco

Unit of Union Carbide  and Carbon Corporation

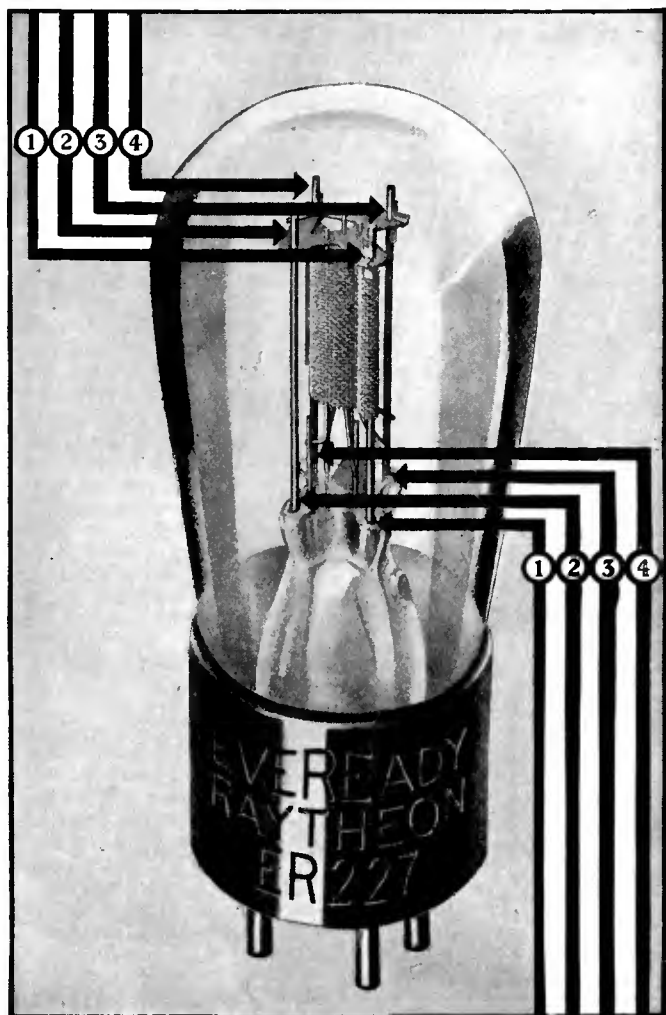

# EVEREADY RAYTHEON

Trade-marks

(Continued from page 340)

grounded connection appears to accentuate the hum.

"The remedy is obvious—a filter in a power line to eliminate the pick-up from that source. This filter should be as close to the radio set as possible. In most cases, two 0.5-mfd. condensers connected in series across the power line, with the center tap connected to the ground post of the set, provide sufficient filtering (Fig. 1). In more obstinate cases, two radio-frequency chokes may be connected on the

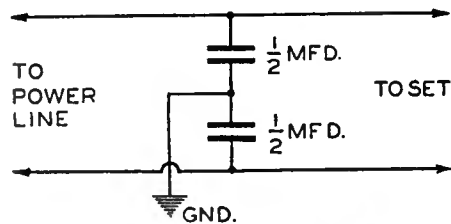

Fig. 1—An elementary r.f. filter for the power line.

fine side of the condensers, as shown in Fig. 2. These chokes may be made by winding 150 turns of No. 18 d.c.c. wire in approximately seven layers on a form one inch in diameter.

"One word of caution: With such a filter, the ground post of the set is alive and the power-supply plug should be pulled out of its socket before any ground connections are made or changed. The slight current passing through the filter condenser to ground has practically zero power factor and consequently will not register on the meter, but when the ground connection of the set is open, the ground post of the receiver is at the potential of the line above ground, and a person making or changing ground connections is liable to receive an uncomfortable shock. The slight disadvantage of a "live ground" post on the set is more than offset by the improvement obtained in reception with receivers afflicted by this type of hum. That this is true is evident from that fact that certain manufacturers include filters of this type in their power packs to guard against the chance that the receiver may be operated under conditions which would tend to introduce the hum."

### Servicing the Radiola

"Here are a few more service notes which may help my brother servicemen who are called upon to render service to Radiola purchasers, as well as users of other receivers. As complete as RCA service sheets are they do not provide solutions to the problems listed below:

"The first puzzling phenomenon was that of a Radiola 66, a receiver of the "superhet" type, from which came an unearthly racket of such intensity that a 1000-watt local transmitter could not even be heard. At first I suspected a faulty connection in the r.f. amplifier and I gave the set a very thorough test. Not a thing could be discovered. By chance I removed the dial light and upon trying the set again found that it was working satisfactorily. A new dial light fixed the trouble. In this connection it was curious to note that the dial light did not flicker or give any sign of defect.

"It may be that some of my brethren have had trouble with Radiola 44 and 46 screen-grid model receivers, such as lack of sensitivity or a resonance howl on tuning in a loud signal (a howl very much like that given out by a microphonic detector tube). Another trouble is poor volume and sensitivity at one part of the dial.

"In these receivers there are three small

trimming condensers with which the gang condensers can be lined-up. It will be noticed at times that a signal of 1200 kc. will come in very loudly but one at 600 kc., same power and distance, will not. No matter how the trimmers are adjusted there seems to be some discrepancy. To remedy this, loosen the two screws that hold the stator plates to the small strip of bakelite, move the stator plates a trifle closer to the rotor plates, and then reset the trimmers. It will be found necessary to move but one set of stator plates. To increase volume on the early models, increase the screen-grid voltage."

JAMES A. ROBINSON, Radiotrician and Radiola Dealer, Methuen, Mass.

R. L. MINOR, serviceman with the O. K. Houck Piano Company, Little Rock, Ark., keeps the ball rolling:

"A Radiola 46 was found which would work if the power unit was tilted but not if mounted normally. Examination disclosed a needle pointed tip of solder projecting from one of the terminals on the voltage divider resistor and penetrating the insulation of a lower potential wire beneath it when the weight of the unit was upon it. The needle point of solder and microscopic hole in otherwise perfect insulation eluded several careful examinations by the writer."

### Data on Crosley Sets

Checking Up On The Showbox: "The Crosley Showbox has friction connections between the rotors and rotor terminals which should be checked occasionally and tightened if necessary. Also there are set screws on both ends of the variable condenser shaft, two on the dial wheel, and one on the other end which compress the springs responsible for keeping the sections in alignment. In case of low sensitivity on these receivers, give this your first consideration."

A. A. WILLITS, Willits Radio Service, Fort Dodge, Iowa.

"I was called in to service a seven-tube Crosley a.c. set. Upon testing with set

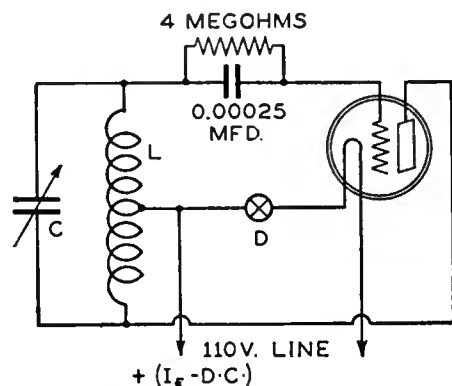

Fig. 3—A simple oscillator for general testing purposes.

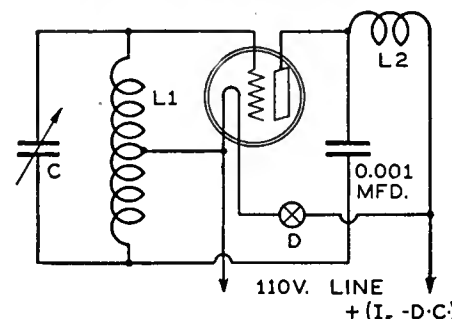

Fig. 4—A variation of Fig. 1 with parallel feed.

analyzer I found zero voltage on the plate of the first a.f. tube. After removing the receiver from the cabinet I discovered a rubber-covered resistor that, with the set turned on, got so hot that I could not touch it. I disconnected the condenser connected to it, tested it with 4.5 volts in series with a high-resistance voltmeter and found it shorted.

"I have found it pays to watch the condensers in the low-priced sets."

C. WASHBURN, JR., Jacksonville, Fla.

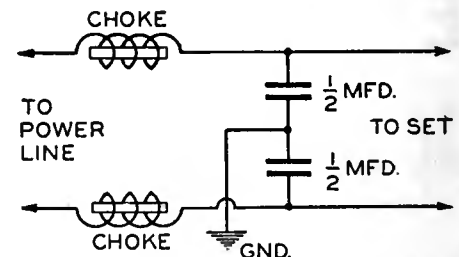

Fig. 2—Using r.f. chokes for additional filter action.

### Two Simple Oscillators

The engineering department of the Jewell Electrical Instrument Company suggests the circuits illustrated in Figs. 3 and 4 as oscillator arrangements particularly adapted to the requirements of the serviceman.

In Fig. 3, the condenser C should have a capacity of approximately 0.0005 mfd. The coil L consists of approximately 50 turns of No. 20 double-cotton-covered wire, wound with a tap at 25 turns on a 2½-inch diameter tube. A 112A-type tube is used in connection with a 25-watt lamp D.

In Fig. 4, the condenser C should have a capacity of approximately 0.0004 mfd. The coil L<sub>1</sub> consists of approximately 100 turns of No. 22 enamelled wire wound with a tap at 50 turns on a 1¾-inch diameter tube. The coil L<sub>2</sub> consists of 100 turns of No. 28 enamelled wire, wound on a 1¼-inch diameter tube. These coils, if placed close to each other, should have their axes at right angles; that is, one should be mounted vertically and the other horizontally. A 201A-type tube is used in connection with a 25-watt lamp D.

When used on a 110-volt line, these oscillators will give an adequate signal for all ordinary testing purposes. If the supply is from a direct-current line, the signal generated will be a pure unmodulated high-frequency signal. If, however, the supply is from an alternating-current line, the signal will be a high-frequency signal modulated by the line frequency—60 cycles in most cases. This 60-cycle signal will be audible in the loud speaker of the radio set, but no sound will ordinarily be heard from the oscillator signal if the oscillator is operated on direct current.

### An SOS to the Established Serviceman

With the exception of those working in a few very large cities, the serviceman in the employ of a radio dealer is underpaid. His salary averages between \$20.00 and \$25.00 per week. On the other hand, there is the independent serviceman who, generally starting with radio as a sideline, has worked up a clientele, and perhaps services for several different dealers. He collects a good commission on all parts used for replacement and nets a reasonably good living, often in excess of \$50.00 a week.

It is difficult to start one's own service business, but good servicemen are doing it everywhere. In many cases they have

supplemented their own independent business with contract work for dealers who are glad to be relieved of the necessity of maintaining their own service department. This is an advantage to the dealer, and certainly of value to the independent service organization. The arrangement often goes further than mere service, because a large number of service calls indicate the possibility of set or tube sales, and many who have a commission arrangement with the dealer on such sales as may be closed through leads furnished by them, are able to realize an income on selling in which they have responsibility.

What have our readers done in this respect? Perhaps the manner in which you solved your own servicing problems will be of vital assistance to some other serviceman sitting on the fence. Do you or do you not service for dealers? If you service for dealers, what are the terms of your contract?

How did your service start? What were the selling arguments you used in closing contracts with local dealers, and were these dealers making a profit, as far as you can determine, from their service departments? Did they prefer to have their service work done on contract because it was not possible for each individual dealer to secure a high-grade serviceman to do their individual work, or was the contract signed because of economies which you were able to effect for the dealer?

We are particularly interested in how you closed with the first dealer and the conditions leading up to this point. Do you operate from a central point with your own office, laboratory, and workrooms, or how is this done?

We are interested to know the methods by which dealers requiring service work turn over the orders to your organization. How many men do you employ? What is your scale of charges? How are collections from the ultimate customer made—by your organization or is the customer billed by the dealer whose work you do? Do you grant a commission on gross service charges to the dealers referring business to you or what is the arrangement? How does your scale of wages for servicemen compare with that paid by local dealers who are doing this work as part of their own retail organization?

It would be of interest to know what kind of service equipment you use: whether your set analyzers are purchased complete from one of the several manufacturers, or whether you use devices designed and built by yourself. How many of these analyzers are employed?

What proportion of repair work is done in the customer's home and what in your shop?

Your answers to these questions will be appreciated by fellow servicemen, and paid for by RADIO BROADCAST.

#### *An Interesting Booklet*

Under the title of "Fixed Resistor Replacement Problems," the International Resistance Company, 2006 Chestnut Street, Philadelphia, Pa., has published an interesting booklet on the resistor requirements of modern broadcast receivers. The text covers the importance of good resistors, their power carrying capacity, the noise factor, and how to determine the necessary resistance and current handling capacity required.

#### *A Legal Question*

The Radio Service Managers Association, with headquarters at 324 West 42nd Street, New York City, is gradually getting into swing. This is an organization with a membership made up of service managers and servicemen, providing a  
(Continued on page 345)

**"We found over a period of two years that CeCo Tubes were the most profitable to handle in more than one way."**

*Albert A. List, List Brothers, Distributors, Fall River, Mass.*

**"Give me any radio serviceman. Let him spend two hours alone in our 3½ acre plant... seeing for himself why million dollar equipment and 42 engineers are needed to make CeCo a decidedly better tube. Then—when he makes his next service call...there'll be a new set of CeCo Tubes installed."**

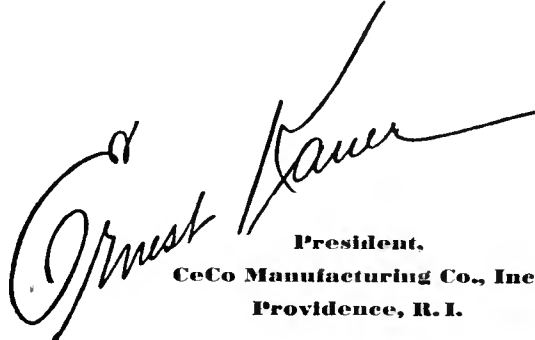
  
**Ernest Bauer**  
 President,  
 CeCo Manufacturing Co., Inc.  
 Providence, R. I.

### **DO YOU KNOW?**

1. Over 10,000,000 CeCo Tubes are in use today. The U. S. Government, ocean steamships, and countless commercial organizations are daily users of CeCo Tubes.

2. In the last 5 years CeCo has outgrown two sizable factories and now has the largest and most modern plant devoted exclusively to manufacturing of radio tubes.

The CeCo Couriers broadcast every Monday night at 8:30 P. M. Eastern Standard Time over the Columbia Chain from 22 stations. Listen in next Monday.

CeCo Tubes are licensed under the patents and applications of the Radio Corp. of America, General Electric Co., Westinghouse Electric and Mfg. Co. and Associated Cos.

**CeCo**

**1930  
Radio Tubes**



BREMER TULLY MODELS S-81 AND S-82

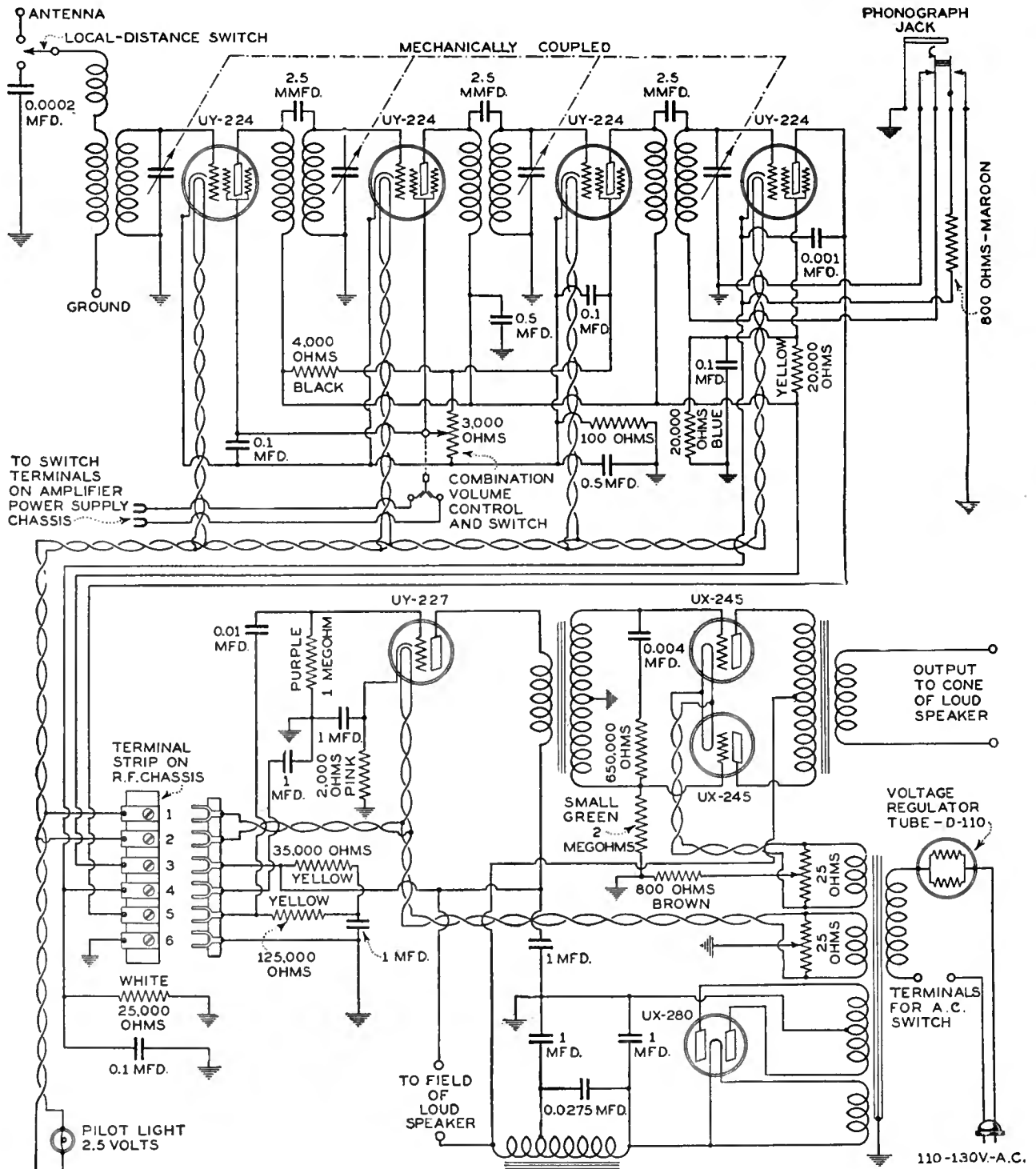

THE CHASSIS used in the Models S-81 and S-82 receivers is designed for the new a.c. screen-grid tubes. The radio-frequency circuit consists of three stages of tuned and shielded high-gain amplification using the a.c. heater-type screen-grid tubes (224). By the use of localized shielding and proper grounding (each rotor section of the tandem condenser assembly is individually grounded even though the rotors are electrically connected in a common grounded steel shaft) the chassis and tubes are made accessible and are unencumbered by unnecessary shielding. All wiring is rigidly secured in position under the automobile-type steel chassis and protected from interstage reaction by the use of secondary aluminum shields. All r.f. coils are matched to a standard and are interchangeable. Volume is controlled by increasing or decreasing the screen-grid voltage. A local-distance switch controls the sensitivity.

The power detector uses the grid-bias method of demodulation instead of the condenser-leak method. This is possible because of the tremendous amplification secured in the radio-

frequency amplifier. The power detector is a screen-grid tube.

The power detector is automatically biased for use as an amplifier for the reproduction of phonograph music when the magnetic pick-up unit is plugged into the jack provided at the rear of the r.f. chassis. Any good high-impedance pick-up unit provided with a volume control may be used.

AVERAGE VOLTAGE READINGS					
Type of Tube	Position of Tube	A Volts	B Volts	C Volts	Normal Plate mA.
227	1st R.F.	2.5	150	12	5.5
227	2nd R.F.	2.5	150	12	5.5
227	3rd R.F.	2.5	150	12	5.5
227	Detector	2.5	45	0	3.4
227	1st A. F.	2.5	145	9	3.6
245	1st P-P	2.4	240	27	30.0
245	2nd P-P	2.4	240	27	30.0
280	Rectifier	5.0			
D98	Ballast				

The audio-frequency amplifier consists of two stages. The first stage of amplification is resistance coupled to the detector tube, and employs a heater-type tube of the 227 type. The power amplifier employs two 245-type tubes in a push-pull amplifier circuit. All amplifying tubes and the detector tube have automatic grid-bias control which compensates differences in current drain from the rectifier system.

The power pack supplies all required voltages to the seven receiving tubes and energy for the field of the electrodynamic loud speaker. The Duresite type No. 110 voltage-regulator tube maintains a constant voltage across the primary of the power transformer, and protects the other tubes in the receiver from line voltage changes between 98 and 130 volts.

The direct current filter system is tuned to remove all trace of a.c. ripple. The loud speaker field acts as an additional choke in the filter system, and also furnishes the necessary resistance to reduce the high voltage for the two 245 tubes to the correct value for the r.f. and a.f. amplifier tubes.

(Continued from page 343)

rating for the latter, by examination, which, when the organization gains recognition, may be of significance.

The organization publishes *The Radio Service Man*, which is sent only to members. It is suggested that servicemen interested in joining, communicate with the association. The dues for the grade of membership in which the average reader will be interested are \$5.00 per year with a \$2.00 initiation fee.

The January issue of *The Radio Service Man* presents an interesting problem:

"A customer resides in a home not equipped with base outlets. She has been given to understand by the salesman that the set will be installed.

"She shows the installer where the set is to be installed. (Fifty feet from the nearest current source.)

"He explains to her the advantages of locating near the current supply, calling to her attention the fire rules regarding same.

"The customer refuses to change her mind and the serviceman has her call the shop.

"In some cases the policy is to install no matter how. The shop tells the man to go ahead.

"O. K.," says he, taking from his bag eight feet of lamp cord and adding to this No. 18 rubber 'plated' lead-in wire, (twisted as well as possible).

"There are many cases where men don't even go through the preliminary of calling the office.

"Reaching for the chandelier he lets down the canopy and makes an unsoldered wrap splice. In retaping the splice he neglects to use rubber tape, substituting ordinary friction.

"Now just suppose this wiring acquired a partial short and caused a fire.

"The New York Fire Department code limits the length of this wire to 12 feet.

"The insurance companies state explicitly in their policies that all wiring must conform with existing regulations regarding same.

"Who pays?"

"We are not lawyers and don't attempt the answer, however we feel that there is food for thought in the foregoing."

### More "Dope" on Noise

Seventy-five per cent. of all contributions to "The Serviceman's Corner" are concerned with the elimination of noise in one form or another. This is probably sig-

nificant of the extent to which this trouble is prevalent in the category of radio difficulties. The possibilities of noise were analyzed in considerable detail in the "Corner" for January, 1930. The following contributions may be considered supplementary to this "Symposium."

#### HUM IN RADIOLAS

"I have found from extensive experiments on Radiola 44 and 45 receivers, that the hum can be reduced by connecting an 0.5-mfd. condenser from terminal No. 6 on the socket-power unit (the maroon colored wire) to the common ground. This doubles the capacity across the detector cathode, and does the trick.

"The Radiola 66 receiver can also be improved upon in this respect. Add an 0.25-mfd. condenser across the 220-ohm reactor coil (the choke nearest the 280) by connecting one lead from the condenser to one terminal of the 280 filament lead and the other to the midtap of the two chokes." (The center tap on the 280 filament winding is to be preferred to one leg of the filament.—Ed.)

A. J. BARRON, Radiotrician and Electrician, Shawnee, Oklahoma.

#### THE VICTOR HUMS

IL. W. HUDELSON, Auto and Radio Service, Vandalia, Mo., a veteran contributor to the "Corner," lends us a hand here.

"We find that the Victor is hard to fit with a humless 27-type detector tube, and even when we succeed in getting a good tube, with the hum considerably reduced by means of the hum adjuster, another source of trouble is often in evidence. The next thing to do is to throw on the phonograph switch, cutting out the chassis, and adjust the hum control on the amplifier. If this does not eliminate the hum, pull out the chassis and power unit, and resolder all connections, regardless of how secure they may appear. Hold the iron on the joint until every bit of resin has been driven out. This cures the hum in about 99 cases out of a hundred."

(Offhand it is difficult to justify this cure. But we accept it on its face value from an expert with Victors.)

#### THE POWER PACK IS GUILTY

"When the metal casing is off the power pack of some of these compact electric sets, so the pack can be tested with the set in operation, a pronounced hum is present in the output. This is usually due to coupling between the rectifier and the detector tubes, which can be reduced

by placing a small grounded metal sheet between these tubes, or by covering the rectifier with a shield. In sets having the rectifier in the open it may pay to shield this tube permanently."

CLAUDE AUSTIN, Austin Radio Service Portland, Oregon.

#### THE POWER AMPLIFIER

"I recently had some very unusual experiences with a power amplifier that I believe will help some of the readers of the 'Corner.'

"The amplifier in question developed a terrible crackling sound, very similar to static, and a check on all tubes showed them to be in first-class condition. This amplifier, employing a 227-type tube in the first stage and two 210-type tubes in push pull as the final stage, was used with a superheterodyne receiver and was equipped with a switch to connect the input to either the radio or an electric phonograph pick-up.

"This crackling noise showed itself only when the radio set was connected to the amplifier and this would, naturally, indicate that the trouble was in the radio set itself. However, a thorough test of every tube and part in the set placed the trouble in some other section. This seemed illogical in view of the fact that the amplifier performed satisfactorily when the electric pick-up was being used.

"As a last resort I suspected the first stage a.f. amplifier, although nothing seemed to indicate such might be the case. A new transformer was tried and the trouble disappeared. Just why the transformer was noisy on the radio set and not on the pick-up is still a mystery to me."

CHAS. H. JENKINS, JR., Radio Service

Since 1914, Audubon, N. J.

(A carrier wave sensitizes a set to disturbances in any part of the system.—Ed.)

J. NOONAN sends along a few corroboratory lines: "A case of interference manifested itself in a peculiar grating sound which seemed to keep time with the music received. The receiver was tested several times and no trouble could be found. The difficulty was finally located in a lamp which was on the top of the set. The lamp was a two-candle affair, with two shades which were suspended from metal brackets. The vibrations from the electrodynamic loud speaker set the two shades swinging. The shades rubbing on the metal standards generated static discharges which were quite easily heard in the receiver."

## THE INVESTOR LOOKS AT RADIO

(Continued from page 329)

and Kolster, the passing of the dividend of Brunswick-Balke-Collender, and the withdrawal of Eveready from manufacturing are indicative of the general situation in the industry. If large inventories are written off, it is probable that earnings of most companies for 1929 will be considerably below those for 1928. At this writing few reports have been published but a report from Crosley showed actual and per share earnings for 1929 less than one third those for 1928.

One of the most hopeful new developments is the use of vacuum tubes for purposes other than radio receiving and transmitting. These tubes are essential in telephone and telegraph systems; in the production and reproduction of talking pictures; in the metering of gas and electricity; in detection of flaws in metal; in the matching of color; in the practice of light therapy in medicine, and in the chemical industry. New developments are constantly

taking place but it is probable that the profits derived from all these minor uses will not equal those derived from the sale of receiving apparatus for many years.

The immediate prospects for the industry appear, therefore, to be for lower earnings, with a probable consolidation or elimination of some of the weaker companies in the field. Over a period of years, the outlook is much more promising but before real progress can be made disposal must be made of surplus stocks and the industry as a whole, placed on a firm financial basis. It is a practical certainty that a number of the stronger companies will survive and for them earnings will show a normal increase over a period of years, but it is still too early to speculate on the outcome of some of the weaker companies in the field, especially when total income is dependent on radio production. In a succeeding article we shall outline the position of the Radio Cor-

poration of America, giving reasons why we think it more attractive than some others for long-term holding, and in subsequent articles, we shall discuss other companies whose securities appear fairly priced, but in general, we should use the greatest discrimination in buying stocks of radio companies unless the purchaser knows them to be more favorably situated than the average.

### Asks Wavelength For Ship-to-Shore Phone

Predicting a growth in two-way radio telephone between ship and shore, Frank B. Jewett, president of the Bell Telephone Laboratories urged the Commission to set aside a block of 48 frequencies for such service. He recommended that channels for different services be grouped in blocks rather than staggered throughout the spectrum as at present.

# GREBE SK-4 SUPER-SYNCHROPHASE RECEIVER

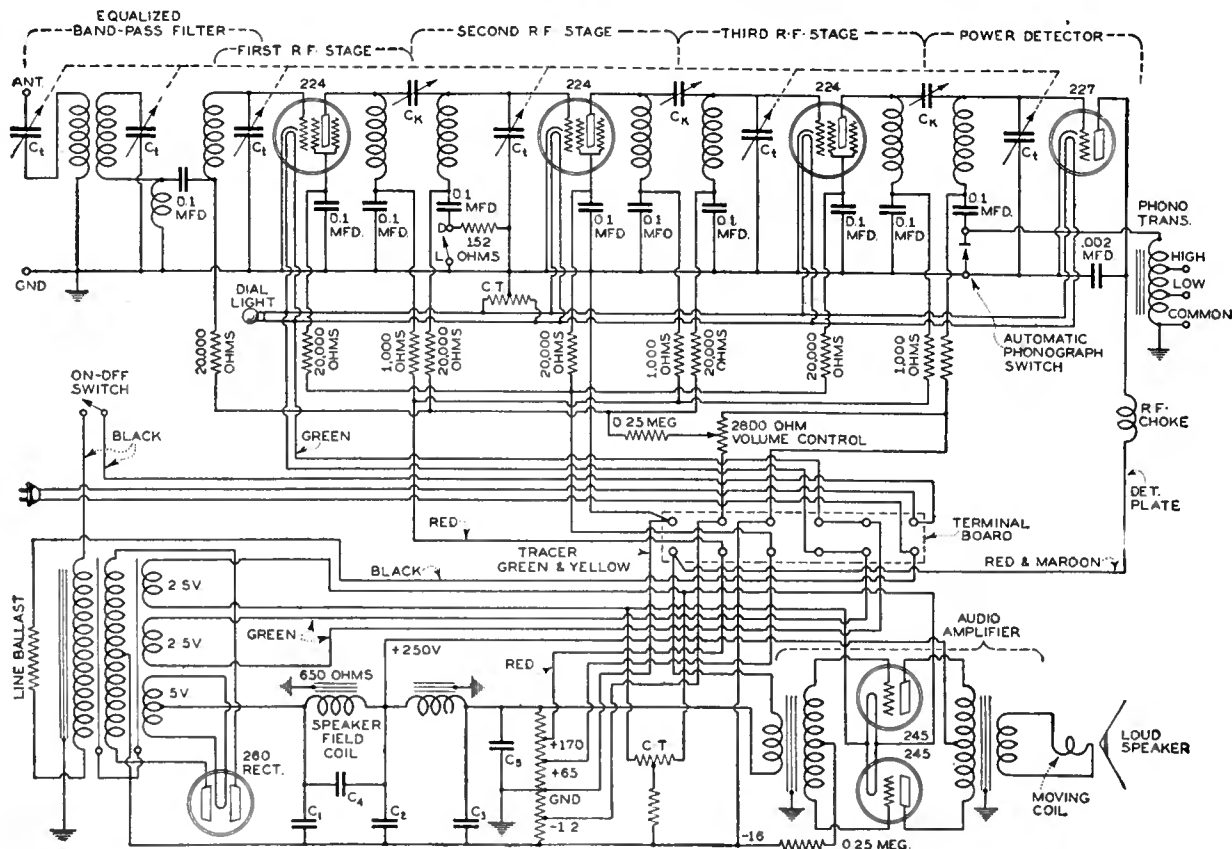

This receiver consists of a three-stage screen-grid r.f. amplifier, a type 227 detector, and a push-pull output stage using two 245-type tubes supplying power to an electrodynamic loud speaker. The receiver contains several unusual features.

signal voltage from the secondary of the a.f. transformer, the primary of which is connected in the plate circuit of the detector tube. Since push-pull amplifiers sometimes have a tendency to oscillate, a 1/2-megohm resistor is connected in

series with the center tap of the secondary of the transformer. This resistor prevents the circuit from oscillating but has no effect on the audio-frequency characteristics of the amplifier.

### R.F. Amplifier

Preceding the first screen-grid radio-frequency amplifier tube is a band-pass filter circuit consisting of two tuned circuits coupled by both capacity and inductance. Tuning condensers associated with these band-pass circuits are marked Ct on the diagram and these circuits function to prevent any signals other than those from the desired station from being impressed on the grid of the first r.f. amplifier tube. Highly selective circuits of this type are used, especially in connection with the screen-grid r.f. amplifiers, because these tubes tend to produce cross-talk. Cross-talk is eliminated if the circuits preceding the first tube are sufficiently selective to prevent practically all signals other than the one desired from being impressed on the first tube. To obtain this high selectivity simple tuned circuits might be used but these would produce sideband suppression. By the use of band-pass circuits, high selectivity without sideband suppression is obtained.

### Impedance Coupling

The following tubes in the r.f. amplifier are impedance coupled, that is, a tuned circuit is in the plate circuit of each tube. The plates are choke fed and the tubes are coupled to the tuned circuits through small adjustable condensers, Ck. The condensers are, of course, properly adjusted at the factory and need only be altered in the event that the set has been altered due to rough handling.

### Detector Circuit

The detector, using a 227-type tube, is of the plate-detection type. In the grid circuit of the detector tube a phonograph pick-up transformer is connected with two taps to make it suitable for use with either low- or high-impedance pick-up units. In normal operation as a radio receiver this transformer is shorted out of the circuit by the phonograph switch. When the set is to be used with a phonograph pick-up unit this switch is opened and the phonograph pick-up transformer is thereby connected in series with the grid circuit of the detector.

### A.F. Amplifier

The two 245-type power tubes obtain a.f.

READINGS WITH WESTON SET TESTER MODEL 547

Type Tube	Tube Position	A Volts	B Volts	C Volts	Screen Volts	Screen Current	Cathode Volts	Normal mA.	Grid Test mA.
224	1 R.F.	2.4	155	0.2	38	0.5		2.8	32.0
224	2 R.F.	2.4	150	0.2	38	0.5		2.8	3.0
224	3 R.F.	2.4	150	0.2	38	0.5		2.8	3.5
227	Det.	2.4	180					0.5	1.4
245	P. P.	2.4	225	*				37.0	42.0
245	P. P.	2.4	225	*				37.0	42.0
280	Rect.	4.9							50.0 per anode

Line Voltage = 116

\*No bias reading at socket due to resistance in series with grid.

Bias can be read with voltmeter lead connected between filament and chassis.

READINGS WITH JEWELL SET ANALYZER MODEL 198

Readings with Plug in Socket of Set and Tube in Tester

Type of Tube	Position of Tube	Tube Out A Volts	Tube Out B Volts	A Volts	B Volts	C Volts	Cathode Heater Volts	Normal Plate Volts	Plate Grid Test	Plate mA.	Plate Change mA.	Screen Grid Volts
224	1 R.F.	2.7	195	2.35	188	14		0	2.0	2		57
224	2 R.F.	2.7	195	2.35	188	14		0	2.0	2		57
224	3 R.F.	2.7	195	2.35	188	14		0	2.0	2		57
227	Det.	2.7	195	2.35	210	x		0.8	0.8	0		
245	1 A.F.	2.7	270	2.35	245	x		30.0	34.0	4		
245	2 A.F.	2.7	270	2.35	245	x		30.0	34.0	4		
280	Rect.	7.0		5.2		x		90.0				

Line Voltage = 120. Volume control position Min.\*

Note: x Resistors in circuit prevent readings.

Note: \*224 plate current read with volume control at maximum position.

READINGS WITH A SUPREME RADIO DIAGNOMETER

Type Tube	Tube Position	A Volts	B Volts	C Volts	Screen Volts	Normal mA.
224	1 R.F.	2.4	155	0.2	38	2.8
224	2 R.F.	2.4	150	0.2	38	2.8
224	3 R.F.	2.4	150	0.2	38	2.8
227	Det.	2.4	180			1.5
245	P. P.	2.4	225	*		37.0
245	P. P.	2.4	225	*		37.0
280	Rect.	4.9				50.0

Line Voltage = 116

\*No bias reading at socket due to resistance in series with grid. Bias read with voltmeter lead connected between filament and chassis.

## MEASUREMENTS OF H. F. RESPONSE

(Continued from page 314)

kilocycles at which a normal output of 50 milliwatts is obtained at 10 and 100 times the resonant amplitude for normal output.

It will be observed that none of the one-audio-stage sets or none of the sets employing a low-gain, two-stage, audio-frequency amplifier shows appreciably better low-frequency response than the sets employing two high-gain, transformer-coupled, audio-frequency stages. Less hum is obtained, to be sure, but no great improvement is noted in low-frequency response. In other words, the design of the audio-frequency amplifier in these receivers is in essence very much the same, although it might be expected that, since only one a.f. transformer is employed, and the squaring action of deficiencies occurring in two transformer stages is absent, a much better frequency characteristic would be obtained.

This is substantiated by an examination of the high-frequency end of the fidelity curves for 1200 kc. These curves represent, as stated above, the frequency characteristics of the a.f. amplifiers in the respective receivers. With two exceptions, namely Figs. 3 and 4, the high-frequency response of the sets employing two transformer-coupled stages and grid-leak detection, is practically as good as that in receivers employing one audio-frequency stage or two low-gain stages and C-bias detection. It would appear, therefore, that the maximum possibilities of one-stage, audio-frequency amplifiers, or low-gain, audio-frequency amplifiers have not been exploited as yet in most recent receivers. These possibilities, so far as high-frequency response of the audio-frequency system itself is concerned, are illustrated by the 1200-kc. fidelity curve of Fig. 4.

A glance at most of these fidelity curves shows that, whereas a response of anywhere from 50-80 per cent. is generally obtained at 100 cycles, and 30-50 per cent. at 60 cycles, the transmission at 3000 cycles is only of the average order of 20 per cent. In fact, in some instances 4000- and 5000-cycles transmission is of a negligible order. If this deficiency were due only to poor audio-frequency response the difficulty could be resolved very quickly. But even with a very good high-frequency response in the audio-frequency end, as in Fig. 4, the fidelity at 600 kc. is very poor at the high frequencies.

### Sideband Suppression

The primary source of high-frequency loss is in sideband suppression due to sharpness of resonance. This is all the more noticeable when the straight audio-frequency characteristics of the set are very good, as in Fig. 4. But even when the audio-frequency characteristics are not of the best, as in Figs. 1 and 7, there is considerable high-frequency loss as shown by the difference in the 1200-, and 600-kilocycle fidelity curves. The severity of sideband suppression is illustrated in any of the attached curves, which show that suppression starts as low as 1000 cycles.

Sideband suppression may be very bad even in receivers which do not have a very high degree of selectivity. Thus Fig. 3 illustrates a receiver with exceptionally fine audio-frequency characteristics. Its selectivity, as shown by the band widths, is not all that can be expected of a four-tuned-circuit set. Nevertheless, the 600-kc. fidelity curve shows very noticeable drop in high-frequency response. However, even with this loss its high frequency response is very good. This illustrates that the only way to retain good high-frequency response even with sidebands cut off

is to start out initially with an abundance of these frequencies, as in this receiver.

The degree to which the 1200-kc. and 600-kc. fidelity curves depart is not always a measure of the degree of sideband suppression, and therefore of sharpness of resonance. Thus, Fig. 4 illustrates a receiver with very good high-frequency characteristics and a very marked amount of high-frequency cut-off due to sideband suppression. The 1200- and 600-kc. curves are very wide apart. Figs. 1 and 7, on the other hand, illustrate receivers with approximately the same high-frequency response at 600 kc., these receivers differing appreciably in selectivity. While a great deal of sideband suppression is present, most of the loss in these sets occurs in the audio-frequency system, and consequently the 1200-kc. and 600-kc. fidelity curves for each set are closer together.

### Selectivity vs Suppression

It is of interest to note that two receivers having approximately the same selectivity, as expressed by the figure of merit advocated by the proposed I. R. E. standards and indicated for each receiver on its curve sheet, do not necessarily show the same degree of sideband suppression. Thus sets 4 and 5 have approximately the same band widths at 600 kc., yet the former shows markedly more sideband suppression than the latter. This is because receiver 4 is much sharper than receiver 5 at or very near resonance, whereas off resonance they both show nearly the same selectivity characteristics. This difference is probably due to the use of an extra tuned stage in receiver 5, each stage being broadly tuned and the overall resonance curve being flat at resonance and sharp off resonance.

It might be stated that in spite of the noticeable lack of high frequencies, these receivers sound very good. While this is true in some cases the sets would sound immeasurably better if they reproduced the high frequencies to a greater extent. When they do sound good it is probably due to a considerable amount of compensation introduced by the loud speaker which reproduces the high frequencies better than the low frequencies. As often as not, however, the sets do not sound so good, especially when the loud speaker is not efficient at high frequencies. As one distributor of radio sets put it, "Radio sets are made so that a canary bird sings bass."

Unfortunately the strict selectivity requirements imposed upon radio receivers necessitates sharp resonance characteristics with resultant high-frequency suppression. Until band-pass filters with square-top resonance curves and sharp cut-off are better developed it seems that the only way to secure the higher frequencies is to design the audio-frequency system with rising characteristics or introduce the necessary compensation in the loud speaker.

The one strong objection most frequently heard against real good high-frequency response is the introduction of excessive noise and tube hiss, the high-frequency components of which are predominant. For loud signals, where the amplification of the receiver can be considerably reduced, this is not at all important. This objection is valid wherever weak signals are concerned, but in such cases reception cannot be very entertaining, to say the least, and it seems wrong to have to penalize radio sets in the way of high-quality reproduction in order to eliminate noise arising in distant reception.

The reader may be interested to know that the curves which accompany this article were made from actual measurements on standard radio receivers taken directly from stock.

## TESTING INSTRUCTIONS

### FOR SERVICE MEN



For use with

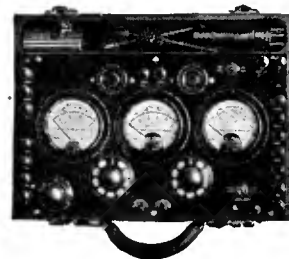

Model 547

## RADIO SET TESTER

This Instrument, and this Manual which is furnished with it, together provide the most complete and up-to-date equipment available for servicing radio receivers. Electrical data for practically every set on the market is contained in this book—which is made up in loose-leaf form so that purchasers of the instrument who turn in registration cards are automatically supplied with latest information.

This instrument has achieved wide success among dealers and service men. It is preferred because of its dependability, ingenious design providing ease of operation, compactness and light-weight portability. It will make all the required tests on any A. C. or D. C. set. Durable bakelite case and fittings. Provided with 3 1/4" diameter instruments.

  
WESTON ELECTRICAL  
INSTRUMENT CORPORATION  
604 Frelinghuysen Ave. Newark, N. J.



### THE BALKETT MODEL C

An interesting feature of this receiver is the use of double primaries on all of the radio-frequency transformers. In all cases the two primary windings are connected in series and an 0.00025-mfd. fixed condenser is connected across one of the primaries. These two windings are used to

obtain uniform r.f. gain over the entire broadcast band, the capacity shunted winding being most effective at low radio frequencies and the unshunted winding being most effective at high radio frequencies, thus the inefficiency of each winding is compensated by the other.

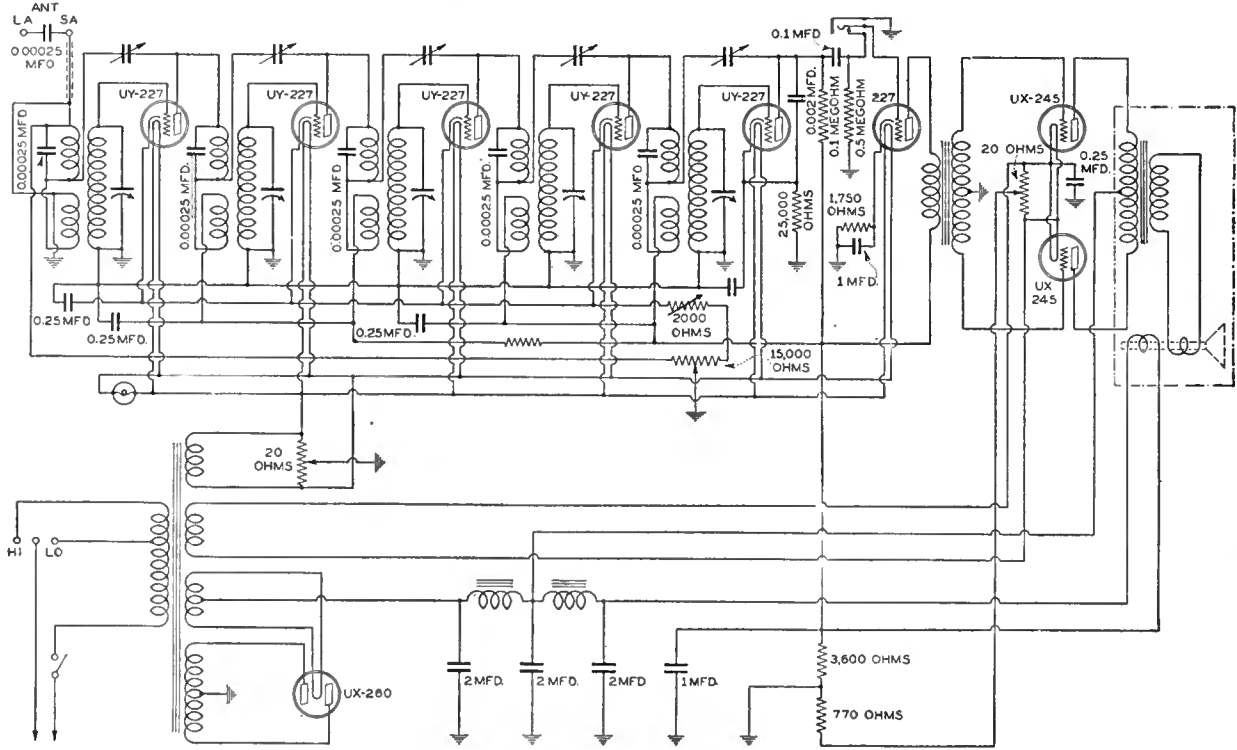

### THE KENNEDY CHASSIS NO 10

This is a screen-grid receiver using three 224-type tubes as r.f. amplifiers followed by a C-bias detector, one resistance-coupled a.f. stage, and one transformer-coupled a.f. stage. Note the r.f. filter in the detector

output consisting of an r.f. choke and two fixed condensers, such a filter being essential when the detector is resistance coupled to the following amplifier tube.

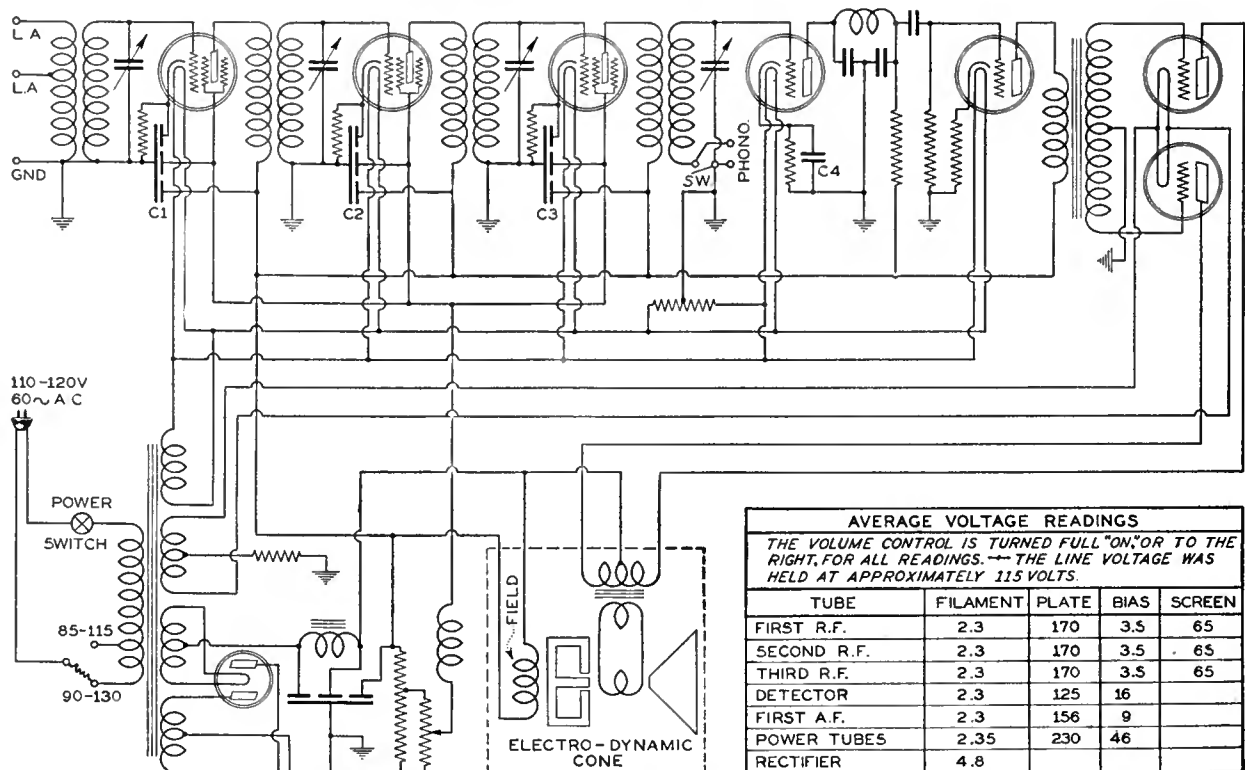

AVERAGE VOLTAGE READINGS				
THE VOLUME CONTROL IS TURNED FULL "ON," OR TO THE RIGHT, FOR ALL READINGS. — THE LINE VOLTAGE WAS HELD AT APPROXIMATELY 115 VOLTS.				
TUBE	FILAMENT	PLATE	BIAS	SCREEN
FIRST R.F.	2.3	170	3.5	65
SECOND R.F.	2.3	170	3.5	65
THIRD R.F.	2.3	170	3.5	65
DETECTOR	2.3	125	16	
FIRST A.F.	2.3	156	9	
POWER TUBES	2.35	230	46	
RECTIFIER	4.8			

## BAND-PASS FILTER CIRCUITS

(Continued from page 328)

The loss of amplification due to the use of an extra filter is considerably greater than 50 per cent. The variation in selectivity, however, is now only in the ratio of 2.6-1, and it has been increased to about three times at the lower frequency; the sideband variation at this frequency is about the same, but at 1200 kc. it has been reduced to 15 per cent.

It is doubtful whether the extra selectivity is justified in view of the loss of amplification which accompanies it, particularly as the selectivity with only the single filter and two tuned plate circuits is fairly high. It can be seen, however, that the capacitatively coupled filter enables a very great increase in selectivity to be made at the higher frequencies without increasing the sideband variation at the lower frequencies. Indeed, by the use of suitably designed capacitatively coupled filters for all the tuning circuits in a receiver, it would be possible to make a receiver with constant selectivity throughout the whole broadcast band. This would be quite impossible with inductive coupling.

### Other Advantages

From the foregoing it will be seen that the use of capacitatively coupled filters in place of the usual cascade tuned circuits allows, not only of greater fidelity, but also of greater selectivity at the higher broadcast frequencies. While inductive coupling permits the retention of sidebands, it does nothing to correct the low selectivity at high frequencies.

Another advantage is gained by the use of filter circuits instead of cascade circuits; it becomes somewhat easier to obtain satisfactory linking up of the variable condensers. The effect of misalignment with cascade circuits is a loss of amplification and selectivity. With filter circuits the effect is rather different. Misalignment causes the tuning curve to become asymmetrical; consequently, the selectivity becomes greater on one side of resonance than on the other. Indeed, the selectivity on one side may become greater than that with perfect alignment. Owing to the flat topped curve, a slight amount of misalignment does not appreciably affect the amplification. Perfect alignment, of course, is just as difficult to obtain with band-pass filters as with cascade circuits, but the effects of slight misalignment are not usually so serious.

## STRAYS FROM THE LABORATORY

(Continued from page 333)

curves were somewhat incorrect. The lowest section of the logarithmic ordinates of the selectivity curve, Fig. 1, was contracted—a correct curve will be found in Fig. 3. In the case of the fidelity curve, the point on the abscissa marked 80 cycles should have been marked 30 cycles. If this change is made the fidelity curve is correct.

### Pentode Articles

The following articles and notes on the Pentode tube may be of interest. They all appeared in RADIO BROADCAST.

November 1928, Henney "New Trends in Radio 1929-30."

April 1929, "Strays from the Laboratory," "Characteristics of Philips Pentodes."

July 1929, "Strays from the Laboratory," "Characteristics of Mullard Pentode tubes."

October 1929, "Strays from the Labora-

tory," "Output from Pentodes Using Igramic Output Transformers."

October 1929, Cocking, "Possibilities of the Pentode Tube."

December 1929, Roth, "Development of the Pentode Tube."

March 1930, Henney and Rhodes, "Characteristics of Pentodes."

### T.R.F. Articles

A list of articles dealing with the tuned-radio-frequency amplifier which have appeared in the I.R.E. *Proceedings* is given below.

"The Shielded Neutrodyne Receiver" by L. A. Hazeltine, June 1926.

"Method of Maximization in Circuit Calculation" by Walter Van B. Roberts, October 1926.

"Selectivity of Tuned-Radio-Frequency Receivers" by K. W. Jarvis, May 1927.

"Mathematical Study of Radio-Frequency Amplifiers" by Victor G. Smith, June 1927.

## THE MARCH OF RADIO

Continued from Page 317

profit. In other words, with 25 per cent. of its time sold, the Columbia system succeeds in breaking even.

Bookkeeping methods have a lot to do with how an annual statement comes out. However, in the case of the N. B. C. it is difficult to see, under the circumstances, how it can help but show a very substantial profit, in spite of its lavish use of high-priced space and such luxuries as Schumann-Heink's services as operatic counsel.

The N. B. C. could, if it would, perform a great service to the public by soft pedaling the blatant advertising in practically every program broadcast during the choice evening hours. Addressing the advisory committee, which meets once a year to hear Mr. Aylesworth's accounting of his stewardship, the president of the N. B. C. reported a gross revenue of \$15,000,000 during 1929. The personnel of the company increased from 558 to 917, and clients from 96 to 199. The permanent network involves 32,500 miles of telephone lines, linking 73 stations. The outlet stations concentrate almost entirely on presenting advertising features and this probably accounts for the recent reduction of 50 per cent. in the charges made for sustaining programs.

Evidently the advertising profession has accepted radio and therefore the custodians of the medium can, if they will, do a little housecleaning before the public refuses to listen to the spoken word over the air. The courageous act of publicly throwing somebody off the air (especially if there is a customer waiting to step in for the particular hour involved) would effect a salutary warning to the advertising profession. The entertainment value of broadcasting and, in consequence, the effectiveness of program sponsorship and the sales of radio receivers would be markedly stimulated if advertising announcements were restricted to ten seconds, once each ten minutes. No one would bother to tune out short announcements.

The present policy of radio advertising is to say more and more to fewer and fewer. The more intelligent policy would be to say less words of greater effectiveness to the greatest possible number. The painful thing about radio advertising is the growing length of the advertising dose handed out with each announcement. The public does not react unfavorably to a few words of the most direct kind of advertising. The loudest groans are caused by the tediously long announcements which are now the custom.

## Just Out . . . Keith Henney's Book on Radio

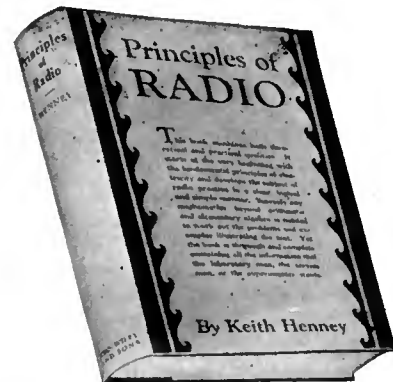

## Principles of Radio

By KEITH HENNEY

Director of the Laboratory  
Radio Broadcast Magazine

Readers of Radio Broadcast, long familiar with the work of Keith Henney in his capacity as Director of the Magazine's Laboratory, will be eager to secure his first book, just released from the press.

This book brings together within one cover the kind of information on radio which will appeal to the practical interest of every radio experimenter, technician, engineer, and fan. It contains the latest data and the most modern methods. It treats in a thoroughly practical way everything from the production of radio currents to their reception and transmission. Many problems, examples, illustrations, experiments, are here presented in book form for the first time.

Keith Henney, by reason of his wide experience as an operator, engineer, and writer, has the gift of making technical information readily understood by the reader.

See a Copy on Ten Days'  
Approval

Price \$3.50

## A Wiley Book

ON APPROVAL COUPON

JOIN WILEY & SONS, INC.  
440 Fourth Ave., New York City

RB 4-30

Gentlemen: Kindly send me on approval Henney's "Principles of Radio." I agree to remit the price (\$3.50) within ten days after its receipt or return the book postpaid.

Name .....

Address .....

Reference .....

# RADIO

## TUBE MAKERS DEFEND THE PENTODE

Three tube makers in the United States have offered pentode tubes. They are Areturus, Champion, and CeCo. Tubes of the first two companies are power tubes to be used only as audio-frequency amplifiers. The CeCo tube is designed for radio-frequency amplification. We are glad to present here statements from two of the companies on this much-discussed pentode question.

—THE EDITOR.

By JASPER MARSH

Treasurer, Champion Radio Tube Company

The new type of pentode now being developed in this country is new. There is as much difference between the continent pentode and American pentode as there is between the UX-171A and the UX-250. The tube as it now stands is surely an engineering advance for the improvement of the art.

It is very easy to conceive a real power detector which will work directly into the loud speaker. It would make possible a real portable set, better radio sets for automotive uses, and cut the cost of operation considerably. Experimental work that has been done along these lines with the pentode tube proves that all these uses are quite feasible.

How the uniformity of pentodes will run is not known at the present time. If we care to take the English tube and compare its cost with their power tube similar to our UX-245, we will find them almost the same.

The single pentode has been used in the laboratory here and the hum from a standard filter such as used in the average receiver does not become any more noticeable than when using two 245-type tubes in push pull. As the  $E_p-I_p$  curve is almost perfectly flat a very small filter could be used in the plate supply. However, at the same time we must think of the ripple in the drop wire from which we obtain our bias. We do not believe any great trouble should be expected from this source, when using an average present-day filter.

As the load impedance for best operations is not taken as twice the tube impedance, as in the case of triodes, but  $\frac{2}{3}$  or  $\frac{1}{2}$  of the plate impedance, the cost of a very high-impedance transformer does not have to be considered and the output device would compare very favorably with that now used for a single UX-245.

In this connection there should also be given consideration to the matter of patent infringements on audio-frequency amplifiers using transformer coupling and push-pull output transformers. The pentode tube can be resistance coupled to the output of a power detector, such as the 224 tube, and hence greatly simplify the audio-frequency system.

Our general belief is that a tube that will deliver 3.5 watts of undistorted power output with a grid swing of 12 volts and a d.c. plate current consumption of 35 mA. at 250 volts, would be quite acceptable by

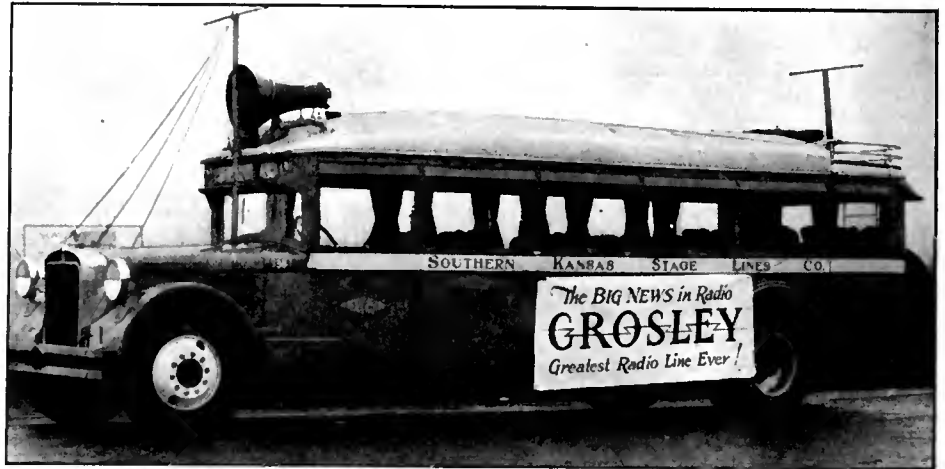

In southern Kansas it is becoming quite common to find motor buses equipped with a radio receiver for the entertainment of passengers. The picture above shows one of a fleet of similarly equipped vehicles.

many set manufacturers for their next model, and it is such people that should not get an unfavorable opinion or report on the tube.

By ERNEST KAUER

President, CeCo Manufacturing Co., Inc.

The response from the press, the trade, and the public over the announcement of the pentode has been most pleasing. The general character of this response evidences no idle curiosity but an expectation and appreciation of the progress in the development of radio science. The crystallization of modern thought to-day evidences an instant desire for constructive improvement.

Radio's increasing development is stimulating more and more thought of its future. The development of the a.c. pentode tube has emphasized in the public mind the fact that radio engineering is made up of two distinct schools—tube engineers and set engineers. The pentode tube has had the effect of establishing the

tube engineers on a status that they have not enjoyed heretofore. In the past, they have been the sort of silent craftsmen who labored in quiet, content to realize their new ideas and take satisfaction in accomplishment.

The entire radio world is indebted to the tube engineers; their researches have done much to make radio reception the glorious satisfaction that it is to-day. There seldom have been any startlingly quick developments in radio tube engineering. All the noteworthy results that are familiar to-day, have come over a period of years of study, application, and much costly effort.

The pentode tube has been in use in Europe for some years as an audio-frequency amplifier for battery-operated receivers. In the research laboratories of the CeCo Manufacturing Company our engineers have added many improvements to the original tube. They are the American pioneers and were the first to adopt the pentode to radio-frequency amplification and audio-frequency amplification for a.c. and d.c. operation. Tube engineers with the pentode and the screen-grid, and in many other instances, have invariably built up an idea which was ultimately used by set engineers. In the past, set engineers have not always been able to develop a receiving circuit which permits the utilization of a tube's full capacities.

The more efficient method seems to be either for tube engineers and set engineers to consult together in advance of a development, or for tube manufacturers to work out a circuit capable of using the full capacity of a new tube. In the latter case, the circuit should be made available to manufacturers of receiving sets without obligation. This last method is the one we have adopted in the case of the pentode. CeCo engineers are now offering to demonstrate to set manufacturers the possibilities of the pentode tubes. Our engineering staff and our engineering facilities are available

(Continued on page 353)

### We Apologize

In an article entitled "Review" on page 251 in March, 1930, RADIO BROADCAST, we carried a report to the effect that the Balkeitt Radio Company was in the hands of receivers. As this issue goes to press we learn that the report was incorrect—Balkeitt was never in bankruptcy. This information was given in good faith as it came from a source which we considered reliable. We deeply regret the error and offer our apologies to the Balkeitt Radio Company.

—THE EDITOR.

## New Broadcasting Company

Two well-known Iowa stations, woc and who have requested the Radio Commission to approve the organization of a new company, the Central Broadcasting Company at Des Moines. This company is capitalized at \$500,000 and will absorb the interests of the Palmer School of Chiropractic, owners of woc, and of the Bankers Life Company, owners of who. It is planned by Dr. Frank Elliott, of woc, to synchronize the two stations by wire, later to erect a 50-kw. transmitter and reduce one of the stations to a regional status. Since 1928, woc and who have been dividing time on the 1000-kc. channel.

## Money for Radio Administration

Late in January, Congress appropriated a total of \$106,000 for the Radio Commission, including salaries of the five commissioners at \$10,000 annually each, and for other authorized expenditures. This sum does not include the entire annual cost of radio administration which is nearly three times this amount.

## Mexican Newspaper of the Air

Each night station XFX, Mexico City, broadcasts news of Mexico both in Spanish and English with 1000 watts on a wavelength of 329.6 meters. The broadcast starts at 11 P.M. Eastern Standard Time. This station uses the service of the Trems Agency, 43 Colon St., Mexico City, and claims it to be the only newspaper of the air in existence. Station XDA at 4 p.m., Eastern Standard Time, using 20 kw. on 21.85 meters, broadcasts Spanish and English news dispatches in continental code.

## Personal Notes

John W. Million, former chief engineer of Bremer-Tully, is now with Utah Radio Products, Chicago, Ill., as research and field engineer.

Vernon W. Collamore, formerly general sales manager for Atwater Kent, is now manager of Radiola Division, RCA-Victor Company, Inc., succeeding E. A. Nicholas resigned.

E. A. Nicholas, former manager, Radiola Division, RCA-Victor Company, has resigned to form his own distributing organization. He will handle Radiolaa and Radiotrons.

D. E. Replogle who recently joined the Jenkins Television Company as assistant to the president, has been made treasurer of that organization.

Fred W. Klingenschmidt, whose name is well known to old-timers in radio, has joined Amy, Aceves & King, New York, as sales manager in charge of installations of the multi-coupler antenna system manufactured and sold by this firm.

Robert H. Stroud has been appointed convention manager, Atwater Kent Manufacturing Co. Mr. Stroud succeeds T. Wayne McDowell, who recently resigned.

G. A. Yanochowski has been elected president of the Kellogg Switchboard and Supply Company, succeeding the late W. L. Jacoby.

M. C. Rypinski, formerly with Brndes and Federal-Brndes, is now manager of the radio department of Westinghouse at 150 Broadway, New York City.

Irving K. Fearn, formerly sales manager of The Ken-Rad Corporation, has joined the French Battery Company as assistant to the president.

H. L. Williams, formerly with Silver-Marshall, Inc., is now advertising manager of the Rola Company, Oakland, Calif., and Cleveland, Ohio.

Fred O. Lange, former Director of Safety, Ohio State Industrial Commission, recently assumed his duties as director of personnel at the Crosley Radio Corporation's plant.

Organization of the legal division of the Federal Radio Commission was completed for the first time

## In the Tube Field

Ernest Kauer, president of CeCo, commenting on their development of an a.c. r.f. pentode says in refuting the claims of the RMA Engineering division: "To deny that CeCo's development is an advance in the radio art is as futile as was the attempt of automobile manufacturers who tried to delay the use of four-wheel brakes or balloon tires."

The Apex division of U. S. Radio & Television Corporation has placed an exclusive contract for its tube supply with the National Union Radio Corporation, according to a recent announcement. This company recently announced a seven-tube set priced complete with tubes at \$101.00.

Competitive lines in the radio tube field are being drawn in 1930 for the sharpest contest in the history of the industry, according to P. Huffard, president of National Carbon. "The tube industry is now in a similar position to that of the automobile industry in earlier years. From a position in which a good portion of the annual production came from a number of scattered manufacturers, that industry has evolved to a stage where the bulk of the production comes from a very few concerns. This is exactly the stage at which, in our opinion, the radio tube industry will have arrived by the end of 1930. The handwriting is definitely on the wall and should not be disregarded.

"The tube market offers one of the greatest replacement markets available to industry. It is destined to grow from year to year."

since the creation of the Commission with the appointment recently of two assistants to the general counsel. They are Duke M. Patrick, of Indianapolis, and Ben S. Fisher of Marshfield, Oregon.

Fred W. Piper is now sales manager of the Howard Radio Company.

Keith Henney, for five years director of RADIO BROADCAST's laboratory, is now on the staff of *Electronics* in New York City.

H. W. KaDell, formerly of National Carbon Company's Research Laboratory in Cleveland, has been transferred to New York City. His new position is sales engineer in the Eveready-Raytheon Tube Division of the general sales department.

Dr. Lee DeForest has recently been appointed consulting editor of the new publication *Electronics*.

Jesse Butcher, formerly with Doubleday, Doran & Company, Inc., and the New York Times, is now director of press relations for the Columbia Broadcasting System in New York.

R. T. Pierson has been appointed executive representative in contacts with radio, automotive, and electrical specialty industries by the General Cable Corporation, New York.

Harry Sadenwater, formerly engineer in charge of broadcasting stations of the General Electric Company, has recently joined the RCA-Victor Company, Inc., at Camden, New Jersey, as chief field engineer.

Lewis M. Clement, formerly chief engineer of Kulster Radio Corporation, has resigned and has joined M. S. Ripinski in the radio engineering division of the Westinghouse Electric & Manufacturing Company, 150 Broadway, New York City.

Donald McNicol has been appointed editor of *Radio Engineering*, succeeding M. L. Muhleman. (Other news items on pages 352 and 353)

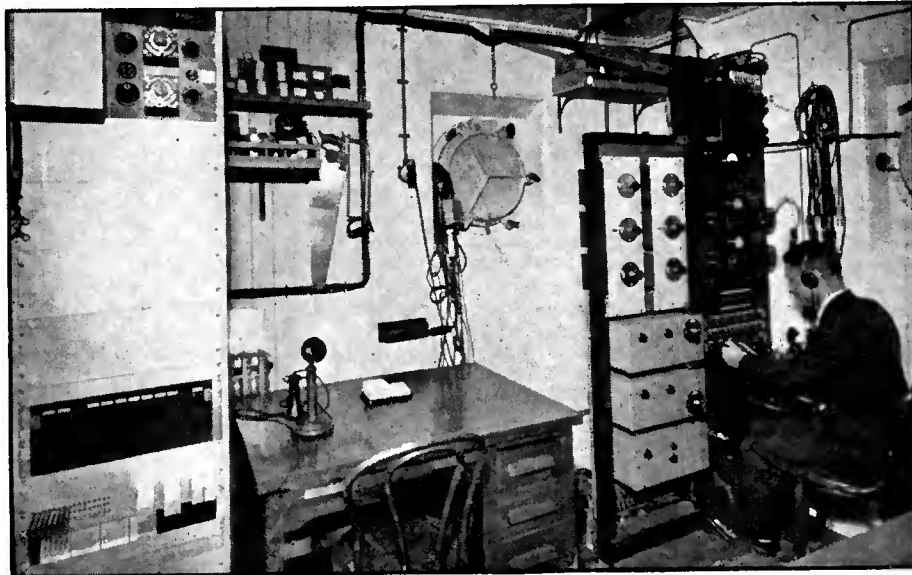

The inauguration of two-way ship-to-shore telephone service on the S. S. Leviathan makes it possible for any passenger to transact business or talk with friends by telephone while crossing the Atlantic. This picture shows the radio telephone equipment on the Leviathan. To the right is the receiving apparatus where voices from shore telephones are received by radio from the Deal (N. J.) station.





By the author of

**"Principles of Radio Communication"**

An independently written introduction to the subject of Radio

John H. Morecroft

**Elements of Radio Communication**

BY JOHN H. MORECROFT

"We can highly recommend 'Elements of Radio Communication' to those of our readers who want a book that will give them a strong, elementary grounding in radio and leave them with few questions to ask save those which may be born of a desire for more knowledge."

Boston Post Radio Section

**\$3.00**

**JOHN WILEY & SONS, Inc.**

440 Fourth Ave., New York

Please send me Morecroft's "Elements" for free examination. Within ten days after its receipt I will either return the book or send you \$3.00.

Name.....

Address.....

Firm..... RB 4-30

**Hi 30 The World's Premier Custom-Built RADIO**

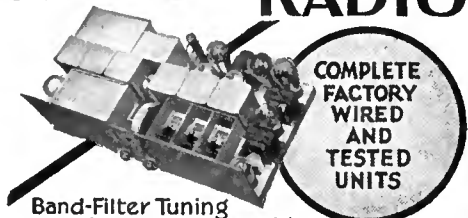

**COMPLETE FACTORY WIRED AND TESTED UNITS**

Band-Filter Tuning  
Screen-Grid Amplifier  
Six Tuned Circuits  
World-Wide Range

NO radio produced in mass can even approximate the skilled perfection of the new Custom-Built "HiQ-30." Here is the newest, most efficient model by Hammarlund—the climax of five years of unequalled custom designing and famed throughout the world for power, selectivity and tone. A great opportunity for custom-set builders. Choice of magnificent cabinets and speakers.

A. C., D. C. and Battery Models. List, \$139.50 to \$1,175 complete, less tubes.

Mail Coupon for 48-page "HiQ-30" Manual



HAMMARLUND-ROBERTS, Inc.  
424-138 W. 33rd St., N. Y.  
Enclose 25c (stamps or coin) for "HiQ-30" Manual. RB 4

Name..... Address.....

(Continued from page 351)

**News of the Manufacturers**

The Irving Trust Company of New York, as receivers for Sonora Products Company and Sonora Phonograph Company, was authorized by Federal Judge Coxe in New York early in February to continue the business of the companies for two months. If it is considered necessary, the receivers may apply for an extension. The purpose of the extension is to give the companies and creditors an opportunity to reorganize and to free the properties of the receivership.

Early in February, the receivership proceedings instituted against the DeForest Radio Company were dismissed by Chancellor V. M. Lewis of the Chancery Court at Paterson, N. J. Officials of the DeForest Company presented to the Court evidence of the solvent condition of the Company and statements which showed that during the 18 months of operation under the present officers a net profit of \$626,421.98 was realized. January 1930 showed a 24 per cent. increase over the previous month's business according to President Garside.

Soon after March 1, the Edison Lamp Works of General Electric, located at Harrison, N. J., will be transferred to Nela Park, Cleveland. The Harrison plant will be entirely taken over with the removal of the Lamp Works by the RCA Radiotron Company.

The Allwood, N. J., plant of Earl Radio has been completely shut down and is no longer operating.

The plant, good will, and assets of the Balkeit Radio Company, North Chicago, has been purchased by R. I. Mendles and R. L. Eglaston. They will operate under the name of the Balkeit Sales Company. Offices will be maintained at North Chicago and at 205 West Wacker Drive, Chicago. Mr. Mendles is president and Mr. Eglaston vice president and general manager of the new company. Mr. Eglaston was at one time general manager of the Karas Electric Company in Chicago.

Buckingham Radio Corporation, 410 West Superior St., Chicago, on December 27th was placed in the hands of a receiver in bankruptcy. Certain reorganization plans are under consideration but no definite announcement has yet been made.

**Matters Legal**

DeForest has filed suit against Pilot Radio & Tube Corporation, Brooklyn, manufacturers of radio parts, knockdown kits, and assembled radio receivers. DeForest seeks an injunction to restrain Pilot from an alleged infringement of DeForest patents Nos. 1507016 and 1507017 covering the use of regeneration in a radio receiving circuit. Says President Garside of DeForest: "There is a mistaken idea at large that the regenerative patent is public property, instead of the private and presumably valuable property of the DeForest Company."

Maine has a law primarily affecting the use of radiating receivers. It follows in full:

**CHAPTER 215**

An Act to Render Unlawful All Disturbances to the Reception of Radio Waves Used for Radiotelephony.

Sec. 1. It shall be unlawful to use within the state of Maine any radio receiving set which radiates radio waves, between two hundred and five hundred and fifty meters wavelength, thereby causing interference with the reception of any other radio receiving set unless said radiating set shall be rebuilt or re-designed to prevent said radiation.

Sec. 2. Whoever knowingly, maliciously, or wantonly by any means unreasonably disturbs the reception of radio waves used for radiotelephony, between two hundred and five hundred and fifty meters wavelength, shall be punished by a fine of not less than ten dollars and not more than fifty dollars to be recovered by complaint in any municipal or police court or before any trial justice.—Approved April 16, 1927.

A large chart tabulating the Federal Radio Act and amendments has been prepared by Nathan B. Williams and copies can be secured from him at the Insurance Building, Washington, D. C.

The Radio Corporation has requested that the Federal Trade Commission dismiss the complaint against it which charged that certain patent licenses granted by RCA to makers of receiving sets violated certain sections of the Clayton Act and the Federal Trade Commission Act. The license agreement was charged to require licensees to equip their sets initially only with RCA tubes. The Trade Commission has taken no action and no date has been set for a hearing.

**Remote Control Patents**

At the present time considerable activity is being shown by the radio industry in the direction of obtaining patents on automatic and remote-tuning devices. Most of the inventions in this field have been made recently, and, therefore, a large percentage of the patent applications have not yet been acted upon. For the same reason, several manufacturers do not feel sure of their present positions and hesitate in making any statement on the subject for publication. However, because of the extreme interest in these developments a partial list of important manufacturers and their patent holdings has been compiled.

Name of Company	Remarks
All-American Mohawk Corp.	No patents filed
American Bosch Magneto Corp.	Do not own any patent
The Amrad Corporation	Do not own any patent
Atwater Kent Mfg. Co.	Patents applied for but not yet allowed
Carter Radio Co.	No patents issued yet. Several applications on file for some time
Colonial Radio Corp.	No patents at present time
Crosley Radio Corp.	Do not own or control any patents
Colin B. Kennedy Corp.	Do not own or control any patents
Kolster Radio Corp.	Patent No. 1552919; other patent applications including our basic case still pending in the Patent Office
Philadelphia Storage Battery Co.	No patents issued
Stronberg-Carlson Telephone Mfg. Co.	Patent Nos. 1655160; 1738262
Union Carbide & Carbon Research Labs., Inc.	Own no patents
Zenith Radio Corp.	Patent Nos. 1581145 (reissued 17002); 1638734; 1591417; 1704754; 1695919.

**C.B.S. Negotiating for KMOX**

The Columbia Broadcasting System is negotiating for the purchase of control of KMOX, St. Louis. In addition to ownership of its key station, WABC, it has acquired control of WBBM, Chicago, and WCCO, Minneapolis. The purchase of WOR seems to be foreshadowed by its incorporation as a separate entity.

## Recently Issued Patents

**Electron-Emitting Material and Method of Making The Same.** William Benjamin Gero, Bloomfield, N. J., assignor to Westinghouse Lamp Company. Filed June 29, 1928. No. 1,731,244.

**Base for Radio Tubes.** Clair J. Terrill, Dayton, Ohio, assignor to the Kurz-Kasch Company, Dayton, Ohio. Filed November 8, 1926. No. 1,731,832.

**Apparatus for Recording and Reproducing Sound.** Richard S. Arthur, New York, N. Y. Filed February 5, 1926. No. 1,732,036.

**Sound-Regenerating Device.** Vehri D. Pack and Joseph M. S. King, Salt Lake City, Utah, assignors to Utah Radio Products Company, Inc. Filed July 29, 1926. No. 1,735,873.

**Cross Screen Picture Receiving System.** Richard Howland Rauger, Newark, N. J., assignor to Radio Corporation of America. Filed January 9, 1928. No. 1,736,219.

**Means for and Method of Volume Control of Transmission.** George Crisson, East Orange, N. J., assignor to American Telephone and Telegraph Co. Filed Sept. 12, 1924. No. 1,737,830.

**Arrangement to Protect Capacitive Loud Speakers Against Puncture.** Manfred von Ardenne, Berlin, Germany. Filed April 28, 1928, and in Germany April 28, 1927. No. 1,737,872.

**Diaphragm Especially for Sound Receiving and Radiating Apparatus.** Heinrich Hecht, Kiel, Germany, assignor to Signal Gesellschaft mit beschränkter Haftung, a firm of Kiel, Germany. Filed February 9, 1925, and in Germany February 20, 1924. No. 1,737,883.

**Volume-Control System.** Lee G. Bostwick, East Orange, N. J., assignor to American Telephone and Telegraph Co. Filed March 6, 1925. No. 1,737,992.

**Means For and Method of Volume Control of Transmission.** Estill I. Green, East Orange, N. J., assignor to American Telephone and Telegraph Co. Filed August 5, 1926. No. 1,738,000.

**Television.** Herbert E. Ives, Montclair, N. J., assignor to Bell Telephone Laboratories, Inc., New York, N. Y. Filed May 20, 1926. No. 1,738,007.

**Piezo-Electric Crystal Oscillator.** Alfred Crossley, Washington, D. C., assignor to Wired Radio, Inc., New York, N. Y. Filed May 28, 1926. No. 1,738,041.

**Method and Apparatus for Remotely Controlling Radio Receiving Systems.** Winfred T. Powell, Rochester, N. Y., assignor to The Stromberg-Carlson Telephone Manufacturing Co., Rochester, N. Y. Filed October 15, 1925.

## Tube Makers Defend The Pentode

(Continued from page 350)

for coöperation on circuit problems. This is a service we owe set manufacturers, and we are eager to render all the aid we can.

The Pentode represents a definite advance in radio. It cancels the necessity of multi-tube receivers. It permits building more simplicity into radio manufacture; makes simpler and less costly receiver operation and maintenance. It should reduce manufacturing and material costs, and costs to the radio public.

Tests in our own laboratory and in laboratories owned by others, show that the CeCo a.c. pentode performs up to all the claims we make for it. The results of these tests also prove that the pentode tube does make possible four-tube sets, or three-tube sets not counting the rectifier, and that these sets will operate as satisfactorily as the many-tube sets of to-day. In our own laboratory, we are doing considerable research work to develop new receivers for commercial use outside of radio. I venture to predict that in less than a dozen years the tube division of the radio industry will be the dominant factor in radio's march of progress.

The CeCo Manufacturing Company has had some criticism by set manufacturers because of what they call a premature announcement of the pentode tube, but the manufacturer who does not like change is in for an uncomfortable time. Nothing can stop the changes that are coming.

The progressive manufacturer is in for one of the most profitable and interesting periods in our history. It is sometimes remarked that business needs to be stabilized. When a man says that he means that he would like to get his business fixed so that he would not have to worry any more. If he wants stability in business, let him go to the Oriental countries; they have had their business stabilized over

Single-Side-Band Carrier System. Estill I. Green, East Orange, N. J., assignor to American Telephone and Telegraph Company. Filed September 20, 1926. No. 1,744,044.

**Combined Recorder and Reproducer.** Arthur C. Keller, New York, N. Y., assignor to Bell Telephone Laboratories, Inc., New York, N. Y. Filed February 10, 1928. No. 1,744,047.

**Modulation System.** Robert L. Davis, Wilkesburg, Pa., assignor to Westinghouse Electric and Manufacturing Co., Filed August 6, 1925. No. 1,744,214.

**Audio- and High-Frequency Amplifying Tube.** Siegmund Loewe, Berlin, Germany, assignor to Radio Corporation of America. Filed October 18, 1925, and in Germany November 13, 1924. No. 1,744,653.

**Frequency Changer for Short Waves.** Mendel Osnos and Richard Kummich, Berlin, Germany, assignor to Gesellschaft für Drahtlose Telegraphie m.b.H., Berlin, Germany. Filed August 14, 1925, and in Germany Aug. 16, 1924. No. 1,744,668.

**Radio Transmitting System.** Georg von Arco, Berlin, Germany, assignor to Gesellschaft für Drahtlose Telegraphie m.b.H., Hallesches, Berlin, Germany. Filed November 23, 1925, and in Germany December 6, 1924. No. 1,744,711.

## Patent Suits

M. C. Hopkins, Acoustic device, filed Sept. 26, 1929, D.C., E.D., N.Y., Doc. 4450, Lektophone Corp. v. Colonial Radio Corp. No. 1,271,529.

L. A. Hazeltine, Method and means for neutralizing capacity coupling in audions, filed July 18, 1929, D.C., E.D., N.Y., Doc. 4323, Hazeltine Corp. v. National Carbon Co., Inc., et al. Same, filed July 31, 1929, D.C. E.D. N.Y., Doc. 4362, Hazeltine Corp. v. A. I. Namm & Son, Inc., Doc. 4363, Hazeltine Corp. v. Abraham & Strauss, Inc. Same, filed Aug. 3, 1929, D.C. E.D. N.Y., Doc. 4369, Hazeltine Corp. v. E. A. Wildermuth. Same, filed Aug. 9, 1929, D.C. E.D. N.Y., Doc. 4371, Hazeltine Corp. v. Brooklyn Radio Service Corp., Doc. 4372, Hazeltine Corp. v. Colonial Radio Sales Co., Inc. No. 1,533,588.

L. A. Hazeltine, Wave Signaling system, filed Aug. 13, 1929, D.C. E.D. N.Y., Doc. 4387, Hazeltine Corp. v. E. A. Wildermuth. No. 1,648,808.

A. J. Weiss, Electrical Condenser, filed Sept. 30, 1929, D.C., E.D. N.Y., Doc. 4452, Dubilier Condenser Corp. v. Aerovox Wireless Corp.

there for hundreds of years, but where are they to-day? Some people say ours will be a great country when it is finished. When this country is finished, its period of greatness will be over, for at that time the life will have gone out of it.

We may be thankful it will never be finished. Our industry will always need and want new ideas.

## Good News for Servicemen

After considerable study and discussion, a plan has at last been worked out whereby the Radio Service Managers Association is enabled to conduct examinations of out-of-town servicemen by mail.

The plan as worked out for the out-of-town serviceman, requires that he first supply the R.S.M.A. with the name of his employer, or if unemployed, with the name of a notary public in his town to whom the examination may be mailed. Having done this the applicant must then arrange to take his examination in the presence of this party and have him fill out a form of affidavit to certify that all of the requirements and conditions under which the examination was sent have been complied with.

All papers must be mailed to the office of the R.S.M.A. for correction along with the original questions and must be accompanied by an application for membership and dues. Upon correction the applicant will be advised as to his mark and in all cases where a satisfactory mark has been made, certification cards will be issued. Those failing to make a satisfactory grade will be obliged to wait a period of thirty days before another examination may be taken.

Any serviceman wishing to secure an R.S.M.A. certification should address the Radio Service Managers Association at 324 West 42nd Street, New York City, designating the party to whom the examination papers are to be sent.

To  
Think of

Transformers

is to  
Think of

**THORDARSON**

TRANSFORMER  
SPECIALISTS  
Since 1895 . . .

Microphone Transformers

Line to Tube, Tube to Line,

Line to Line . . . . .

Mixing Transformers

● Coupling Reactors ●

Filter Chokes . . . . .

Audio Transformers ●

Impedance Matching

Transformers ● Power

Compacts . . . . .

Speaker Coupling Trans-

formers . . . . .

Complete Amplifiers . .

**THORDARSON  
ELECTRIC ● ●  
MANUFACTURING  
COMPANY ● ●**

**Huron, Kingsbury and  
Larrabee Streets . . .  
Chicago, Illinois, U. S. A.**

# IN THE RADIO MARKETPLACE

News, Useful Data, and Information on the Offerings of the Manufacturer

## Majestic Receivers

GRIGSBY-GRUNOW COMPANY: The Majestic line of radio receivers now includes the following models: Model 90 at \$95.00 less tubes or \$116.50 completely equipped with Majestic tubes; Model 91 at \$116.00 and \$137.50 with tubes;



Model 92 and 93 at \$146.00 and \$167.00 with tubes; Model 102 radio-phonograph at \$184.00 and \$205.50 with tubes, and Model 103 at \$203.50 and \$225.00 with tubes.

## Cornell Paper Condensers

CORNELL ELECTRIC MANUFACTURING COMPANY: This company manufactures a complete line of small and large by-pass condensers for use in radio receivers. Based on 0.0005-inch paper linen the Cornell specifications are as follows:

**Thickness:** Capacitor tissue must caliper as close to specified thickness as possible. In no case should individual readings vary more than 5 per cent. over or under the thickness specified in the order.

**Porosity:** Capacitor tissue must not measure less than 105 seconds in air resistance.

**Uniformity:** The tissue is to be free from wrinkles, cockles, creases, slugs, and to be practically free from pinholes.

**Width of tissue:** The width of the tissue must be within  $\frac{1}{4}$  inches of the specified width up to a maximum width of 4 inches. Between 4 inches and 8 inches the variation shall not be greater than  $\frac{1}{8}$  inch plus or minus.

**Alkalinity:** No more than one gram of paper shall require more than 0.30 milligrams of sulphuric acid for complete neutralization.

**Acidity:** The water extract of one gram of paper shall not require more than 0.10 milligrams of sodium hydroxide for complete neutralization.

## SAF-3 Mixer

SIMPLIMUS, INC.: The SAF-3 Mixer is designed for use in a theater "sound-movie" installation and its function is to control the quality of

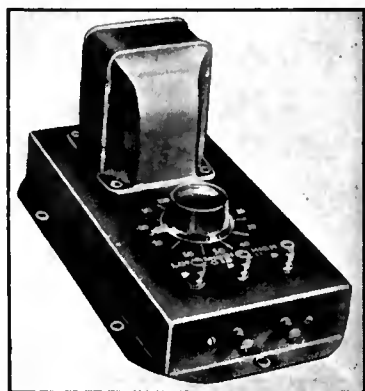

reproduction. The unit is connected between the pick-up unit and the amplifier. On the instrument are three switches marked "Low Register," "Middle Register," and "High Register," and a knob marked "Compensator." The instrument functions to eliminate to an extent determined by the setting of the compensator the band of frequencies to which the switch is turned, i.e., if the switch is placed on "Low Register" the low frequencies are suppressed. If connected to the "High Register" position the high frequencies are suppressed. In this way the operator can reduce that part of the audio-frequency range which normally receives too much amplification due either to poorly designed sound equipment or to poor theater acoustics. The instrument is manufactured to the specifications of Simplimus by the S A F Electrical Engineering Company.

## Antenna Equipment

M. M. FLERON AND SON, INC.: Lightning arrestors, complete antenna kits, light-socket antennas, ground clamps, loud speaker extension cords, insulators, lead-in strip, porcelain lead-in bushings, and other similar items are manufactured by this company.

## Supreme Tube Tester

SUPREME INSTRUMENTS COMPANY: The Model 50 Tube Tester is designed especially for use in testing laboratories, high-grade service laboratories, and by large dealers and distributors. The unit is self contained, drawing all its power from the 60-cycle, 110-volt a.c. line. To compensate line-voltage variations the unit contains a constant-voltage transformer manufactured under a license from the Ward Leonard Electric Company. The instrument will test all types of tubes, a.c. or d.c., three-element or four-element. An indication of  $\mu$  and Gm are obtained by a direct-reading on the dial. By pressing buttons the tube can be tested for gas and emission. The unit sells at a dealer's net



price of \$98.50. A much simpler tube checker, the Model 17, is designed to give simple but effective tests on tubes. The net price is \$19.50. The Model 10 Ohmmeter may be used to determine the value of resistors and is also useful in checking apparatus and tracing circuits. Net price: \$17.50.

## New Photo-Electric Cell

JENKINS TELEVISION CORPORATION: An extremely sensitive hydride type photo-electric cell for television work has been developed. It is now in production and available to the public through the sales department of the De Forest Radio Company.

## Precision Resistance Amplifier

INTERNATIONAL RESISTANCE COMPANY: Joseph Morgan, of the Engineering Department of this company, has developed a resistance-coupled amplifier which gives uniform frequency response within 1 db from 0 cycles up to 20,000 cycles per second. Another type of amplifier has been designed with a gain of approximately 55 db, a power output of about 4.5 watts, and uniform response over the frequency range of 30 to 10,000 cycles. Complete engineering bulletins describing these amplifiers can be obtained from the company.

## New Bosch Models

AMERICAN BOSCH MAGNETO CORP.: The two newest Bosch consoles using the Bosch screen-grid chassis and electrodynamic loud speaker are the model 11 listing at \$198.50 and the Model 16 listing at the same price.

## New Silver Receivers

SILVER MARSHALL, INC.: Six models of Silver Radio are now available. The three newest models are the Model 60B Lowboy, \$145.00, less tubes, or \$169.50 complete; Model 75B Concert Grand, \$158.00 less tubes, or \$182.50

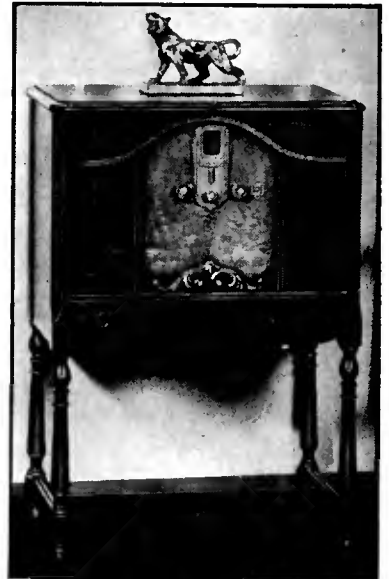

complete; and Model 95B Highboy, \$145.00 less tubes, or \$169.50 complete. These latest models use a screen-grid circuit with a screen-grid detector. Two of the four tuned circuits are placed ahead of the first tube so as to prevent cross-talk. The chassis is cadmium plated.

## New CeCo Tube

CECO MANUFACTURING COMPANY: The new CeCo 227 replacing the old type N-27 has the following features:

Two mica spacing members, the upper one much larger than usual.

A grid built around two supporting bars instead of the usual single bar.

Short cathode.

Shortened distance from glass stem to electrode.

Longer glass stem.

The larger upper mica separator holds both cathode and grid in positions concentric to the plate and yet when the tube heats it permits expansion without strain to cause warping. The double supported grid helps to maintain tube uniformity. The tube is not of the quick-heating type, although the new tube does reach an operating temperature quicker than did the old tube. In this connection CeCo engineers stated, "Actually the cathode reaches its operating temperature in less time than did the cathode of the N-27. CeCo will release a quick-heating tube when and only when a way is found to combine quick heating with satisfactory operating life."

## Turntable Equipment

ELECTRICAL RESEARCH PRODUCTS, INC.: A number of broadcasting stations have purchased turntable equipment from this company to permit the use of special or ordinary phono-



graph records for broadcast programs. The turntables are available in either single or double units operating at either 33½ or 78 r.p.m. At the present time the equipment is in use at approximately twenty broadcasting stations. The equipment is not sold outright but is loaned to the station under a three-year license agreement which includes complete servicing by ERPI. The following stations have this equipment at the present time. In the following list

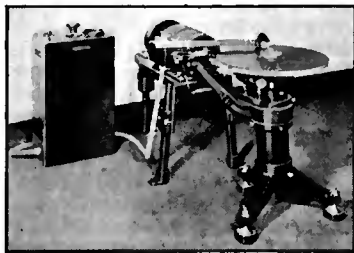

"Double 33½" means two turntables operating at 33½ r.p.m. "Double 78" means two turntables operating at 78 r.p.m.

WTMJ	Double 33½	Double 78
KMOX	Double 33½	
WOC	Double 33½	Double 78
WOAA	Single 33	
WCAD	Single 33	Double 78
WSM	Double 33	Double 78
KPHC	Single 33	Double 78
KFUM	Single 33	Double 78
KLZ	Double 33	Double 78
WBT	Single 33	
WTAM	Double 33	Double 78
KFEL	Single 33	
KFH	Double 33	Double 78
KJBS	Double 33	Double 78
KWCR		Double 78
WHK	Double 33½	
KHQ	Double 33½	
WMT		Double 78
WLBW	Double 33½	Double 78
WKDH	Double 33½	Double 78

## Electrical Meters

FERRANTI, INC.: This company announces a new line of microammeters, milliammeters, and voltmeters for use in measuring alternating currents at all frequencies from 20 to 6000 cycles. The instruments use dry rectifiers in conjunction with d.c. indicating meters. There are two types available, one having a resistance of 667 ohms per volt and drawing 1.5 mA. at full-scale deflection, and the other type having a resistance of 133 ohms per volt and drawing 7.5 mA. for full-scale deflection. The microammeter is made in only one size with a maximum reading of 750 microamperes. The milliammeters are available in ranges from 1.5 up to 500 mA., ammeters in ranges from 1 to 5 amperes, and voltmeters in ranges from 1 to 250 volts. Practically all of the instruments are priced at \$35.00. The instruments can replace the vacuum-tube voltmeter in many measurements and are ideal for determining the frequency performance of audio-frequency amplifying systems.

## Gulbransen Model 9950

GULBRANSEN COMPANY: The Model 9950 is a nine-tube receiver using screen-grid tubes, power detector, and push-pull audio-frequency amplification. The list price is \$99.50.

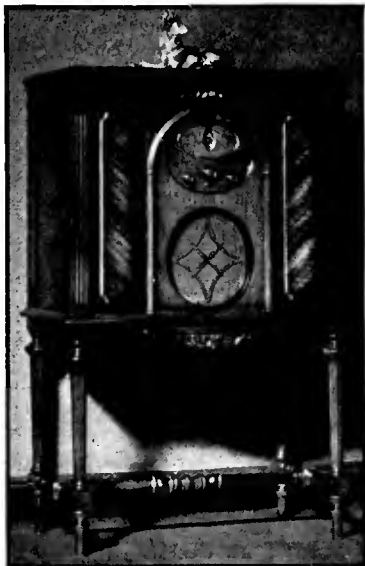

## Wire-Wound Resistors

INTERNATIONAL RESISTANCE COMPANY: This company announces wire-wound, non-inductive resistors, wound to an accuracy of approximately one-half of one per cent. Each unit consists of an Isolantite tube with prominent fins to form a series of miniature bobbins which hold the winding. The winding is arranged in opposite directions in adjacent bobbins for the non-inductive effect. The tubing and winding are treated with bakelite varnish, while the end caps are molded rather than soldered to the ends, providing the best possible contact with the winding. A special grade of resistance wire is employed, with improved insulation so as to withstand much higher voltages without breakdown than the wire heretofore employed in layer-wound resistors. The Durham wire-wound units are available in resistance values from 500 ohms to several megohms.

## Oxford Loud Speakers

OXFORD RADIO CORPORATION: Several new models have been added to this company's line of electrodynamic loud speakers. Some of the loud speakers are equipped with a universal coupling transformer arranged with tapped connections so that the loud speakers may be used with various types of tubes. Transformers to meet special conditions are furnished on request.

## Transmitting Condensers

NATIONAL COMPANY, INC.: The Type TNU National transmitting condensers have ratings of 5000 and 7500 volts. The end plates are cast aluminum and all rotor and stator plates have rounded and polished edges. By special arrangement with the Radio Corporation of

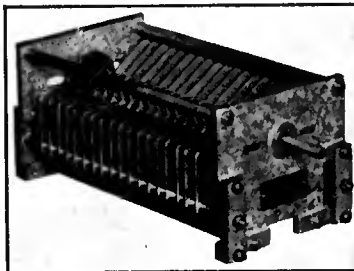

America, Micalex insulation is employed. Type R-39 insulation, a special development of the Radio Frequency Laboratories, can be supplied if desired in place of Micalex. The condensers are of variable capacities from 0.0005 to 0.0005 mfd. Prices range from \$47.50 down to \$41.00.

## Booklets and Catalogs

FERRANTI, INC.: The new Ferranti catalog gives complete details of various types of Ferranti power amplifiers, audio-frequency transformers, pocket test sets, d.c. tube testers, fixed condensers, wire-wound resistors, d.c. voltmeters, ammeters, and all types of a.c. meters.

INTERNATIONAL RESISTANCE COMPANY: A booklet entitled "Fixed Resistor Replacement Problems" available to any interested persons gives some data on the importance of fixed resistor replacement. The a.c. receiver caused a very marked increase in the number of resistors used in a set and proper consideration in their replacement is of obvious importance.

DEFORREST RADIO COMPANY: A comprehensive catalog covering the extensive line of DeForest transmitting and power-rectifying audions had just been issued by the De Forest Radio Company, Passaic, N. J. The De Forest line now includes thirteen transmitting and rectifying audions, for use as oscillators, rectifiers, radio- and audio-frequency amplifiers, and modulators. These tubes range in power from 15 to 5000 watts. Among the types cataloged are mercury-vapor rectifiers, screen-grid transmitters, and water-cooled tubes, thereby covering every standard function in transmitting and auditorium amplification. Aside from the standard broadcast reception audions, the DeForest products also include the DeForest neon lamp, and photo-electric cells manufactured to exact specifications. The catalog is available to anyone on request.

## Home "Talkie" Outfit

STEVENS MANUFACTURING CORPORATION: This company has designed a small outfit incorporating an electric turntable, electric pick-up, a.f. amplifier, and electrodynamic loud speaker together with the necessary power supply for the entire assembly. The equipment, which has been designed for use in connection with home-movie apparatus, is now in production and available to the public.

## Loftin-White Kit

ELECTRAD, INC.: A complete kit for the construction of a Loftin-White amplifier is available from Electrad. The kit designated as A-245 contains all parts except tubes. The amplifier utilizes one 224-type screen-grid tube, one 245-type power tube, and one 280-type rectifier. The amplifier is designed primarily for use in

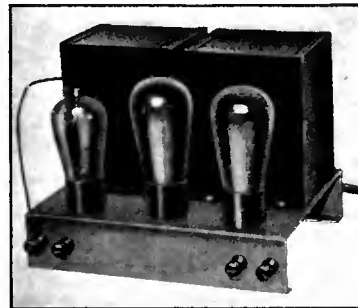

connection with electric pick-up units but with the addition of a conventional coupling device it can be connected to various radio tuners. The list price is \$35.00 less tubes.

## Radiola Price Reductions

RCA-VICTOR COMPANY, INC.: The Radiola Division of the RCA-Victor Company, Inc., has announced a change in the list price of three of its models. Radiola 47, a screen-grid radio-phonograph combination, has been reduced from \$275.00 to \$195.00; Radiola 64, a superheterodyne receiver, has been reduced from \$550.00 to \$193.50; and Radiola 66, console superheterodyne receiver, has been reduced from \$225.00 to \$175.00, the new prices, which are quoted less tubes became effective as of January 30, 1930.

## New Variable Condensers

ROCHESTER TOOL AND GAUGE CORPORATION: Condensers manufactured by this company are housed in complete shielding with tubing adjustment screws for the compensators. A separate compensator is associated with each unit of the gang and gives a variation of approximately 40 mmfd. The minimum capacity of the 0.0005-mfd. condenser is 30 mmfd. and 24 mmfd. for the 0.00035-mfd size. The contour of the rotor is such that 40 per cent. gives 1 kc. separation and the other 60 per cent. a 2-meter separation. The shaft is 1/8" in diameter. Flexible contact leads are supplied. The plates are hard sheet aluminum 0.32 inch thick.

## Fada Model 40

F. A. D. ANDREA, INC.: The Model 40 uses tuned impedance coupling with 224-type screen-grid tubes followed by a 227-type power detector, a 227-type a.f. amplifier, and two 245-type power tubes. Features of the receiver are automatic station finder and indicator, special tone adjuster, and a Fada super-electrodynamic loud speaker. The Model 40 has been tested and approved by the Underwriters Laboratories of the National Board of Fire Insurance Laboratories.





### Measuring Resistance

ONE OF THE simplest methods of measuring resistances is by the use of a d.c. voltmeter connected in series with the resistor to be measured and across a known d.c. voltage. The circuit is shown on this sheet.

The procedure is to measure the d.c. voltage first with the voltmeter. The resistor to be measured is then connected in series with the meter and the reading of the meter noted. With these data the value of the resistor may be obtained from the formula—

$$R_o = \frac{E_o - E_r}{E_r} \times R_m$$

where  $R_o$  is the resistance in ohms;

$E_r$  is the voltage read on the voltmeter with the resistance connected in series with the voltmeter;

$E_o$  is the voltage of the source, i.e., that voltage indicated by the meter when it is connected directly across A-B;

$R_m$  is the resistance of the meter.

Therefore, the only data needed to measure resistances by this method is the resistance of the voltmeter. This information may be marked on the meter or, if not, it can be obtained from the manufacturer. In the following paragraphs are a few examples worked out by this method.

Example: A 250-volt meter with a resistance of 1000 ohms per volt is to be used to measure the

value of an unknown resistor. The voltmeter is connected directly across three B batteries and the potential is found to be 140 volts. The unknown resistor is then connected in series with the meter and the meter reads 25 volts. What is the value in ohms of the resistance?

Since the voltmeter has a resistance of 1000 ohms per volt, the total resistance,  $R_m$ , is 1000 times 250 or 250,000 ohms.  $E_o$  as measured is 140 volts.  $E_r$  is 25 volts. Therefore—

$$R_o = \frac{140 - 25}{25} \times 250,000$$

$R_o = 1,150,000$  ohms as the value of the unknown resistor.

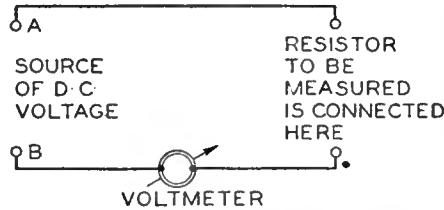

### Three Types of Distortion

SEVERAL DIFFERENT types of distortion can be produced in the power tube. Distortion may result from (a) volume distortion, (b) frequency distortion, and (c) harmonic distortion.

**Volume distortion:** The ratio between the output obtained from a tube and the a.c. input voltage to its grid should be constant up to the point where the tube begins to overload. If the ratio between output voltage and input voltage increases as the input voltage increases the strong signals are amplified more than weak signals; if, conversely, the ratio decreases as the input voltage is increased, strong signals are amplified less than weak signals. In power tubes this type of distortion is slight, the power output per volt input squared being constant up to the point at which the tube overloads.

**Frequency distortion:** A tube and its associated circuits should give uniform amplification to all frequencies over the audio-frequency band it is desired to transmit. If the amplification varies with different input frequencies certain notes are amplified more or less than others. Over the audio-frequency band little distortion of this type is

produced by the tube itself, although frequency distortion may be introduced by the apparatus associated with the power tube, such as the input or output transformer and loud speaker.

**Harmonic distortion:** If a pure sine wave at some frequency is applied to the grid of a tube and in the output of the tube the same and other frequencies appear, then harmonic distortion is occurring. All power amplifiers produce a certain amount of this type of distortion, its extent depending upon the characteristics of the tube itself and the circuits out of and into which it works. The amount of second-harmonic distortion is used as a basis for rating the maximum undistorted output from a tube. If an ordinary three-element tube is working into a load resistance equal to twice its own plate resistance, the second-harmonic current is about 5 per cent, at a point just before the tube begins to overload. This amount of distortion is considered small enough to be negligible. A tube may, of course, generate other frequencies besides the second harmonic and, in fact, when a tube is somewhat overloaded it produces large amounts of second-, third-, and fifth-harmonic distortion.

### Detection Characteristics

DETECTION characteristics showing the relation between the d.c. plate current and r.f. input to a detector are very useful in determining the best point at which to operate a tube as a detector. Such a group of curves are shown on this sheet, being taken from an article "Detection at High Signal Voltages" by Stuart Ballantine published in the *Proceedings of the Institute of Radio Engineers*.

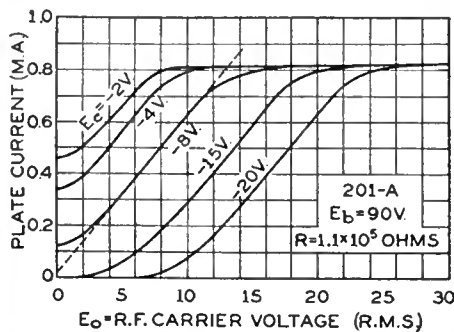

The curves on this sheet are for a 201A-type tube operated with a resistance load in the plate circuit from a battery potential of 90 volts. Five curves are shown for grid biases from -2 to -20 volts. These curves were made by measuring the plate current as the r.f. input voltage was gradually increased from 0 up to 30 volts. The plate currents obtained with the various input voltages were then plotted and the series of curves shown on this sheet was obtained.

Minimum distortion will be obtained when the r.m.s. value of the carrier input is such as to bring the operating point of the tube at about the center of the straight portions of these curves. When this is done a linear characteristic is obtained and minimum distortion results. For example, the best operating point on the curve corresponding to the bias of minus 8 volts is with a carrier input of about 7 or 8 volts r.m.s. If the carrier input is greater or less than this figure some distortion will result especially at high values of modulation. Since many sets have the volume control in the r.f. amplifier so that the r.f. input to the detector varies depending upon the volume control setting an effect such as described above would take place. This can be prevented, however, by obtaining the bias of the tube from the plate current so that as the r.f. input changes the detector will tend always to operate on the proper characteristic.

## BOOK REVIEWS

**HOW TO PASS THE U. S. GOVERNMENT RADIO LICENSE EXAMINATIONS** by Rudolph L. Duncan and Charles E. Drew. Published by John Wiley and Sons, Inc., N. Y. C., 1929. Paper covers, 9-3/4" by 6-5/8", 169 pages, illustrated. Price: \$2.00.

This book is not offered as a complete textbook on radio operating or radio theory; its chief purpose is to aid the more or less experienced radio man who contemplates taking the government radio license examination. The authors point out in the foreword: "There are many experienced radio men who fail to pass the government examination because they are not familiar with commercial apparatus and commercial operating procedure. Then there are others who are more or less handicapped because they lack expression; they know the subject from the practical viewpoint but they are unable to put their knowledge into words. The real purpose of this book is to show how radio questions and examinations should be answered."

The text and illustrations of this volume consist chiefly of 259 typical questions (with correct answers) such as might be found on U. S. Government radio examinations. These questions include all phases or radio operating and theory with which the commercial operator is required to be familiar, including; commercial and broadcast transmitters, radio receiving apparatus, motors and generators, storage batteries and auxiliary apparatus, radio laws and regulations, etc. In addition to questions and answers the book contains a chapter giving regulations governing the issuance of radio operators' licenses and an Appendix which contains important radio formulas, frequency vs wavelength tables, standard radio symbols, the "Q" signals, the International Morse Code, and other important data.

**RADIO TRAFFIC MANUAL AND OPERATING REGULATIONS** by Rudolph L. Duncan and Charles E. Drew. Published by John Wiley and Sons, Inc., New York City, 1929. Paper covers, 9" by 6", 187 pages, illustrated. Price: \$2.00.

This volume by the authors of *Radio Telegraphy and Telephony* and *How to Pass the U. S. Government Radio License Examinations* will be helpful to amateurs, Army and Navy radio operators, and to others who wish to enter the field of radio operating. It describes fully government and commercial traffic rules and regulations which govern the manner in which radio communications shall be handled and gives other instructions which should be followed by the operator as closely as conditions permit. It is not only useful to the beginner who is anxious to learn commercial technique but is also valuable as a reference book on the commercial operator's operating table. The text includes the U. S. Radio Act of 1912, The Ship Act of July 3, 1912, and a complete index.

## WIRING DIAGRAMS

are now available to supplement the wiring diagrams in Riders "Trouble Shooter's Manual." Supplementary Package No. 1 contains 115 wiring diagrams of radio receivers manufactured during 1929-1930. Many of the latest screen grid receivers are included. These schematics are black on white, 8 x 11 inches, punched for standard three-hole binding.

115 wiring diagrams for \$2.50

RADIO TREATISE CO.

1440 Broadway

New York City

## CHARACTERISTICS OF TELEVISION SIGNALS

(Continued from page 319)

is only necessary to employ synchronous motors of the same speed for rotating both mechanisms. Temporarily, while the television audience consists mainly of amateurs interested in results with the minimum expenditure, this method is ideal. However, as the service areas of visual broadcasting stations are increased it will become necessary to employ more intricate means of synchronizing.

A synchronizing tone, let us say 720 cycles (which is the scanning frequency of a 48-line picture at 15 pictures per second), is transmitted to the receiving point.

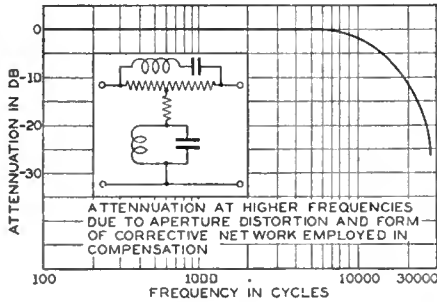

Fig. 11

This may be supplied by a photo-electric cell operated by a light ray passing through the scanning apertures or by a small alternator operated from the same motor as the scanning mechanism. This 720-cycle signal may be transmitted to the receiving point as a modulation of a second carrier, or as a modulation of a 30-kc. wave which in turn modulates the same carrier as the picture signal, or it may be intermixed with the picture signal in the correct proportion. In the first two cases it would be necessary to employ two receivers or a special receiving system of the "double-modulation" type. The third case merely involves a filter circuit arranged so as to remove the 720-cycle component from the last stage of the picture amplifier. The synchronizing signal is employed separately and applied to a 720-cycle motor operating the scanning mechanism. In order to reduce the power required in the synchronizing motor, two sources of power are employed. A simple d.c. or a.c. motor supplies enough power to neutralize the friction and windage losses and starts the scanning mechanism in rotation. The 720-

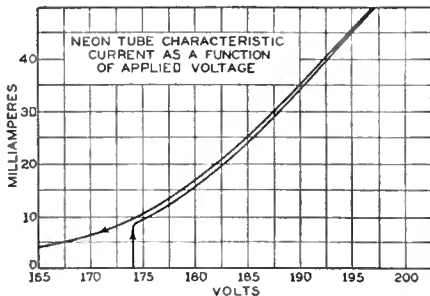

Fig. 12

cycle synchronous motor serves merely to maintain rotation and synchronous speed. In starting up, the power input to the first motor is raised so as to pass through the required speed, and then the motion is retarded until interlocking occurs.

### Errors in Adjustment

Certain aspects of the image indicate errors in adjustment which may be readily corrected if they are borne in mind. Thus an inverted picture tells us that the scan-

(Continued on page 358)

# CASH IN On a New Demand

Every city and town offers opportunities for the sale and installation of sound equipment, and local radio dealers are the logical men to cash in on this demand. Wright-De Coster Reproducers and horns are meeting with tremendous success wherever installed—for either indoor or outdoor use.

## WRIGHT-DE COSTER REPRODUCER

There is a most efficient type of equipment for every purpose ranging from a tremendous battery for outdoor or arena use to single units for theatrical use and smaller sizes for home radio.

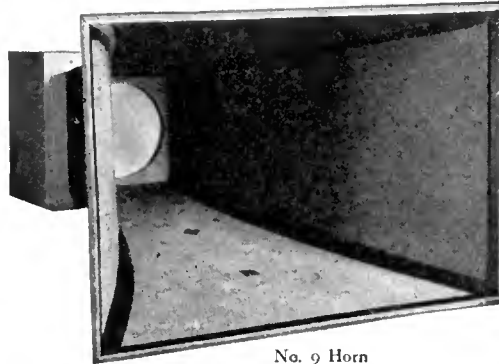

No. 9 Horn



Write for Complete Information  
and Name of Nearest Sales Office

**Wright-De Coster, Inc.** 2213 University Ave., St. Paul, Minn.

Export Dept.—M. Simons & Son, 220 Broadway, New York City  
Cable Address, Simontricc, New York

## A Radio Parts Guide

### THE NEW YAXLEY

#### Catalog



Send for it today for complete listings of Radio Convenience Outlets, Connector Plugs, Rheostats, Fixed and Grid Resistances, Jacks, Jack Switches, Phone Plugs, etc.

**YAXLEY MFG. CO.**

Dept. B, 1528W Adams St., Chicago, Ill.



## C. R. I.

Trains men for all  
branches of radio work.

Including:

COMMERCIAL RADIO  
RADIO SERVICE

RADIO BROADCAST NAVIGATION  
RADIO MATHEMATICS LABORATORY  
VITAPHONE-MOVIE-TONE

Dormitory—Laboratory—Workshop

Literature on Request

**COMMERCIAL  
RADIO INSTITUTE**  
38 W. BIDDLE ST. FOUNDED 1920 BALTIMORE, MD.



## Fulco RADIO COVERS

"FULCO" covers are used by those dealers who realize the importance of making deliveries in perfect condition — without scratches or mars. For they know that complaints mean dissatisfied customers and loss of business.

"FULCO" covers are a real service feature that helps sales and holds trade. Substantially constructed, heavily padded, box-shaped, providing perfect protection. Give us the dimensions of radios handled and let us quote special prices on your individual needs. Write our nearest house.

**Fulton Bag & Cotton Mills**

Manufacturers Since 1870  
ATLANTA · NEW ORLEANS · DALLAS · ST. LOUIS  
MINNEAPOLIS · BROOKLYN · KAN. CITY · KAN

ON AND OFF  
IN A JIFFY

### Calculating Detector Output

IN "LABORATORY SHEET" No. 339 is given the "transrectification" diagram of a 201A-type tube operated at a battery potential of 90 volts with a 110,000-ohm load in its plate circuit. This diagram shows the relation between d.c. plate current and r.f. input voltage with various values of C bias. The method of obtaining the curve and a brief explanation of what it means will be found on the same sheet. In the following notes we explain how it is possible from this simple diagram to determine the audio-frequency output voltage from a detector with a given r.f. input signal.

To explain how this is done let us take for example the center curve corresponding to a grid bias of minus 8 volts. This particular curve then shows the plate current obtained with various r.f. voltages applied to the input. With zero r.f. input the plate current is approximately 0.12 milliamperes, and, as the r.f. input is increased, the plate current gradually rises and then flattens out. It reaches a maximum of 0.8 milliamperes. Let us assume that an r.f. input of 7 volts modulated at say 43 per cent. is applied to the grid. What will be the a.f. voltage appearing across the load resistance? The steady plate current obtained with an r.f. signal of 7 volts

will be 0.46 milliamperes. If the r.f. is modulated 43 per cent. it means that the r.f. voltage varies about its mean value, 7 volts, by 43 per cent. Therefore, it reaches maximum values of  $7 + (7 \times 0.43)$  or 10 volts and minimum values of  $7 - (7 \times 0.43)$  or 4 volts. The plate current corresponding to 10 volts input is 0.63 milliamperes and the plate current corresponding to 4 volts is 0.27. The a.c. plate current will therefore be one having an absolute peak of 0.63 milliamperes and a minimum of 0.27, the difference between these two being equal to twice the peak value of the a.c. current. This difference is 0.36 and dividing by 2 we get 0.18 as the peak value of the audio-frequency current in the plate circuit. Dividing this peak value of 0.18 by the square root of 2 to get r.m.s. values we have 0.128 as the effective a.c. plate current. This current in amperes multiplied by the load resistance gives the a.c. voltage. In this case it is  $0.000128 \times 110,000$  ohms which gives 14.1 as the audio-frequency voltage. This value of audio-frequency output obtained by calculation agrees very closely with the measured value. This method of calculating detector output is therefore very effective and comparatively simple.

(Continued from page 357)

ning disc is placed backwards on the shaft or that the shaft is rotating in the wrong direction. The cure is obvious. Because of the 180-degree phase shift encountered in each vacuum tube stage, it is necessary to employ an even number of stages in the amplifier, otherwise the picture will be "negative" with the light and dark portions transposed. Hence, a negative picture indicates that we are employing the wrong number of stages or that a stage is inoperative.

If the picture travels across the field of vision from left to right, the receiver mechanism is leading that at the transmitter; if from right to left it is lagging. In either case the motor speed should be adjusted accordingly.

The picture may be seen "out of frame" either vertically or horizontally. If this occurs in the vertical direction, the trouble may be rectified by starting and stopping the receiving motor until the motors start off with the two scanning spirals in their correct relation.

Should the picture be out of frame horizontally, the neon lamp may be moved laterally or the disc may be shifted on the shaft. This may be due to phase displacement in the supply voltage causing one motor to lag behind or lead the other. This factor is variable and it is desirable to construct the mechanism so that the adjustment may be readily made. This may be done by having the neon lamp mounted in a fashion allowing lateral movement at will or by arranging the stator of the synchronous motor so that it may be rotated during operation.

It is impossible to give a comprehensive résumé of television because of limited space and because of the rapid strides being made. It is hoped that these few words may assist in visualizing the basic problems encountered.

### AIRCRAFT RADIO DEVELOPMENT

(Continued from page 332)

3. Topography of country causes shift of zone.

The reed type or visual beacon is more practical, and has several inherent advantages. The principle is similar to the aural type just described, with the exception that two different modulated frequencies are transmitted from the two loops. These vary between 50 and 120 cycles per second, and are usually chosen about 20 cycles apart; frequencies of 65 and 85 cycles are most frequently used as the modulating frequencies.

The receiver output is connected to two electrically driven white-tipped reeds, held in a shock-proof box on the control dash. These reeds are tuned to the two transmitted modulation frequencies. When the plane is on its course, the amplitude of each two reeds is approximately the same, but as soon as the pilot deviates, one or the other reed has greater amplitude, and the pilot gives his ship right or left rudder depending upon which direction he is off course until the two reeds have the same amplitude again.

Either of these systems is good up to about 135 miles under ordinary conditions and still greater distances could be covered with higher frequencies.

#### Radio Altimeters

A barometric type of altimeter is quite unsatisfactory for land flying. The pilot is interested in his height above ground rather than above sea level. Two general types of radio altimeters which indicate height above ground are being perfected, one of which is the reflected-wave type, and the

(Continued on page 359)

### Reflection of Sound

THE INTENSITY of the sound we hear at any point in a room when listening to the output of a loud speaker is a function of the intensity of the direct sound ray, the reflected ray, standing waves, and the amount of reverberation. The diagram on this sheet together with the following notes gives a simple idea of the effect of the direct and reflected rays.

The diagram shows a cone loud speaker placed a short distance in front of a wall. During operation of the loud speaker sound waves will be radiated in all directions and if the listener is located at point A the sound he hears will be due to the direct ray and the reflected ray—the reflected ray being the one which leaves the loud speaker, strikes the wall and is then reflected into the room. The amount of energy reflected from the wall of course depends on the material composing the wall—ordinary hard walls are good reflectors and a major portion of the sound is reflected. If the walls are draped or are made of some acoustic material the amount of sound reflected is much less.

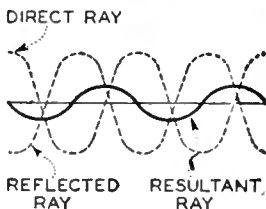
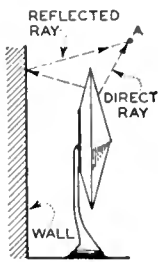

The phase relation between the two waves at the point where the listener is located determines the intensity of the sound (neglecting reverberation), and if the two waves are exactly opposite in phase very little sound will be heard. On the other hand, some sound will always be audible because reflections are also taking place from all other parts of the room. The effects of this type of reflections are prevented somewhat by the use of a baffle (although this is not the most important reason for the use of a baffle). Reflection is most noticeable at low frequencies.

The curves on this sheet indicate graphically the effects which occur due to the direct and reflected rays. If the two waves are essentially 180 degrees out of phase the resultant, shown by the heavy line, is very small which means that the intensity of the sound is very low. However, reflection is not always a thing to be avoided. For example, it occurs in an auditorium and often adds atmosphere to the music being played.

### Grid Current in Tubes

IN MAKING measurements, especially on power tubes, it is frequently found that a small amount of current flows in the grid circuit even though the grid has a negative bias. Offhand this seems very serious for we usually operate a tube at negative potential to prevent the flow of grid current. Actually, however, the current flowing in the grid circuit when the grid is negatively biased may not affect the operation of the tube seriously for the following reason.

In the first place, it should be understood that we operate the grid of a tube at negative voltages so as to make the input impedance of the tube very high; in fact, the input circuit of an ordinary amplifier may have an impedance of a million ohms at audio frequencies. Since the impedance is very high practically no power need be expended in the grid circuit to develop comparatively large voltages. If, on the other hand, the input impedance is low the power required to develop the same voltage will be larger, and, as a result, the tube is a less efficient amplifier.

Now if the a.c. voltage across the grid circuit is E then the impedance of the input of the tube will be equal to the voltage E divided by I, the a.c. current in the circuit. That is—

$$\text{Input impedance} = \frac{E_{ac}}{I_{ac}}$$

So if I is zero then the impedance is infinitely large while if I is large then the input impedance is low. But it must be remembered that I is an alternating current. The d.c. current flowing in the grid circuit may be any value at all without affecting the a.c. input impedance of the tube. And now we reach the important point: it is not the value of the grid current as read on a d.c. meter that is important but rather it is to what extent this current varies with the applied a.c. input signal. In most cases the grid current which flows with negative voltage on the grid is a "gas" current, and about the same amount of current flows at all negative values of grid voltage. Therefore, even when an a.c. signal is applied to the grid so as to make the grid voltage vary about the operating point, the current in the grid circuit is constant (at least practically so) and the a.c. current produced is very small. This makes the denominator of the equation very small and therefore the input impedance very high. In summary, it may be said that grid current at negative grid voltages does not affect the input impedance of a tube unless this current varies considerably with grid voltage.

other the capacity type. Experiments have been carried on by Dr. E. F. W. Alexander-son on the reflected-wave type and this instrument will be described first.

The phase of the returning wave is different from the phase of the transmitted wave due to time lag. If the distance is varied by an amount which is a fraction of a wavelength this variation will manifest itself in a variation of the phase of the returning wave relative to the phase of the transmitted wave. If the distance is varied by an amount of several wavelengths, then the phase of the returning wave will go through a corresponding number of cyclic changes in phase. Thus, if we have an instrument for ascertaining the phase of the returning wave and are able to count the number of cyclic changes, we are thereby able to make absolute measurements of the height above ground.

An oscillator will vibrate at its natural period only when the restoring forces which are contained in the oscillator itself are the only ones that exist. When these restoring forces are acted upon by outside forces, these forces either add or subtract from the inherent restoring forces. It will swing to a higher frequency when the restoring forces are in phase and swing to a lower frequency when the restoring forces are out of phase. The changes may be aural, graphic, or visual. In actual tests on a 95-meter wave, a graphic chart was made up to 4000 feet and the waves balanced out every 155 feet. Graphic altitude logs may also be used for surveying.

### Beat Frequency Method

Another system for direct-reading indicating instruments would be by the beat-frequency method. Two antennas are used; for example, one of 10 meters and the other of 11 meters. The maxima of the beat frequency will occur at 25 meters altitude, 75 meters, and again at 125 meters. This could be used with indicating lights for landing in a fog or similar conditions. The strongest or 25 meter (80 feet) elevation could light a red light, the next or 75 meter (240 feet) height would light a yellow light, and the third or 125 meter (400 feet) elevation could light a green light. If the oscillators were set for a 2 per cent. difference instead of a 10 per cent. difference, the scale would be 5 times as large and the strongest maxima would be noted at 125 meters (400 feet), the next at 375 meters (1200 feet), and the third at 625 meters (2000 feet). By having an automatic arrangement for shifting the difference between the two oscillators, it is possible to measure the height of the plane above ground with sufficient accuracy for landing purposes.

Another type of radio altimeter is the one being developed by Ross Gunn of the Bellevue Naval Laboratory. This altimeter works upon the principle that metal plates or wires, sensitive to small changes in electrical capacity, function in accordance with the principle that a perceptible change in capacity takes place when two electrical conductors come within close proximity of a third conductor. Also the capacity of a condenser varies in inverse proportion to the distance between the plates. This altimeter does not rely upon the "echo" signal as in other types. Its sensitivity increases as the plane approaches the ground. It is reasonably accurate up to 150 to 200 feet altitude above ground. As little as 5 feet will record accurately. This type can be made to read direct. A 1000-kc. wave is transmitted from an antenna or plate and reacts with the other plate upon its approach to a conductor like the earth. Under actual tests, this altimeter was within 5 per cent. accurate up to 150 feet. There are no unusual adjustments. Two handicaps of this

(Continued on page 360)

# TYPE 360 TEST OSCILLATOR

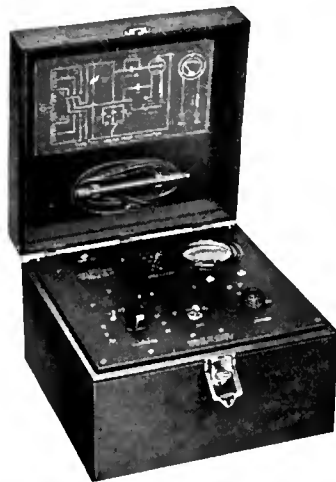

One of the new test oscillators for the radio service laboratory is now ready. It will deliver a modulated radio-frequency voltage at any point in the broadcast band (500 to 1500 kilocycles) and at 175 and 180 kilocycles. The tuning control is calibrated with an accuracy of 2 per cent.

The Type 360 Test Oscillator is intended to be used for neutralizing, gang- ing, and tuning of the radio-frequency stages in a receiver, and it is fitted with an output voltmeter for indicating the best adjustment. This voltmeter is of the copper-oxide rectifier type, and by means of a switch it may be connected across a 4000-ohm load or across the dynamic speaker of the receiver when making tests.

Price \$110.00

## GENERAL RADIO COMPANY

30 State Street

Cambridge, Massachusetts

### Wanted:

Representative in each town for new easy selling proposition to home-makers. Generous commissions, bonus and sales helps supplied. Especially attractive offer to club or civic workers. Apply

Box R. B. % The American Home  
Garden City, N. Y.

### ROBERT S. KRUSE

Consultant and Technical Writer

103 Meadowbrook Road, West Hartford, Conn.  
Telephone Hartford 45327

### Service Men— Set Builders— Dealers

We have a very interesting proposition for you about the

## BROWNING-DRAKE screen-grid RADIO

Browning-Drakes always appealed to technical radio men. More Browning-Drake kits were sold than any other make. Send for this new proposition.

**Browning-Drake Corporation**  
224 Calvary Street Waltham, Mass.

## Extra Money! For Service Men

Extra  
Enjoyment  
for  
Construction  
Fans



### RETURN COUPON FOR FREE BOOKLET!

You know dozens of people who cannot (or will not) buy a 1930 receiver, but who will spend a reasonable amount to secure 1930 tone quality. This free booklet tells about the profit possibilities of modernizing old sets with new Pilot transformers.

**PILOT RADIO  
& TUBE CORP.**  
323 BERRY STREET, BROOKLYN, N. Y.

**PILOT RADIO AND TUBE CORP.**  
323 Berry Street, Brooklyn, N. Y.

Send me without obligation "A 1930 Voice For Old Sets"

NAME.....  
ADDRESS.....  
CITY.....STATE.....



Speech Power and Its Measurement

IN CONNECTION with a paper entitled "Speech Power and Its Measurement" by L. J. Sivian, published in October, 1929, *Bell System Technical Journal*, curves and data are given on two devices useful in many ways. Curves and circuits of the two units—a volume indicator and an impulse meter—appear on "Laboratory Information Sheet" No. 344 and the following are some notes regarding their use.

The volume indicator meter has been widely used for controlling amplification in radio broadcasting, in phonograph and film recording of speech and music, and for rapid measurement and control of speech levels. Essentially the volume indicator is a three-element vacuum-tube voltmeter with a rapid-action d.c. galvanometer in the plate circuit. The tube is operated on a part of its characteristic such that the rectified plate current is proportional to the square of the voltage input. The meter combined with the electrical circuit has a dynamic characteristic as shown by the curve on "Sheet" No. 344, which gives the maximum deflection as a function

of the duration of the a.c. input voltage. For inputs lasting more than about 0.18 seconds the maximum deflection remains the same, and, since the average syllable duration in speech is of the order of 0.2 seconds, it follows that the maximum deflection is approximately proportional to the mean power.

The impulse meter is essentially a peak-reading voltmeter and the circuit is designed so as to cause the plate current to reach its ultimate value with an input of as short a duration as possible. The time required for the galvanometer to reach its maximum deflection is determined by the dynamic characteristic of the meter and its associated plate circuit as well as by the time constant of the condenser-charging circuit connected to the grid of the tube. The curve, therefore, shows the rate at which the potential on the blocking condenser builds up and by reference to the curve it will be noted that the plate current reaches 80 per cent. of its ultimate value with an a.c. input of only approximately 0.015 seconds.

(Continued from page 359)

type are "background capacity" and tendency to "drift."

Conclusion

Radio is doing much toward aiding aërial navigation and making aviation a safe commercial possibility. Radio is doing much toward making aviation fool-proof and making it possible to fly in inclement weather with safety. Meteorological reports, radio beacon service, and direct communication are doing much toward making aviation a dependable institution. Radio control of airport landing lights will make night flying safer. As planes become larger and space and payload become less important, more dependable and larger apparatus can be used to advantage. All sciences are interdependent, and thus commercial aviation is benefited directly by radio development. Aviation, with the cooperation of radio, will give us the safest, most rapid, and cheapest transportation ever known to mankind.

MEASURING PERCENTAGE MODULATION

(Continued from page 335)

cycles. In Fig. 1A the percentage of modulation is 18 per cent.; in Fig. 4B, 41 per cent., and in Fig. 4c the transmitter is seriously overloaded, since part of the cycle is completely suppressed. It is easy to see that the modulation no longer has a sinusoidal shape. The remark may be made that, even without the rotating mirror, the beginning of overloading can be seen directly upon the stripped picture on the tube. The unmodulated part of the carrier wave appears with great brilliance, since it affects the cathode ray twice as long as the ends of the stripe. The width of this bright part of the middle of the stripe becomes less and less with increasing degrees of modulation and shrinks to a lighted point in the stripe with more than 100 per cent. With a little practice the percentage modulation can be evaluated direct from the stripe.

An oscillograph of a broadcast transmitter is shown in Fig. 4d. This picture was taken with the arrangement shown in the heading illustration, i.e., with a h.f. amplifier in front of the tube. These pictures, which are of considerable value for the control of the transmission, show that nearly 100 per cent. modulation is present. With a vacuum-tube voltmeter and an indicating instrument for the determination of the degree of excitation, momentary overloads can hardly be seen due to the inertia of the instruments used. The instantaneous and easily readable cathode-ray oscillograph is, therefore, to be preferred for a continuous watch in the transmitting station.

The WGY-KGO Problem

In a report to the Commission, Martin Rice states that, since WGY has been operating simultaneously with KGO, 62 per cent. of reports from listeners in New York, Ohio, Indiana, Illinois, and Iowa complain of poor reception, while only 8 per cent. from that territory raised objections before the dual assignment went into effect. In Iowa, Nebraska, Colorado, Wyoming, Idaho, Utah, Nevada, Arizona, and Texas, 72 per cent. complain of reception quality, while prior to the present allocation, 88 per cent. in those states reported good quality. In California, where KGO used to receive no complaints, 32 per cent. of those writing in now report unsatisfactory reception.

Speech Power and Its Measurement

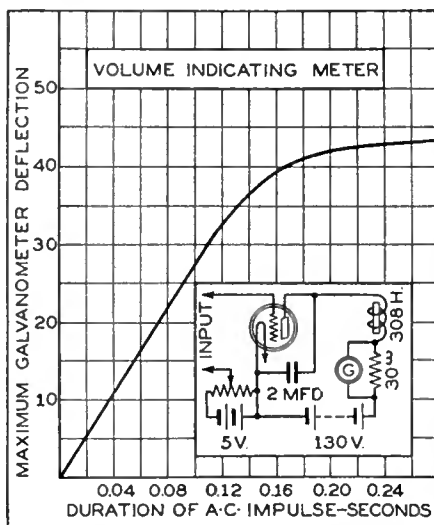
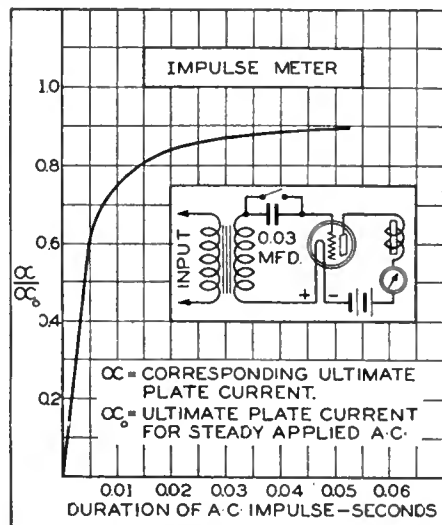

Regarding Grounds for A. C. Sets

IN THE INSTALLATION and use of a.c. radio receivers it is frequently found that more volume is obtained without any wire connected to the ground terminal than is obtained with a ground connection to the binding post. This effect has evidently given quite a few servicemen the impression that there was something wrong with the receiver. The fact is, however, that this quite common effect does not necessarily indicate that the receiver is defective.

The volume obtained from a receiver depends upon the ability of the antenna system to pick up signals and upon the gain of the radio receiver. Modern high-gain receivers have to be very carefully designed from the standpoint of shielding, filtering, and grounding to make them absolutely stable and if any one of these points is neglected the set will have some regeneration. On the other hand, if the set depends for some of its amplification on regeneration its performance will depend somewhat upon the conditions under which it is operated. Proper grounding is an important point in the prevention of regeneration and the lack of a

ground or a comparatively poor ground may cause an otherwise perfectly stable receiver to regenerate slightly.

This is the effect which is responsible for the peculiar operation of a.c. receivers with and without proper ground connections. With a proper ground the set has a gain approximating that which its makers intended it should have. If, however, no ground is used some regeneration will exist which will generally tend to increase the gain and, as a result, more volume is obtained. The disadvantage of not using a ground, however, is that this increased gain may only be obtained over a small part of the dial and at other points the set may tend to oscillate or the first tuned circuit may be thrown out of alignment so that the selectivity is impaired. For these reasons it is always advisable to operate a receiver with a ground if it is intended that it should have one. If for some reason the receiver must be operated without a ground it is worth while to try reversing the plug in the light socket in order to determine the position which gives the most satisfactory operation.

# 4<sup>th</sup> RMA Trade Show ATLANTIC CITY

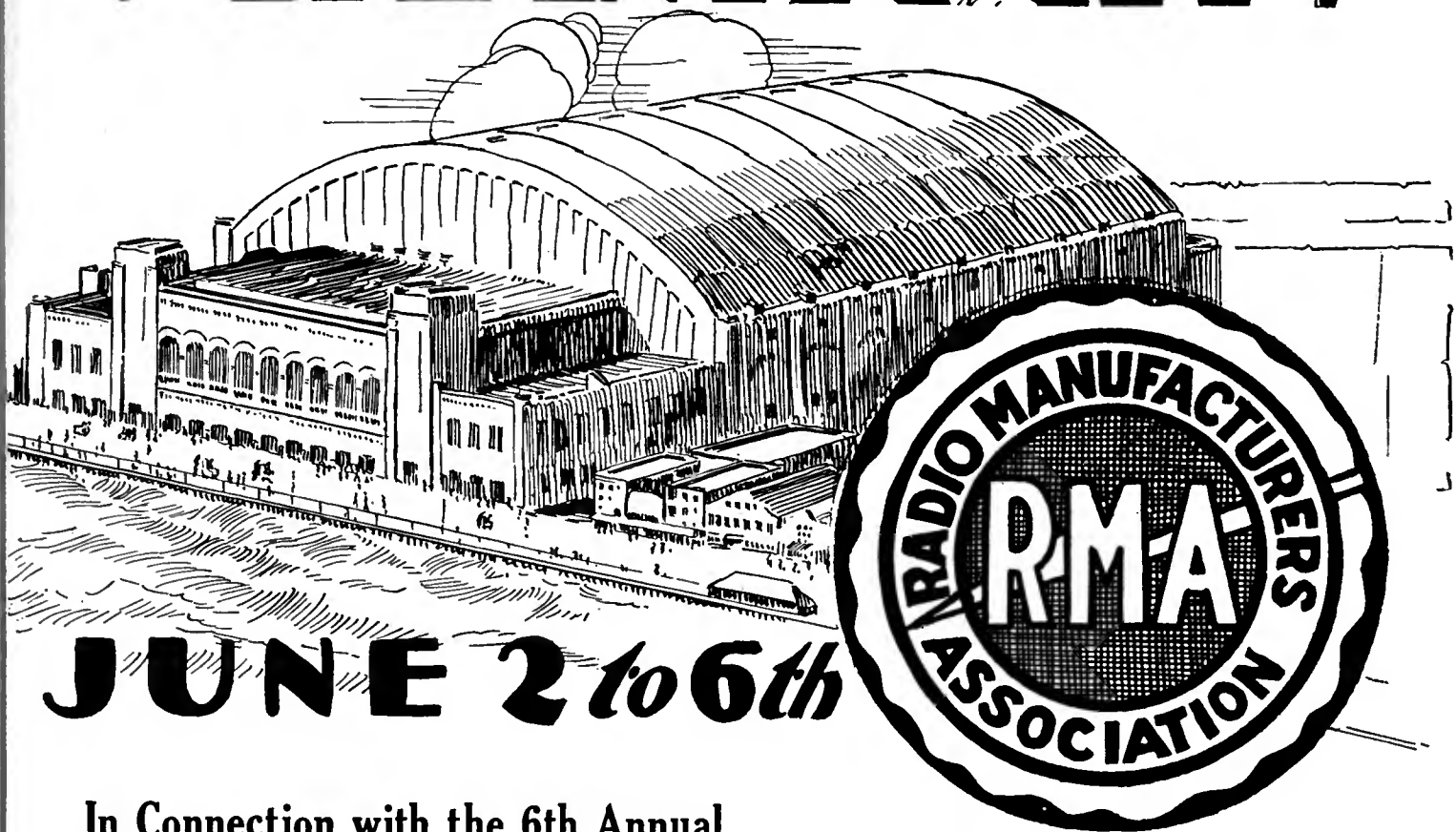

**JUNE 2 to 6<sup>th</sup>**

**In Connection with the 6th Annual  
R. M. A. Convention and the Federated Radio Trade Assn. Convention**

The fourth annual R.M.A. trade show will be held this June in Atlantic City, the playground of America, the country's pre-eminent convention city. It will be the largest trade show in the history of the radio industry, twice as large as last year's Chicago show.

Atlantic City offers more hotels, better accommodations, more to see, hear and do—this is the one trade show you cannot afford to miss.

The Atlantic City Auditorium, facing the boardwalk and cooled by the breezes of the Atlantic Ocean, is the largest convention hall in the country. All exhibition booths and demonstration rooms will be under one roof, on one floor, making it easy to get a comprehensive view of the entire trade show.

The June trade show marks the beginning of radio's new year. The most responsible manufacturers exhibit and demonstrate their latest models and accessories on this occasion. It behooves everyone connected with the radio industry to visit the trade show this year, which will be the most interesting and important radio gathering ever convened.

Hotel reservations should be made through the Atlantic City Convention Bureau, Atlantic City, New Jersey. Invitation credentials for the trade show will be mailed to the trade about May 1st.

*Reduced round trip rates on all railroads.*

**Radio Manufacturers' Association Trade Show, Room 1904, Times Bldg., New York**  
*Under Direction of U. J. Herrmann and G. Clayton Irwin, Jr.*

→  
**FIRST MINUTE**

Let your customer hold a watch on any set equipped with Arcturus Tubes. Snap the switch and check the starting time...the program is there in 7 seconds!

# THIS 3-MINUTE DEMONSTRATION

## PROVES ARCTURUS SUPERIORITY TO ANY TUBE BUYER



←  
**SECOND MINUTE**

Let your customer listen to the clear, pure tone that is characteristic of Arcturus Tubes. There's no annoying hum, no trace of outside noises, to mar the beauty of any program.



**T**HE self-evident superiority of Arcturus Blue Tubes means increased sales and extra profits. If you have not checked Arcturus quality yourself, ask your jobber for a demonstration. *Proved performance, not sales talk, has made Arcturus the fastest growing tube in the radio industry today.*

ARCTURUS RADIO TUBE COMPANY  
Newark, N. J.

→  
**THIRD MINUTE**

Show your customer, on the meter, that Arcturus Tubes easily withstand exceptional overloads. This unusual stamina explains Arcturus' long life.



they're  
  
blue!

# ARCTURUS

Quick Acting  
**RADIO TUBES**

